



XT690系列

伺服驱动器用户手册

XT690 Series Servo Drive
User Manual



* 本手册仅适用于XT690****-1
系列下的驱动器产品：敬请注意！



 宁波兴泰科技有限公司
Ningbo Xingtai Technology Co., Ltd.

地址：宁波市五乡工业园鑫瑞路6号
Add: No. 6 Xinrui Rd, Wuxiang Industry Park, Ningbo, China
电话(Tel)：+86 574 8766 8082
传真(Fax)：+86 574 8735 2448
网址(website)：http://www.xtservo.com
邮箱(Email)：info@xtservo.com

XT690系列 伺服驱动器用户手册

XT690 Series Servo Drive User Manual

Preface

Thank you for purchasing the XT690 series servo drives which independent R&D and manufactured by NINGBO XINGTAI TECHNOLOGY CO.,LTD.

XT690 series servo drives is upgrade from XT500 series, specially developed for permanent magnet servo motor(PMSM). It can realize the high performance vector control of permanent magnet synchronous motor. This series drives optimize as per the dynamic characteristics of in the injection molding machine drive process, For example, injection molding speed, pressure maintain accuracy control, and Stability control when adapting working with injection molding machine controller. Perfectly realized servo pump control; Compared to traditional injection molding machine drive mode, Energy saving effect is remarkable. Also to meet the demand of universal servo function. At present it is high cost performance, good stability servo drive on the market. This series drives mainly applied in the industries of plastic molding, processing, pipe extrusion line, shoemaking, rubber, metal die casting, etc. Compared to XT500 series, this series drives further improved on Hydraulic control performance, faster responded on Pressure and speed, Smaller fluctuations of steady pressure.

This manual name is 《XT690 Servo Drive User Manual》, only for XT690****-**-1 series model drives.

This manual provides model selection, installation, parameter setting, debugging and fault diagnosis relevant points for attention and the instruction, Please read this manual carefully when you first time to use this series servo drives. Equipment supporting customer please send this manual with the equipment to the end user, And please keep for later use.



Notes

- ◆ The drawings in the manual are sometimes shown without covers or protective guards. Remember to install the covers or protective guards as specified first, and then perform operations in accordance with the instructions.
- ◆ The drawings in the manual are shown for description only and may not match the product you purchased.
- ◆ The instructions are subject to change, without notice, due to product upgrade, specification modification as well as efforts to increase the accuracy and convenience of the manual.
- ◆ Contact our agents or customer service center if you have problems during the use.
- ◆ Phone service: 0574-87668087, Email: info@xtservo.com

◆ This manual for XT690****-**-1 series model drives!
Other series products, please refer to the related manuals!

Introduction

1) Functions :

Compared with XT500, the XT690 series AC drive incorporates the following improvements:

Improvements	Description
◆ more stable of Pressure	Smaller pressure fluctuation, Especially in the high pressure low speed, the performance is obviously.
◆ Fater response of pressure and speed	Pressure and speed response increase significantly, can satisfy the requirement of hydraulic quick machine quick response.
◆ Improve the injection molding finished products consistency	Injection qualification rate of products was improved, especially evident in rapid injection molding products
◆ Wide voltage range design	320V~450V
◆ More sophisticated built-in brake unit	With the protection of short circuit braking resistance, brake loop overcurrent, brake pipe overload, brake pipe straight
◆ Long life service design	Bus capacitor configuration is higher, longer service life
◆ Fan drive circuit protection	When the fan is accidental short-circuit, fan drive circuit can provide effective protection
◆ The whole facility protectio function more perfect	All models realize output to ground short circuit protection, buffer relay(contactor) Pull in failure protection
◆ EMC Configuration scheme optimized	Could provide a complete set of solutions as per actual application requirements and certification requirements (optional of EMI filter, Common-mode suppressor, Zero phase reactor, Simple filter)

2) Product Checking

Upon unpacking, check:

- Whether the nameplate model and AC drive ratings are consistent with your order. The box contains the AC drive, certificate of conformity, user manual and warranty card.
- Whether the AC drive is damaged during transportation. If you find any omission or damage, contact Invoice or your supplier immediately.

3) First-time Use

For the users who use this product for the first time, read the manual carefully. If in doubt concerning some functions or performances, contact the technical support personnel of XINGTAI to ensure correct use.

4) Standard

Xt690 series servo drive complies with the following LVD and EMC directives and standards:

Directive	Directive Code	Standard
EMC Directive	2004/108/EC	EN 61800-3 EN 55011 EN 61000-6-2
LVD Directive	2006/95/EC 93/68/EEC	EN 61800-5-1

Remark: The XT690 series servo drive complies with the requirements of standard IEC/EN 61800-3 on the condition of correct installation and use by following the instructions 8.3.2 and 8.3.5.

Wiring Diagram

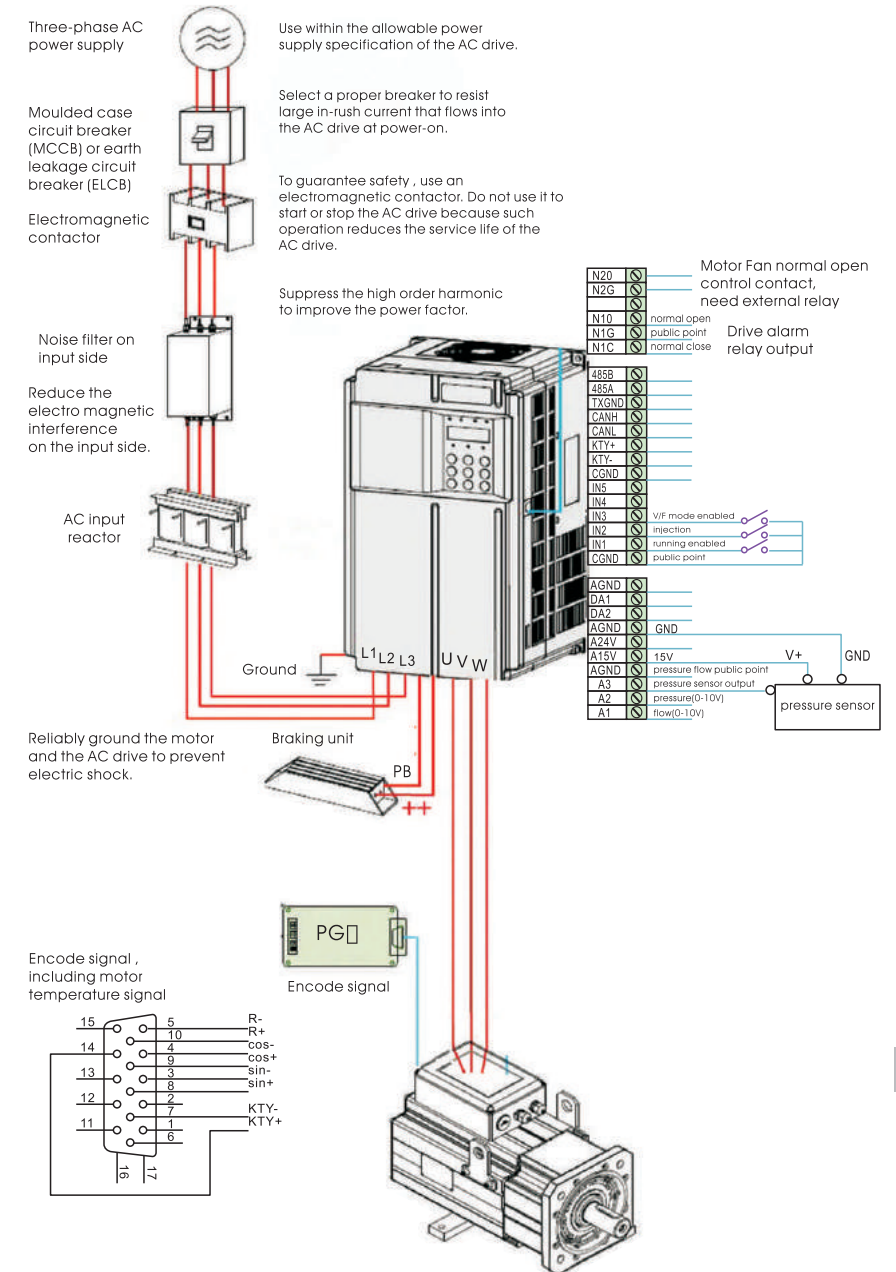

1

安全信息及注意事项

Safety Information and Precautions

Chapter 1. Safety Information and Precautions

In this manual, the notices are graded based on the degree of danger:

- **DANGER** indicates that failure to comply with the notice will result in severe personal injury or even death.
- **WARNING** indicates that failure to comply with the notice will result in personal injury

1.1 Safety Information and Precautions

1) Before installation

 DANGER
<ul style="list-style-type: none"> ◆ Do not use the equipment with damaged or missing components. Failure to comply will result in personal injury. !
<ul style="list-style-type: none"> ◆ Please use above class-B insulation of the motor, Or will get an electric shock risk!

2) During installation

 DANGER
<ul style="list-style-type: none"> ◆ Install the equipment on incombustible objects such as metal, and keep it away from combustible materials. Failure to comply may result in a fire!

 WARNING
<ul style="list-style-type: none"> ◆ Arrange the installation positions properly when two AC drives are laid in the same cabinet to ensure the cooling effect. (Refer to Chapter 3 Mechanical and Electrical Installation) ◆ Do not drop wire end or screw into the AC drive. Failure to comply will result in damage to the AC drive !

3) At wiring

DANGER

- ◆ Wiring must be performed only by qualified personnel under instructions described in this manual. Failure to comply may result in unexpected accidents!
- ◆ A circuit breaker must be used to isolate the power supply and the AC drive. Failure to comply may result in a fire!
- ◆ Ensure that the power supply is cut off before wiring. Failure to comply may result in electric shock!
- ◆ Tie the AC drive to ground properly by standard. Failure to comply may result in electric shock!

WARNING

- ◆ Never connect the power cables to the output terminals (U, V, W) of the AC drive. Pay attention to the marks of the wiring terminals and ensure correct wiring. Failure to comply will result in damage to the AC drive.
- ◆ Use wire sizes recommended in the manual. Failure to comply may result in accidents.
- ◆ Never connect the braking resistor between the DC bus terminals (+) and (-). Failure to comply may result in a fire.!

4) Before power-on

DANGER

- ◆ Check that the following requirements are met:
 - The voltage class of the power supply is consistent with the rated voltage class of the AC drive.
 - The input terminals (R, S, T) and output terminals (U, V, W) are properly connected.
 - No short-circuit exists in the peripheral circuit.
 - The wiring is secured.
 Failure to comply will result in damage to the AC drive
- ◆ Cover the AC drive properly before power-on to prevent electric shock.

WARNING

- ◆ Do not perform the voltage resistance test on any part of the AC drive because such test has been done in the factory. Failure to comply will result in accidents.
- ◆ All peripheral devices must be connected properly under the instructions described in this manual. Failure to comply will result in accidents.

5) After power-on

DANGER

- ◆ Do not open the AC drive's cover after power-on. Failure to comply may result in electric shock.
- ◆ Do not touch the AC drive's and around circuit by wet. Failure to comply may result in electric shock.
- ◆ Do not touch any I/O terminal of the AC drive. Failure to comply may result in electric shock.
- ◆ At the beginning of power on, the drives are auto safety check to external high-voltage electrical circuits. please do not touch the terminals (U, V, W) and motor terminals. Failure to comply may result in electric shock.

WARNING

- ◆ Do not touch the rotating part of the motor during the motor auto-tuning or running. Failure to comply will result in accidents.
- ◆ Do not change the default settings of the AC drive. Failure to comply will result in damage to the AC drive.

6) During operation

DANGER

- ◆ If choice re-start function. Do not close to machine. Failure to comply may result in personal injury.
- ◆ Do not touch the fan or the discharging resistor to check the temperature. Failure to comply will result in personal burnt.
- ◆ Signal detection must be performed only by qualified personnel during operation. Failure to comply will result in personal injury or damage to the AC drive.

WARNING

- ◆ Avoid objects falling into the AC drive when it is running. Failure to comply will result in damage to the AC drive.
- ◆ Do not start/stop the AC drive by turning the contactor ON/OFF. Failure to comply will result in damage to the AC drive.

7) During maintenance

DANGER

- ◆ Repair or maintenance of the AC drive may be performed only by qualified personnel. Failure to comply will result in personal injury or damage to the AC drive.
- ◆ Do not repair or maintain the AC drive at power-on. Failure to comply will result in electric shock.
- ◆ Repair or maintain the AC drive only the light of 'charge' off. Failure to comply will result in personal injury by the residual voltage in the capacitor.

1.2 General Precautions

1) Motor insulation test

Perform the insulation test when the motor is used for the first time, or when it is reused after being stored for a long time, or in a regular check-up, in order to prevent the poor insulation of motor windings from damaging the AC drive. The motor must be disconnected from the AC drive during the insulation test. A 500-V mega-Ohm meter is recommended for the test. The insulation resistance must not be less than 5 MΩ.

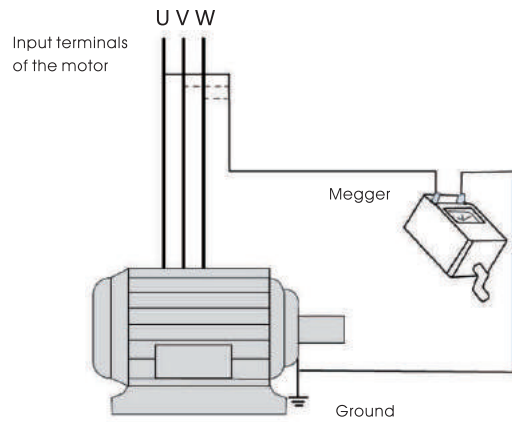

2) Thermal protection of motor

If the rated capacity of the motor selected does not match that of the AC drive, especially when the AC drive's rated power is greater than the motor's, adjust the motor protection parameters on the operation panel of the AC drive or install a thermal relay in the motor circuit for protection.

3) Motor heat and noise

The output of the AC drive is pulse width modulation (PWM) wave with certain harmonic frequencies, and therefore, the motor temperature, noise, and vibration are slightly greater than when the drive runs at power frequency (50 Hz).

4) Voltage-sensitive device or capacitor on output side of the AC drive

Do not install the capacitor for improving power factor or lightning protection voltage sensitive resistor on the output side of the AC drive because the output of the AC drive is PWM wave. Otherwise, the AC drive may suffer transient overcurrent or even be damaged.

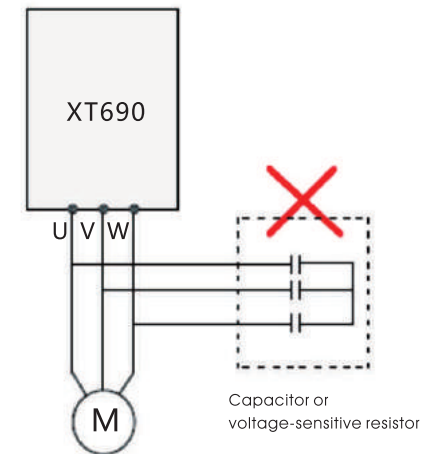

5) Contactor at the I/O terminal of the AC drive

When a contactor is installed between the input side of the AC drive and the power supply, the AC drive must not be started or stopped by switching the contactor on or off. If the AC drive has to be operated by the contactor, ensure that the time interval between switching is at least one hour since frequent charge and discharge will shorten the service life of the capacitor inside the AC drive.

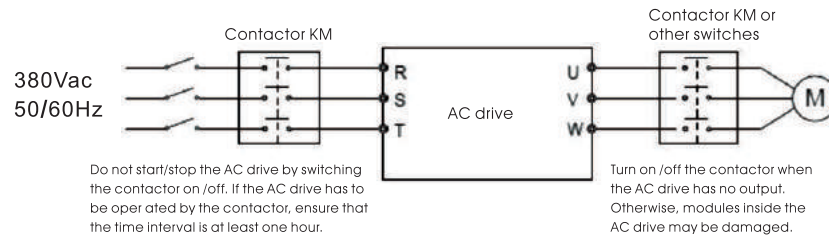

6) When external voltage is out of rated voltage range

The AC drive must not be used outside the allowable voltage range specified in this manual. Otherwise, the AC drive's components may be damaged. If required, use a corresponding voltage step-up or step-down device.

7) Prohibition of three-phase input changed into two-phase input

Do not change the three-phase input of the XT690 series servo drive into two-phase input. Otherwise, a fault will result or the servo drive will be damaged.

8) Surge suppressor

The drive internal installed varistor, can inhibit the surge voltage the inductive load on/off around drive. When the inductive load produced large surge voltage energy, please be sure to use surge suppressor on the perceptual load or using diode at the same time.

Note: The surge suppressor can not be connected to the output terminal of the servo driver.

9) Altitude and de-rating

In places where the altitude is above 1000 m and the cooling effect reduces due to thin air, it is necessary to de-rate the AC drive. Contact XINGTAI for technical support.

10) Some special usages

If wiring that is not described in this manual such as common DC bus is applied, contact the agent or XINGTAI for technical support.

11) Disposal

The electrolytic capacitors on the main circuits and PCB may explode when they are burnt. Poisonous gas is generated when the plastic parts are burnt. Treat them as ordinary industrial waste.

12) Adaptable Motor

The standard adaptable motor is Permanent Magnet Synchronous Motor(PMSM);

The standard parameters of the adaptable motor have been configured inside the servo drive. It is still necessary to perform motor auto-tuning or modify the default values based on actual conditions. Otherwise, the running result and protection performance will be affected.

The servo drive may alarm or even be damaged when short-circuit exists on cables or inside the motor. Therefore, perform insulation short-circuit test when the motor and cables are newly installed or during routine maintenance. During the test, make sure that the AC drive is disconnected from the tested parts.

13) precautions for use

When drive over flow(Err02/Err03/Err04) and over load(Err10) fault, if you start running again, the fault come again, Make sure to check the cause first, do not start frequently, Otherwise drive inverter modules will be damaged by large current shock.

2

产品信息

Product Information

Chapter 2 Product Information

2.1 XT690 servo drives name rules

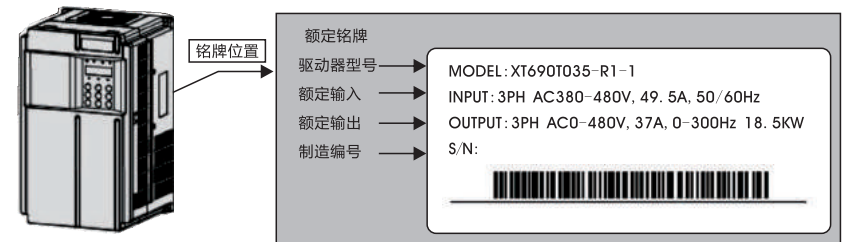
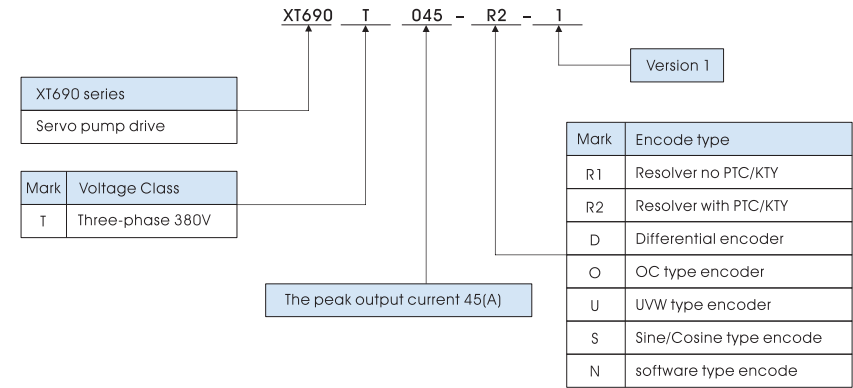

Picture 2-1 XT690 servo drives name rules

Note: XT690 series servo drive with rotary transformer PG card.

2.2 XT690 servo drives specification

Model No.	Input Voltage	Input current (A)	Rated output current(A)	Remark
XT690T045	Three phase 380V (-20%~20%)	23.0	22.0	150% Rated current 60S 180% Rated current 3S
XT690T070		35.0	32.5	
XT690T085		39.0	37.5	
XT690T090		46.0	45.5	
XT690T110		52.0	51.0	
XT690T130		62.0	61.0	
XT690T170		76.0	75.5	
XT690T240		113.0	112.5	
XT690T320		157.0	155.5	

2.3 Technical Specifications

Items		Specifications
General functions	Maximum frequency	800Hz
	Carrier frequency	1 kHz~16kHz;
	Input frequency resolution	Digital setting:0.01Hz Analog setting:maximum frequency x 0.1%
	Control mode	Closed-loop vector control(VC) Voltage/Frequency control(V/F)
	Startup torque	0Hz/180%(VC)
	Speed range	1:1000 (VC)
	Speed stability accuracy	±0.02%(VC)
	Torque control accuracy	±5%(VC)
	V/F curve	Linear type ;
	acceleration and deceleration curves	Linear,S curves,ST curves
	overload capacity	150% rated output current 60s;180% rated output current 3s.
	Motor overheat protection	KTY84 temperature protection
Encoder types	Software encoder,rotary transformer,ABZ optical-electricity encoder,multi-turn type absolute encoder	
Protect functions	Protect functions	Motor short circuit protection,Input and output phase loss protection,overcurrent protection, overvoltage protection,low-voltage protection, Overheat protection,overload protection.etc
Communication function	Modbus	Support Modbus-RTU protocol
	CAN	Support CANOpen,CANLINK communication protocol
Environment	Installation location	Indoor, free from direct sunlight, dust, corrosive gas, combustible gas, oil smoke, vapour, drip or salt.
	Altitude	Lower than 1000m
	Ambient temperature	-10℃~+40℃ (If 40℃~50℃ , please derating use)
	Humidity	Less than 95%RH, without condensing
	Vibration	Less than 5.9 m/s ² (0.6 g)
	Storage temperature	-20℃~+60℃
IP level	IP20	

3

机械与电气安装

Mechanical and Electrical Installation

Chapter 3 Mechanical and Electrical Installation

3.1 Mechanical Installation

3.1.1 Installation Environment Requirements

- 1) Ambient temperature: -10°C to $+50^{\circ}\text{C}$;
- 2) Heat dissipation: Install the AC drive on the surface of an incombustible object, and ensure that there is sufficient space around for heat dissipation. Install the AC drive vertically on the support using screws.
- 3) Vibration: Less than 0.6 g, Far away from the punching machine or the like.
- 4) Free from direct sunlight, high humidity and condensation
- 5) Free from corrosive, explosive and combustible gas
- 6) Free from oil dirt, dust and metal powder

3.1.2 Installation Clearance Requirements

The clearance that needs to be reserved varies with the power class of the XT690, as shown in the following figure.

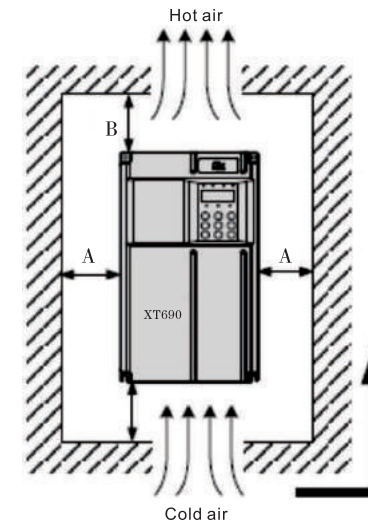

Installation clearance requirements on the XT690 series servo drives of different power classes

Power Class	Clearance Requirements	
0.4–15kw	A ≥ 10 mm	B ≥ 100 mm
18.5–22kw	A ≥ 10 mm	B ≥ 200 mm
22–37kw	A ≥ 50 mm	B ≥ 200 mm
37–630kw	A ≥ 50 mm	B ≥ 300 mm

Picture 3-1 Clearance around the MD380 for installation

The XT690 series servo drive dissipates heat from the bottom to the top. When multiple servo drives are required to work together, install them side by side. If multiple servo drives are connected together, install them side by side. If one row of servo drives need to be installed above another row, install an insulation guide plate to prevent servo drives in the lower row from heating those in the upper row and causing faults.

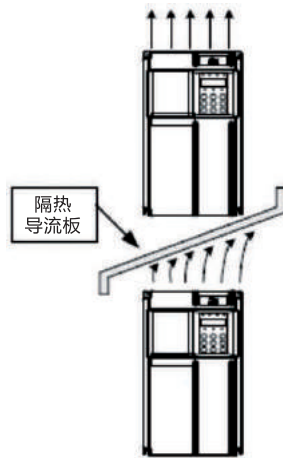

Picture 3-2 Installation of the insulation guide plate

3.1.3 Mechanical Installation Method and Process

The XT690 series servo drives have two housing types, plastic housing and sheet metal housing, according to different voltage and power classes. The XT690 supports both wallmounting installation and embedded installation in different applications.

1) Wall-mounting installation of the XT690 (XT690T045***~XT690T320) (sheet metal housing)

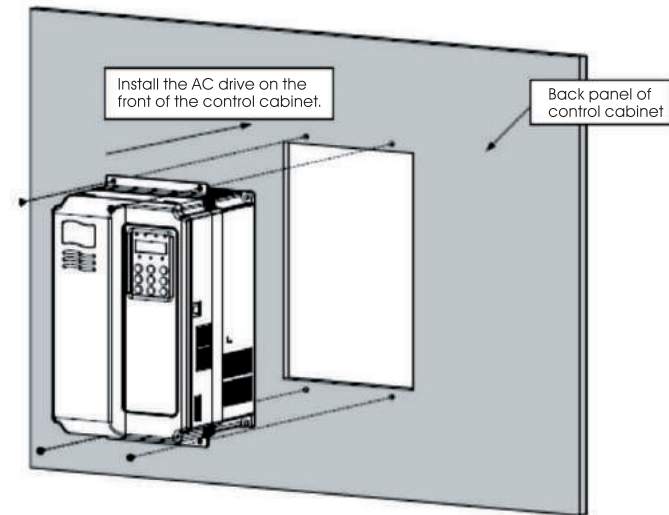

Picture 3-3 Wall-mounting installation of the XT690 (sheet metal housing)

2) Embedded installation of the XT690 (XT690T045***~XT690T320) (sheet metal housing)

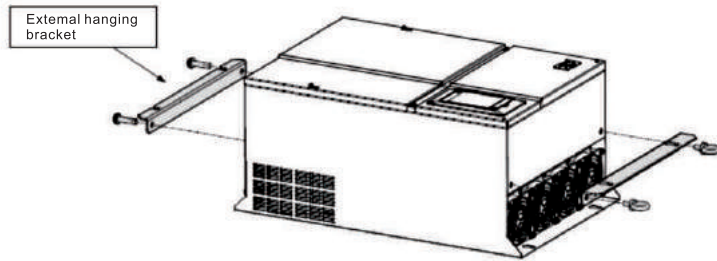

Picture 3-4 External hanging bracket for the XT690 (sheet metal housing)

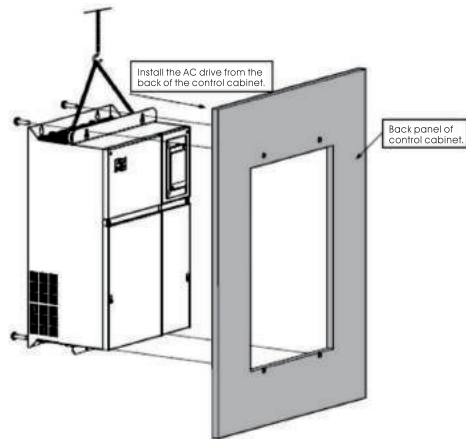

Picture3-5 Embedded installation of the XT690 (sheet metal housing)

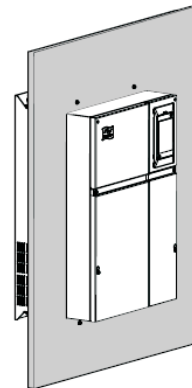

Picture3-6 Embedded installation effect of the XT690 (sheet metal housing)

3.1.4 XT690 Installation Precautions

- 1) Reserve the installation clearances as specified in Picture 3-1 to ensure sufficient space for heat dissipation. Take heat dissipation of other parts in the cabinet into consideration.
- 2) Install the servo drives upright to facilitate heat dissipation. If multiple servo drives are installed in the cabinet, install them side by side. If one row of servo drives need to be installed above another row, install an insulation guide plate, as shown in Picture 3-2.
- 3) Use the incombustible material for the installation support.
- 4) It is suggested to increase the IP level of the cabinet in scenarios with heavy metal powder. For example, seal the cabinet door and attach a filter to the cooling fan.

3.1.5 Removal and Installation of the Front Cover of the XT690

For the XT690 series servo drives, you need to remove the front cover and before wiring the main circuit and control circuit.

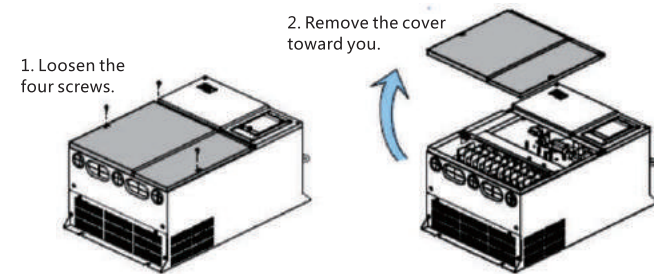

Picture 3-12 Removal of the front cover of the XT690 (XT690T045***~XT690T320) (sheet metal housing)

⚠️ DANGER

◆ Prevent the cover from falling off during the removal. Otherwise, damage to the equipment or personal injury may result.

3.2 Mechanical Installation

Please refer to the picture in the Introduction P8.

3.3 Main Circuit Terminals and wiring

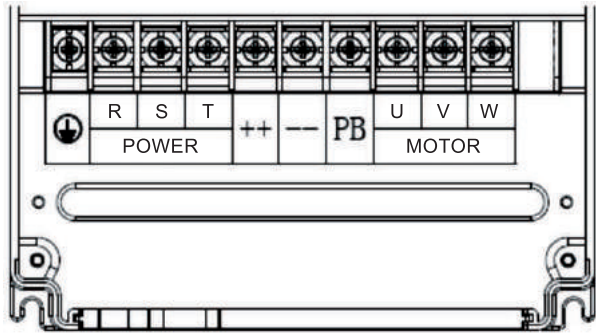

Picture 3-13 Main Circuit Terminals

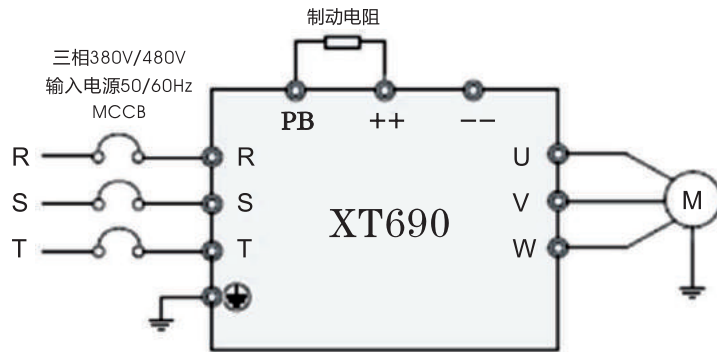

Picture 3-14 Three phase380~480V drive main circuit wiring diagram

Description of main circuit terminals:

Terminal	Name	Description
R, S, T	Three-phase power supply input terminals	Connect the three-phase AC power supply
++, --	Positive and negative terminal of DC bus	Common DC bus input point. Connect external braking unit to the AC drive of 90 kW and above.
++, PB	Connecting terminals of braking resistor	Connect the braking resistor for the AC drive of 75 kW and below
U, V, W	drive output terminals	Connect a three-phase motor.
⊕	Grounding terminal	Must be grounded.

3.4 Control circuit terminals and wiring



1) Description of the use of control circuit terminals

Item	Terminal Symbols	Terminal Definition	Description
Analog input	A1-AGND	Analog input terminal 1 (Default flow given signal)	1. Input range: $\pm 10V$, resolution 12, correction accuracy 0.5% 2. Input impedance 100K Ω .
	A2-AGND	Analog input terminal 2 (Default pressure signal)	1. Input range: $\pm 10V$, resolution 12, correction accuracy 0.5% 2. Input impedance 100K Ω .
	A3-AGND	Analog input terminal 3 (Default pressure sens or input terminal)	1. Input range: $\pm 10V$, resolution 12, correction accuracy 0.5% 2. Input impedance 100K Ω .
	KTY84+KTY84-	Motor overheat protection input	Motor overheat protection KTY sensor, support:KTY84
Digital input	In1 ~ In5-CGND	Digital input	1. Isolate the drain-source input programmable terminals, input frequency < 100Hz; 2. Resistance input: 3.3k Ω ; 3. Voltage range for level input: 9V~30V.
Communication terminals	CANH/ CANL/ TGND	CAN communication terminals	Maximum communication speed 1 Mbps. The Control board J2 jog choose to connect terminal resistance
	485B/485A/ TGND	485 communication terminals	Note:keep terminal,default no this function,maximum communication speed 500Kbps,with Isolation.
Analog output	DA1-AGND	Analog output 1	Output voltage range:0-10V, resolution12,correction accuracy 1%, Maximum load resistance $\leq 500\Omega$.
	DA2-AGND	Analog output 2	Output voltage range:0-10V, resolution12,correction accuracy 1%, Maximum load resistance $\leq 500\Omega$.
Relay output	N1C/N1G/N1O	NO/NC terminal	Contact driving capacity: AC250V,3A,/ DC 30V,1A.
	N2G/N2O	NO terminal	

3.5 PG Card termical descriptions

Number	Name	Description	PGCard terminal pin definition
10	REF+	drive signal	
5	REF-		
8	SIN+	SIN feedback signal	
3	SIN-		
9	COS+	COS feedback signal	
4	COS-		
14	KTY84+	motor temperature signal	
7	KTY84-		

Note:XT690 Series Servo Driver matched Encode Signal Wires Definition (FYI)

Signal Definition	REF+	REF-	SIN+	SIN-	COS+	COS-	KTY84+	KTY84-
Signal wire color	white	green	blue	yellow	gray	red	Light blue	brown
CorrespondingPG Card DB15 pin	10	5	8	3	9	4	14	7

3.6 Operation Panel

XT690 series servo drive with a LED operation board, By 4core ribbon cable contact to drive 4core socket. You can modify the parameters, monitor the working status and start or stop the XT690 by operating the operation panel, as shown in the following figure.

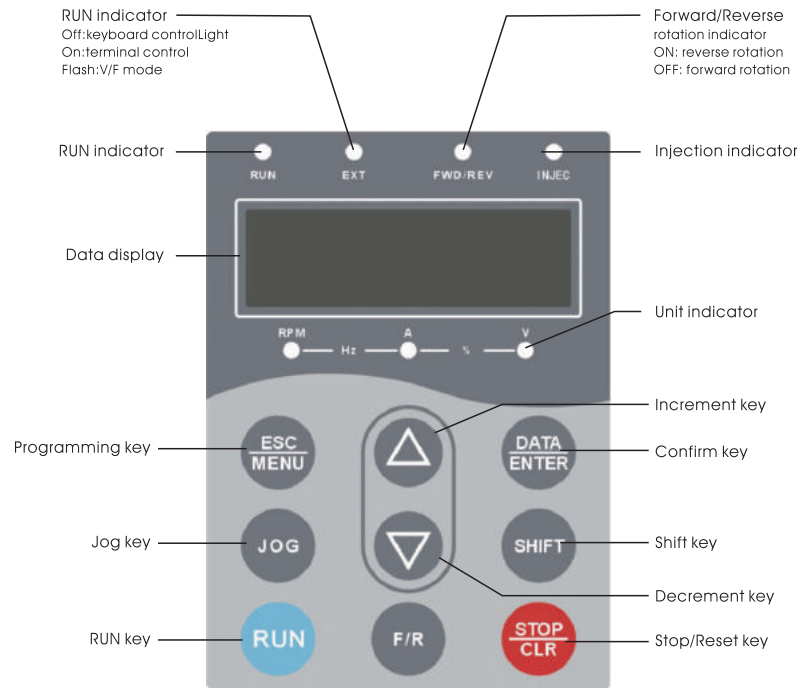

Picture 3-20 LED Diagram of the operation panel

3.6.1 Description of Indicators

RUN: ON indicates that the servo drive is in the running state, and OFF indicates that the servo drive is in the stop state.

EXT: Keyboard operation, terminal operation and remote operation (communication control) indicator.

INJEC: Injection plastic indicator.

3.6.2 Digital Display

The 5-digit LED display is able to display the set frequency, output frequency, monitoring data and fault codes.

Description of Keys on the Operation Panel:

Table 3-2 Description of Keys on the Operation Panel

Key	Name	Function
	Programming	Enter or exit Level I menu.
	Confirm	Enter the menu interfaces level by level, and confirm the parameter setting.
	Increment	Increase data or function code.
	Decrement	Decrease data or function code.
	Shift	Select the displayed parameters in turn in the stop or running state, and select the digit to be modified when modifying parameters
	Run	Start the servo drive in the operation panel control mode.
	Stop/Reset	Stop the servo drive when it is in the running state and perform the reset operation when it is in the fault state.
	Jog	Press this key to jog when in the operation panel control mode.
	Forward/Reverse	Press this key to change the motor run direction when in the operation panel control mode

3.6.3 Operate panel LED digital tube and indicator light instruction

On the operation panel there is five digits eight segment LED digital tube, 3 units indicator, 4 status indicators.

- Digital tube could display the drives' status parameter, function code parameter, error alarm code.etc
- 3 Units indicator light Corresponding to 6 kinds of units display, r/min, A, V light turn on Corresponding show r/min, A, V of this 3 kinds of units.
- 4 status indicator lights are RUN, REV, EXT, INJEC indicator.
REV light on means reverse (RUN light on but REV off means FWD; RUN light on and REV on also means reverse), INJEC is injection action indicator. RUN and EXT indicator instruction see below table.

Table 2 RUN and EXT indicator instruction

Indicator	Status	Indicate Drive current status
RUN	off	Stopped status
	on	Running status
EXT	off	Operate panel control status
	on	AD terminal control status
	flash	Speed control mode parallel operation control status

3.6.4 Operate panel display status

Operate panel display status including: stopped status parameter display, running status parameter display, error alarm status display, function code parameter edit status display, etc.

(1) Stopped status parameter display

Under Operate panel control mode, display bus voltage (SHIFT key switch bus voltage and setting speed).

Under other mode, drive ENABLE not open, 0 flash. ENABLE on, display current speed (SHIFT key switch speed and output current).

(2) Running status parameter display

The drive get the effective run command, into running status, operate panel display RUN status parameter, RUN indicator on, REV on or off decided by current running direction.

(3) Error display status

Once Drive detected error signal, into error alarm status, display the error code.

(4) Function code parameter status

When stopped, running or error alarm status, press MENU/ESC key, all can into function code edit status, edit status display as two levels of menu. The order is: function code no. → function code parameter, press ENTER/DATA key into function parameter display status. Under function parameter display status, press ENTER/DATA key to data storage, Press MENU/ESC key to reverse exit.

※Notice: If not storage, exit directly, Modify parameter is invalid.

3.6.5 Operate the operate panel

Through operate panel, can do any operate to drive. For example:

Adjust AD mode (0-10V input) MAX running speed

eg: Set max speed 2000r/min to be 2400r/min.

1) Any condition after drive power on, press ESC/MENU key into edit status, press SHIFT key and ▲▼ key switch to set max speed display status (01-03 units), press DATA key into speed modify status.

2) Press ▲▼ key to modify set speed, (press SHIFT key to move modify decimals) 2000 to 2400.

3) Press DATA/ENTER key to save the modified data, modify success! Press ESC/MENU key exit edit status.

3.6.6 Function code simple list

Instruction: * means this parameter is "factory parameter", Confined to the manufacturer's Settings, forbid user operation.

Table 3 Function code ID and name table

Function code	Function code name
00	System set
01	Basic parameter
02	Motor parameter
03	Drive parameter
04	Inner parameter
05	Oil circuit parameter
06	action PID
07	Reserve
08	Reserve
09	Reserve
10	Reserve
11	Error record
12	Reserve
13	Reserve
14	Reserve
15	Reserve

3.6.7 Starting or Stopping the servo Drive

1) Selecting the Start/Stop Command Source

There are three start/stop command sources, namely, operation panel control, terminal control, and communication control. You can select the command source in 01-06.

01-06	Parameter Name		Factory setting: 1	Description
	Setting Range	0	Operation panel control(LED OFF)	Press RUN. STOP to start or stop the servo drive.
		1	Terminal control(LED ON)	A DI terminal needs to be defined as the run/stop terminal.
		2	Communication control(LED Flash)	MODBUS-RTU protocol or CAN bus

● Operation panel control

Operate the keyboard, setting 01-06=0, is operation panel Start/Stop control mode. After you press RUN, the servo drive starts running (the RUN indicator is ON). After you press STOP when the servo drive is in running state, the servo drive stops running (the RUN indicator is OFF).

● Terminal control

This control mode is applicable to scenarios where the DIP switch or electromagnetic button is used to start or stop the application system or scenarios where the dry contact signal is used to start or stop the AC drive. The input terminal of the start/stop signal is set in 01-06.

3.6.8 Motor Rotating Direction Setting

After the servo drive restores the default settings, set the motor parameters, and motor self-learning finished, Press RUN drive the motor to rotate, In this case, the rotating direction is regarded as the forward rotation. If the rotating direction is reverse to the direction required by the equipment, power off the AC drive and exchange any

two of the output UVW cables (wait until the main capacitor of the AC drive is completely discharged)

4

伺服油泵快速调试

The Servo Pump Fast Debugging

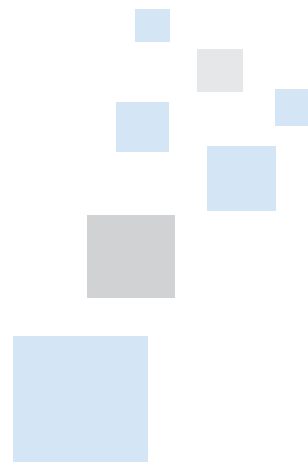

Chapter4 Servo Pump Fast Debugging

4.1 Servo Pump Debugging Process

Servo Pump Debugging mainly including motor self-learning, motor trial running and servo oil pressure debugging. Details as below:

Motor self-learning: static state self-learning and dynamic state self-learning.

Before self-learning, please shift the drive to operation panel control mode (01-06=0)

1) Static state self-learning (Motor no running)

Static state self-learning: Input the data on the motor sheet to the drive, the drive will work out the data of motor internal loop. Due to the different length and different direction of installed cable will affect motor resistance and inductance, this normally used in where is no high accuracy requirement.

Input below parameter :

Item	Description	Parameter	Note
1	Motor rated current	02-02	Check motor parameter table
2	Resistance	02-04	Check motor parameter table
3	Inductance	02-05	Check motor parameter table
4	Thousand turn/counter EMF	02-07	Check motor parameter table
5	Rotational inertia	02-00	Check motor parameter table

2) Dynamic state self-learning. (Motor running)

A. Separate motor and oil pump (Release the coupling)

B. Input motor rated current (02-02)

C. Set 02-10=4 [wait 3 minutes to see the run indicator off, self-learning finish.]

The servo drive will recognize the the parameter of motor resistance, inductance, Thousand turn/counter EMF, rotational inertia.

4.2 Trial running check

1) After self-learning, set 01-01 = 100 test run at low speed, observe the running current of drive is small and steady or not.

2) If the running current is big, please check the motor parameter setting is right, if there is change, please re-self-learning and low speed test again to check whether it is normal running.

3) After self-learning running in normal situation, check the drive running direction is right, if wrong, please swift U- W two-phase wiring of motor, and making motor parameter self-learning once again.

4) When motor running, if the motor vibrating or there is a deep voice out, please adjust 06-05 speed loop bandwidth (200-400HZ), default is 300HZ.

4.3 Servo pump application debugging

The drive shift to terminal control mode (set 01-06 = 1)

1) Set pressure loop P (06-00 = 0.5) system on pressure, check pressure gauge stable or not at 50KG, 100KG, 140KG. If not or vibrating, adjust 06-05 speed loop bandwidth (200-400HZ), default 300HZ. Normally adjust to the pressure a vibrating or motor comes out deep voice, decrease the bandwidth of speed loop to its 70-80%.

2) Properly increase the pressure loop P (06-00), improve the pressure response speed, normally less than 2.0.

4.3.1 Oil pressure function parameter setting

System oil pressure and flow corresponding setting.

1) System oil pressure and flow setting

Related Function code parameter description:

01-02 System oil pressure, set the maximum pressure of system

Set the Pressure range of pressure sensor, corresponding to the voltage 0 ~ 10Vdc Output type pressure sensor.

2) AI2 Flow instruction corresponding setting.

Related Function code parameter description:

03-14 Minimum setting flow minimum instruction, default 0.0%, means 0 flow;

03-15 Maximum input flow instruction, minimum pressure input, normally 10V input;

to set flow instruction 0V ~ 10V (or other range), corresponding 0 rmp ~ maximum speed (01-03);

3) Release pressure setting(Parameter code:05-11).

Parameter code	Description	Details
05-11	Maximum reverse speed	Maximum reverse speed when release pressure,related to maximum speed(05-11). The parameter data bigger,release pressure faster, But to big will cause oil pump reverse noise;the data smaller, release pressure slower.

4) base pressure and base flow setting (Parameter code :05-00, A3-10) :

Parameter code	Description	Details
05-00	base pressure	Setting range: 0.0 kg/cm2 ~ 50.0 kg/cm2
05-05	base flow	Setting range: 0% ~ 20%, corresponding maximum speed(01-03)percent setting.
05-04	base pressure and base flow hold time	Every motion finished hold time (0-180S)

5) pressure and flow instruction filter time

Parameter code	Description	Details
06-16	Flow rise S filter time	0.001-1.0s
06-17	Flow decreased S filter time	0.001-1.0s
06-18	Pressure rise S filter time	0.001-1.0s
06-19	Pressure decreased S filter time	0.001-1.0s
07-16	Injection--Flow rise S filter time	0.001-1.0s
07-17	Injection--Flow decreased S filter time	0.001-1.0s
07-18	Injection--Pressure rise S filter time	0.001-1.0s
07-19	Injection--Pressure decreased S filter time	0.001-1.0s

Reduce filter time,Oil pressure response will be faster,running impact will be bigger, otherwise ,Oil pressure response will be slower,running will be smooth.

4.3.2 Oil pressure PID response adjust

Oil pressure PID mode choose

1) Oil pressure PID mode 1:DI Choose PID group mode

2) The drive offer 2 group PID,according to the choose of Input terminal IN2 ,seperately corresponding with injection motion and other motion.

CGND and IN2 not connect, First group PID:other motion.

CGND and IN2 connected ,Second group PID:injection motion,corresponding the drive operation panel INJIC Led light on.

3) Oil pressure PID proportional gain(parameter code:other motion 06-00,injection motion 07-00)

Proportional gain higher,presure response faster,but gain too much will cause system oscillation,otherwise pressure response slower.

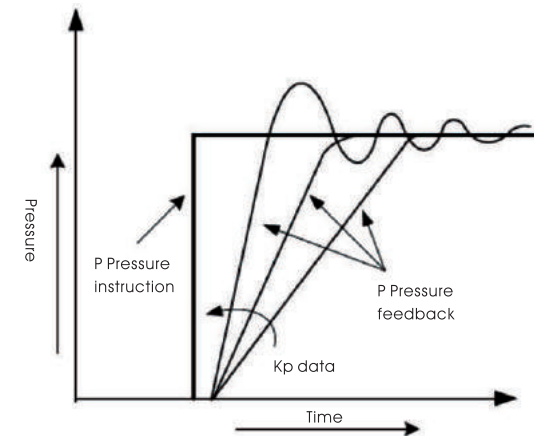

Picture 4-3 Oil pressure PID proportional gai

4) Oil pressure PID integral time(parameter code:other motion 06-01 injection motion 07-01)

Integral time smaller, pressure response faster, but may cause overshoot, too much will cause system oscillation; otherwise pressure response slower, too week may cause pressure instability.

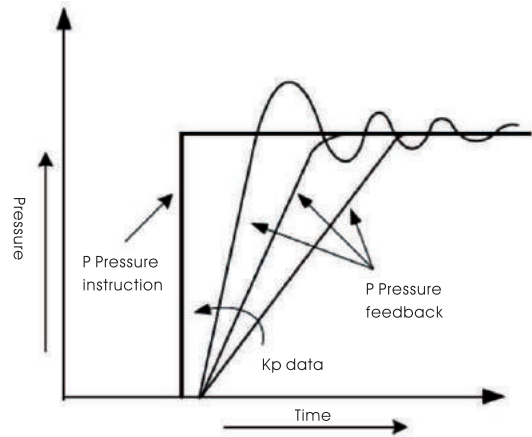

Picture 4-4 Oil pressure PID integral time

4.3.3 Keeping pressure stability debugging

If Keeping pressure fluctuate big when debugging, please enlarge the speed loop response frequency (200-400HZ) to improve the pressure stability. That is :properly increase 06-05 parameter data, decrease 06-00 parameter data(injection motion adjust 07-05,07-00). Pay attention to the appropriate adjustment range, otherwise the motor control will fluctuate,

5

伺服油泵快速调试

The Servo Pump Fast Debugging

Chapter 5 Maintenance and fault diagnosis

5.1 The drive routine maintenance and repair

5.1.1 Routin maintenance

The influence of the ambient temperature, humidity, dust and vibration will cause the aging of the devices in the servo drive, which may cause potential faults or reduce the service life of the servo drive. Therefore, it is necessary to carry out routine and periodic maintenance.

Routine maintenance involves checking:

- Whether the motor sounds abnormally during running.
- Whether the motor vibrates excessively during running.
- Whether the installation environment of the servo drive changes.
- Whether the servo drive's cooling fan works normally.
- Whether the servo drive overheats.

Routine cleaning involves:

- Keep the servo drive clean all the time.
- Remove the dust, especially metal powder on the surface of the servo drive, to prevent the dust from entering the servo drive.
- Clear the oil stain on the cooling fan of the servo drive.

5.1.2 Periodic Inspection

Perform periodic inspection in places where inspection is difficult.

Periodic inspection involves:

Check and clean the air duct periodically.

Check whether the screws become loose.

Check whether the AC drive is corroded.

Check whether the wiring terminals show signs of arcing;

Main circuit insulation test

Prompt :

Before measuring the insulating resistance with megameter (500 VDC megameter recommended), disconnect the main circuit from the AC drive. Do not use the insulating resistance meter to test the insulation of the control circuit. The high voltage test need not be performed again because it has been completed before delivery.

5.1.3 Replacement of Vulnerable Components

The vulnerable components of the servo drive are cooling fan and filter electrolytic capacitor. Their service life is related to the operating environment and maintenance status. Generally, the service life is shown as follows:

Component	Service Life
Fan	2 ~ 3 years
Electrolytic capacitor	4 ~ 5 years

Note: Standard replacement time is based on below conditions, the user could see the running time to determine the replacement years.

- Environment temperature: The average annual temperature is 30°C around.
- Load rate: less than 80%.
- Operation rate: less than 20 hours/day.

1) Cooling Fan

- Possible cause of damage: Bearing wear, vane burn-in.
- Distinguish standard: Fan blade with crack or not, if there's any abnormal vibration sound when the drive is on.

2) Filtering electrolytic capacitor

- Possible damage reasons: poor quality of the input power supply, high environmental temperature, frequent load jump, Electrolyte aging.
- Distinguish standard: if there is liquid leakage, relief valve whether bulge, The electrostatic capacitance measurement, The insulation resistance measurement.

5.1.4 Storage of the servo drive.

For storage of the AC drive, pay attention to the following two aspects:

1) Pack the AC drive with the original packing box provided by Inovance.

2) Long-term storage degrades the electrolytic capacitor. Thus, the servo drive must be energized once every 2 years, each time lasting at least 5 hours. The input voltage must be increased slowly to the rated value with the regulator.

5.2 Warranty Agreement

1) Free warranty only applies to the AC drive itself.

2) XINGTAI SERVO will provide 18-month warranty (starting from the leave-factory date as indicated on the barcode) for the failure or damage under normal use conditions. If the equipment has been used for over 18 months, reasonable repair expenses will be charged.

3) Reasonable repair expenses will be charged for the damages due to the following causes:

- Improper operation without following the instructions
- Fire, flood or abnormal voltage.
- Using the servo drive for non-recommended function

4) The maintenance fee is charged according to Inovance's uniform standard. If there is an agreement, the agreement prevails.

5.3 Faults and Solutions

The XT690 servo drive provides warning information and protective function. After a fault occurs, the servo drive stops outputting, the fault relay contacts, and the servo drive implements the protection function, and displays the fault code on the operation panel (if the operation panel is available). Before contacting XINGTAI for technical support, you can first determine the fault type, analyze the causes, and perform troubleshooting according to the following tables. If the fault cannot be rectified, contact the agent or XINGTAI.

5.4 The common faults and solutions

The servo drive may occur below faults, please find below solution to simply fault analysis:

Common faults		
Er-01	overcurrent	Check the configuration is reasonable or not, the encoder line is contact well or not, The drive output to the motor is good contact or not.
Er-02	overload	Check the configuration is reasonable or not, The hydraulic valve is stuck or not, Whether there is an action keeping the highest pressure for a long time.
Er-03	Bus Low voltage	Check whether the input voltage is lower than the minimum limited pressure
Er-04	Bus high voltage	Test the brake resistor is normal or not, test the value of resistance and check the connection.
Er-05	Input 380V phase loss	Check whether the power input is lack of phase or not.
Er-06	Encoder Error	Check whether encoder line on both ends are wired normal.
Er-07	Motor phase failure	Check the motor UVW terminals and the drive UVW terminals are one to one correspondence connected.
Er-08	Retain	
Er-09	braking fault	Check the braking resistance is normal working, test the value of resistance and check the connection.
Er-10	Motor overtemperature	Check the motor fan is normal, whether the air duct blockage, whether cooperate with the oil pump is reasonable, whether the temperature line connection correct (temperature line consist in the encoder line)
Er-11	Drive overtemperature	Check the Drive installation is as per the requirements, ensure the drive Ventilation is normal.
Er-12	Retain	
Er-13	Module protect	Check Connecting to motor is normal, the output is short circuit or not.
Er-14	Control mode error	Retain
Er-15	Current offset transfinite	Retain
Er-16	The output phase loss	The drive output to motor is phase loss or not.
Er-17	Overspeed protection	Speed ultralimit
Er-18	motor parameter recognition failure	Self-study again
Er-19	motor inertia recognitio failure	Self-study again
Er-20	Retain	Retain

Chapter 6 XT servo motor user manual (Voltage classes:400V)

6.1 XT servo motor name rules

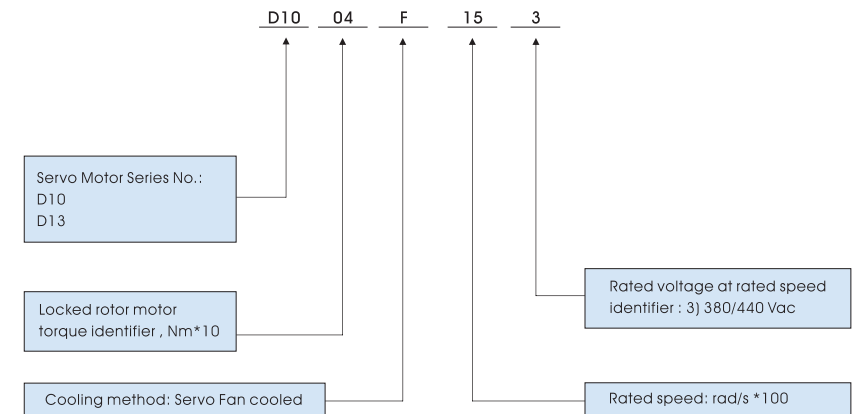

For example:D1004F.15.3 means D10 series motor,40Nm,1500rpm,380Vac.

Picture 6-1 XTDF servo drive name rules

Note:

- ◆ Motor working system definition:The motor working system is instruction of motor bear loading condition, it including start,electric braking,no-load,off to a halt and the duration and sequential inthese stages.
- ◆ S1 working system(IEC 60034-1):continuous working, Under constant load,the running long enough to reach thermal stability;
- ◆ S4 working system(IEC 60034-1):including the running intermiffent circle working,according to a series of the same cycle of operation, every circle including a period of start time which have remarkable influences to temperature rising ,a period of constant load running time and a period of off to a halt time .

6

XT伺服电机使用说明 (电压等级:400V)

XT servo motor user manual (Voltage Classes:400V)

6.2 Xingtai servo motor specification

XingTai Servo Motor Specification

Model No.	Rated torque	Locked rotor torque	Rated speed	Rated current	Locked rotor current	Rated power	Torque constant	Back EMF constant	Rated frequency	Line resistance	Line inductance	Rated voltage	Rotary inertia
	Nm	Nm	Rpm	Arms	Arms	KW	Nm/Arms	V/KRPM	Hz	Ohm	mH	V	kgm ² 10 ⁻³
D10F Series Servo Motor Specification													
D1004F.15.3	38	39	1500	11.6	12	6	3.32	200.7	100	1.67	16.33	350	6
D1004F.17.3	38.9	40.4	1700	15.2	15.8	7.6	2.81	169.9	113.4	1.19	16	381	6
D1004F.20.3	42	44	2000	18.8	19.6	8.7	2.37	143.3	133.4	0.85	8.33	321	6
D1005F.15.3	55	60.7	1500	16.6	20.2	8.6	3.31	200.1	100	0.97	14.6	300	6.1
D1005F.17.3	57	59.5	1700	20.4	23.3	10	2.81	169.9	113.4	0.72	10.6	336	6.1
D1005F.20.3	58	60.7	2000	24.3	25.7	12	2.6	157.2	133.4	0.6	9	364	6.1
D1007F.15.3	74	81.6	1500	23.9	26.5	11.6	3.37	203.8	100	0.665	11.4	329	9
D1007F.17.3	80	83	1700	28.2	31.8	14	2.85	172.3	113.4	0.48	8.09	341	9
D1007F.20.3	87	92	2000	36.7	38.3	18.2	2.53	153	133.4	0.356	4.74	341	9
D1008F.15.3	103	106.1	1500	33.2	34.6	16.4	3.38	204.4	100	0.473	9.05	370	9.8
D1008F.17.3	96.2	99.6	1700	35.1	36.8	17.6	2.98	180.2	113.4	0.417	7.04	370	9.8
D1008F.20.3	95.6	99.6	2000	40.1	42.5	20.4	2.58	156	133.4	0.314	5.29	370	9.8
D1010F.15.3	128	130.2	1500	41	42.9	20	3.3	199.5	100	0.338	7.38	360	12
D1010F.18.3	122	126.6	1800	44	48.7	23	2.87	173.5	120	0.273	5.42	312	12
D1010F.20.3	135	139	2000	60.5	61.8	28.3	2.37	143.3	133.4	0.181	2.78	321	12
D1013F.15.3	186	190	1500	61	63.8	29	3.26	197.1	100	0.249	3.7	370	15
D1013F.17.3	164.1	169.5	1700	55.4	58.5	28.7	3.19	192.9	113.4	0.236	5.03	380	15
D1013F.20.3	175	185	2000	73.7	77.3	36.7	2.53	153	133.4	0.144	2.37	340	15
D1015F.15.3	220	225	1500	72.73	80.93	37	3.096	187.2	100	0.180	4.029	370	19
D1015F.17.3	179.4	183.2	1700	65.24	67.38	33.5	3.03	182.9	113.4	0.229	3.737	380	14
D1015F.20.3	215	223	2000	96	106.8	49	2.322	140.4	133.4	0.103	2.266	371	19

Model No.	Rated torque	Locked rotor torque	Rated speed	Rated current	Locked rotor current	Rated power	Torque constant	Back EMF constant	Rated frequency	Line resistance	Line inductance	Rated voltage	Rotary inertia
	Nm	Nm	Rpm	Arms	Arms	KW	Nm/Arms	V/KRPM	Hz	Ohm	mH	V	kgm ² 10 ⁻³
D13F Series Servo Motor Specification													
D1315F.15.3	196	198	1500	71.48	72.51	31	3.015	182.3	100	0.169	6.458	378	27
D1315F.17.3	195.3	198.6	1700	72.91	82.37	35.9	2.98	180.2	113.4	0.132	3.695	370	26.4
D1315F.18.3	195	199	1800	78.81	80.31	39	2.75	166.3	120	0.113	3.148	370	26.4
D1315F.20.3	191	196	1500	97.76	100.2	43	2.154	130.2	133	0.089	3.295	380	27
D1320F.15.3	210	210	1500	62	62	33	3.43	207.4	100	0.098	4.46	369	36
D1320F.17.3	229	236	1700	92.6	98.3	39.4	2.94	177.8	113.4	0.107	4.5	377	36
D1320F.18.3	232	240	1800	96.46	99.8	44	2.64	159.6	120	0.085	3.647	379	36
D1320F.20.3	269	286	2000	120.7	127.8	56.3	2.37	143.3	133.4	0.068	2.13	347	36
D1330F.15.3	380	416	1500	106	117	60	3.56	215.2	100	0.082	3.19	380	49
D1330F.17.3	349	363	1700	145	153.4	62	2.89	174.7	113.4	0.06	2.9	368	49
D1330F.18.3	357.0	370.0	1800	146.5	151.8	67.0	2.68	162.0	113.4	0.050	2.46	379	49
D1330F.20.3	389.0	417.0	2000	155.3	165.6	81.4	2.67	161.4	133.4	0.046	1.80	386	49
D1340F.15.3	450.0	530.0	1500	130.0	158.0	70.0	3.56	215.2	100	0.058	2.40	347	63
D1340F.18.3	481.0	499.0	1800	196.0	203.3	91.0	2.71	163.8	113.4	0.035	1.864	379	63
D1340F.20.3	511.0	550.0	2000	230.0	246.0	107.0	2.37	143.3	133.4	0.026	1.060	341	63

6.3 XT servo motor overall dimension and installation

6.3.1 XT Servo motor Overall dimensions (180×180 motor base/ force-air cooling)

D10F Series Servo Motor Dimension

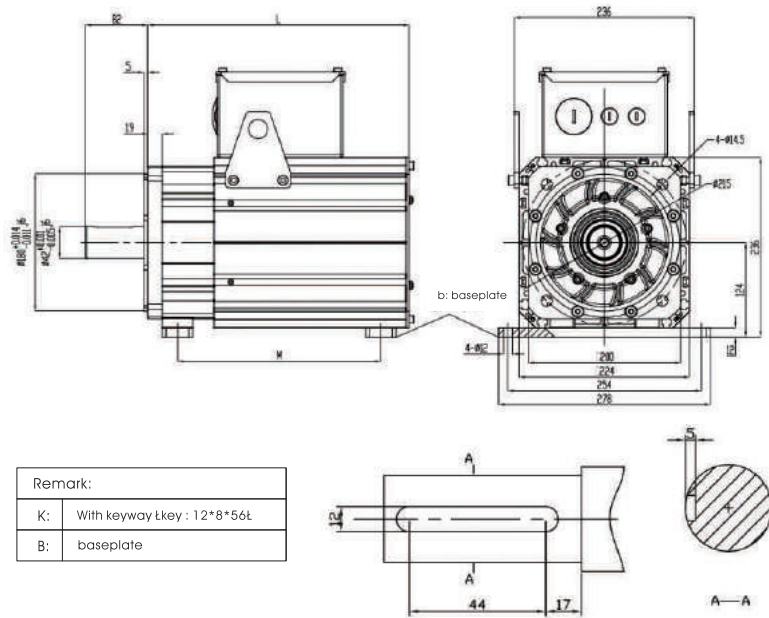

Code	M(mm)	L(mm)
D1004F	267	344
D1005F	285	379
D1007F	312	416
D1008F	354	457
D1010F	396	488
D1013F	471	559

D13F Series Servo Motor Dimension

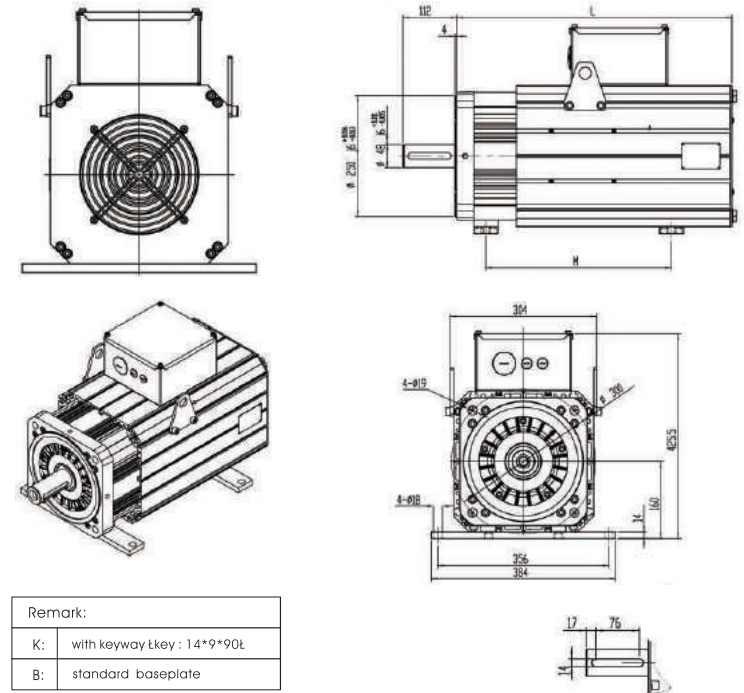

Code	M(mm)	L(mm)
D1315F	262	470
D1320F	370	577
D1330F	476	684
D1340F	583	791

6.4 Definition of power supply terminal which matched with PCB terminal block

When the main circuit wiring, phase sequence and identify on terminals must be consistent. PE connector please connect to the fixed screw identified in the terminal box.

Note:

- ◆ PTC、KTY and resolver signal line can not connect to 220V(will damage the motor);
- ◆ The motor pass IP54 test, but when wiring, the outlet hole must do protective processing and prevent objects into the motor.
- ◆ If there is sticky dust in the working environment, sticking on the motor surface, will affect the heat dissipation of the motor. Please refer to 6.6 to clean the draught fan.

6.5 Draught fan clean

The service life of fan: Fan service life estimation 40000 hours. (Under rated voltage, environment temperature 40°C, The fan continuous operation at full speed) If there is full of objects stucked on the draught fan, will degrade the performance of the fan, making the air volume smaller; if the air channel was blocked, the air resistance bigger, which also will result in the air volume smaller. Therefore, which affects motor cooling. When the motor winding temperature higher than motor protective temperature, the drive will report Er-10 (XT690 series servo drive) failure.

The fan cleaning procedures as follows:

1) Remove the 8 screws at the end of motor which used as the fan cover, and remove the cover;

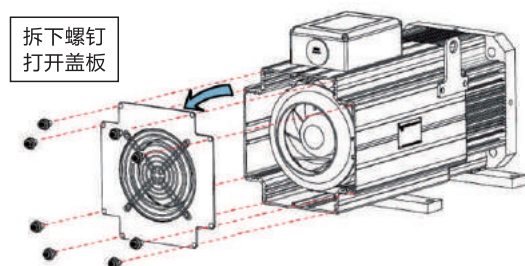

2) Use a small straight screwdriver to clean the surface objects, and the fan channel objects, to make sure there is no any objects resist the fan channel, then blow with a high pressure air rifle.

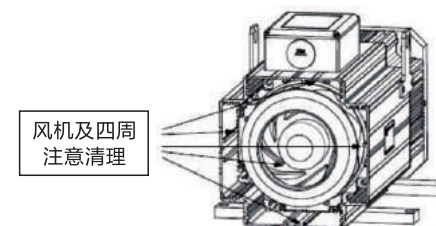

3) After cleaning well, please cover the cover, fasten with the screws to finish the clean job.

4) According to the actual situation to determine the fan clean frequentness.

7

XT690 伺服驱动器安装尺寸及其配件选型

XT690 Series Servo Drive Installation Size and Accessories Selection

Chapter7 XT690 Series Servo Drive Installation Size and Accessories Selection

7.1 XT690 series servo drive brake resistance selection

Model No.	Resistance (Ω)	resistor power	Remark
XT690T045	24	500W	
XT690T070	24	500W	
XT690T085	24	1000W	
XT690T090	24	1000W	
XT690T110	24	1500W	
XT690T130	24	1500W	
XT690T170	12	3000W	2*1500W in parallel
XT690T240	12	3000W	2*1500W in parallel
XT690T320	12	3000W	2*1500W in parallel
XT690T400	6	6000W	4*1500W in parallel
XT690T600	6	6000W	4*1500W in parallel
XT690T750	6	6000W	4*1500W in parallel

Table 7-2 brake resistance selection

7.2 XT690 series servo drive installation size

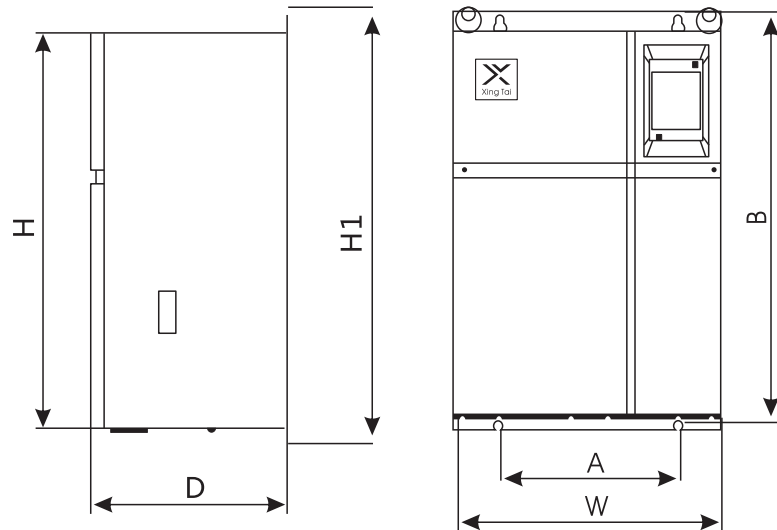

Picture 7-1 XT690 Series overall dimension and installation diagram

XT690 series servo drive overall dimension and mounting holes(mm)

Model No.	Install Hole (mm)		Overall dimension (mm)				Mounting hole diameter	Weight (Kg')
	A	B	H	H1	W	D		
XT690T045								
XT690T070	170	380	355	398	220	200	Φ6	14
XT690T085								
XT690T090								
XT690T120	217	415	400	432	265	215	Φ6	19
XT690T130								
XT690T170	280	465	450	480	330	225	Φ6	23
XT690T210								
XT690T240								
XT690T320	260	580	545	595	400	270	Φ10	32

8

EMC (电磁兼容性)

EMC (ElectroMagnetic Compatibility)

Chapter 8 EMC (Electromagnetic Compatibility)

8.1 Definition of Terms

EMC:

Electromagnetic compatibility (EMC) describes the ability of electronic and electrical devices or systems to work properly in the electromagnetic environment and not to generate electromagnetic interference that influences other local devices or systems. In other words, EMC includes two aspects: The electromagnetic interference generated by a device or system must be restricted within a certain limit; the device or system must have sufficient immunity to the electromagnetic interference in the environment.

- **First environment**

Environment that includes domestic premises, it also includes establishments directly connected without intermediate transformers to a low-voltage power supply network which supplies buildings used for domestic purposes.

- **Second environment**

Environment that includes all establishments other than those directly connected to a low-voltage power supply network which supplies buildings used for domestic purposes.

1) Category C1 drive

Power Drive System (PDS) of rated voltage less than 1 000 V, intended for use in the first environment.

2) Category C2 drive

PDS of rated voltage less than 1 000 V, which is neither a plug in device nor a movable device and, when used in the first environment, is intended to be installed and commissioned only by a professional.

3) Category C3 drive

PDS of rated voltage less than 1 000 V, intended for use in the second environment and not intended for use in the first environment.

4) Category C4 drive

PDS of rated voltage equal to or above 1 000 V, or rated current equal to or above 400A, or intended for use in complex systems in the second environment.

8.2 Introduction to EMC Standard

8.2.1 CE Mark

This drive marked CE mark, indicate that the drive comply with European low voltage directive and the provisions of the EMC directive.

8.2.2 EMC Standard

Xy690 series servo drive comply with below directive and standard:

Directive and standard

EMC Directive 2004/18/EC

EN 61800-3

EN 55011

EN 61000-6-2

LVD Directive 2006/95/EC

93/68/EEC

EN 61800-5-1

XT690 series servo drive comply the standard EN 61800-3:2004 C2, Suit for the first environment and the second environment.

8.2.3 Installation Environment EMC requirements

The system manufacturer using the AC drive is responsible for compliance of the system with the European EMC directive. Based on the application of the system, the integrator must ensure that the system complies with standard EN 61800-3: 2004 Category C2, C3 or C4. The system (machinery or appliance) installed with the AC drive must also have the CE mark. The system integrator is responsible for compliance of the system with the EMC directive and standard EN 61800-3: 2004 Category C2.

Warning

- ◆ If applied in the first environment, the AC drive may generate radio interference. Besides the CE compliance described in this chapter, users must take measures to avoid such interference, if necessary

8.3 Selection of Peripheral EMC Devices

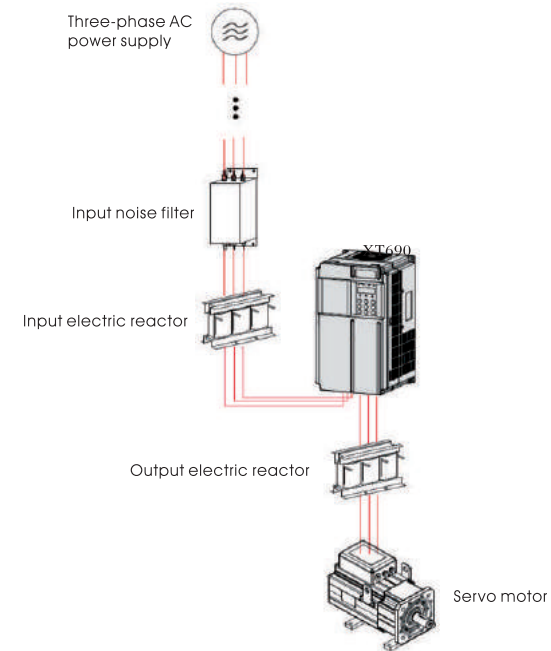

Picture 8-1 EMC Peripheral device installation

8.3.1 Installation of EMC Input Filter on Power Input Side

An EMC filter installed between the servo drive and the power supply can not only restrict the interference of electromagnetic noise in the surrounding environment on the servo drive, but also prevents the interference from the servo drive on the surrounding equipment.

The XT690 series servo drive satisfies the requirements of category C2 only with an EMC filter installed on the power input side. The installation precautions are as follows:

Strictly comply with the ratings when using the EMC filter. The EMC filter is category I electric apparatus, and therefore, the metal housing ground of the filter should be in good contact with the metal ground of the installation cabinet on a large area, and requires good conductive continuity. Otherwise, it will result in electric shock or poor EMC effect.

The EMC filter should be installed as closely as possible to the power input side of the servo drive.

Product warranty list

Client information	Company address:	
	Company name:	Contact person:
	Post code:	Tel:
Product information	Model No:	
	Agent name:	
Fault information	(Repare time and content):	
	Reparier:	

Fast Debug Method Guide

Method 1: Known Motor Parameter

1. Input motor rated current [02][02], Line resistance [02][04], Inductance[02][05], KRPM back EMF[02][07], Rotary Inertia[02][00]. For Xintai standard motor, please refer to Page 44 Servo motor specification.
2. Adjust[06][05]system response frequency, Small machinery(50cc pump below): 200-400HZ(default 300HZ), Middle size machinery(50cc-125cc pump); 150-300HZ(default 200HZ), big machinery (125ccpump) above : 120-250HZ(default 160HZ).
Generally adjust to the machinery vibrate critical value reduce 30% (Hot oil state).
If have connect injection action relay (the operate panel EJECT indicator light would turn on), then injection action adjust[07][05]unit.
3. Pressure loop P : [06][00], adjust range 0.5-2.5, default 1.5.
Pressure loop I : [06][01], adjust range 0.001-1, default 0.02.
Pressure loop P adjust pressure response speed, when pressure overshoot , adjust pressure loop I.
If have connect injection action relay (the operate panel EJECT indicator light would turn on), then injection action adjust[07][00]and[07][01]unit.

Method 2: Unknown motor parameter

- Motor parameter identification(Default 8pole motor)
1. Remove the oil pressure(Unscrew the hydraulic safety valve or release the coupling of motor and pump), let the motor free rotation.
 2. Set [01][06]=0 Into the panel control mode.
 3. Input motor rated current [02][02], if unknown , just estimate a value.
 4. Set [02][10]=4, wait 2-3 minutes, until the panel RUN indicator light turn off, then finish the motor parameter identification.
Motor will sun at 300rpm, the identified parameter are sperately saved at:
Line resistance [02][04], Inductance[02][05], KRPM back EMP[02][07], Rotary Inertia [02][00], Friction force[02][28].
 5. Set [01][06]=1 return to pressure control mode.
 6. Go on adjustment according to Method 1, start from step 2 .

Common used parameter units

Unit	Function	Setting range	Default
[01][02]	Set system Max Pressure	0-250kg/cm2	140 kg/cm2
[01][03]	Set the speed under max voltage	0-2500rpm	2000 rpm[MAX=rated speed+450]
[01][06]	Set Control command channel 0 Panel board 1 Pressure 2 Slave	0-2	1
[02][00]	Set Motor rotary inertia		Check the motor specification table or self-learning
[02][02]	Set Motor rated current		Check the motor specification table or self-learning
[02][04]	Set Motor line resistance Rs		Check the motor specification table or self-learning
[02][05]	Set Motor line Inductance Ld		Check the motor specification table or self-learning
[02][07]	Set Motor Counter EMF krpm/v	0-4095	Check the motor specification table or self-learning
[02][12]	Check Motor encoder RT angle		Motor Rotor RT position
[02][10]	Motor parameter identify 1.Resistor inductance 2.Encoder zero position finding 3.Inertia identify 4.one step for 1-3	0-4	Use when self-learning
[02][18]	Check motor RT temperature		>80℃ will alarm
[03][11]	Check speed input voltage (0.00-10.00V)		The input voltage from PLC
[03][12]	Check pressure input voltage (0.00-10.00V)		The input voltage from PLC
[03][13]	Check response pressure (0-250 kg/cm2)		From the pressure sensor response
[03][14]	Set speed input start voltage (0.20)	0-10.00V	0.2
[03][15]	Set speed input max voltage (9.50)	0-10.0V	9.5V
[03][18]	Check drive RT temperature		>1200C will alarm
[05][01]	Set decompression speed	0.2-1.2	0.7
[05][06]	Set Pump displacement	10-200	As per the model
[05][11]	Set reverse max speed	0-500rpm	75 rpm
[06][00]	Set pressure loop P	0.5-2.5	1.5
[06][01]	Set pressure loop I	0.01-1.00	0.02
[06][05]	Set the hydraulic system response frequency	50-1000Hz	160
[06][16]	Speed input rising delay	0.01-10S	0.01S
[06][17]	Speed input fall delay	0.01-10S	0.01S
[06][18]	Pressure input rising delay	0.01-10S	0.01S
[06][19]	Pressure input fall delay	0.01-10S	0.01S