



# Guidance on the Transport of Mobility Aids

First Edition





## **Disclaimer Notice**

The information contained in this document is provided by the International Air Transport Association (IATA) for general information purposes only. Nothing contained in this document constitutes a recommendation, endorsement or preference by IATA. Different jurisdictions have varying (consumer and other) laws, regulations and procedures. No user of the guidance should act or rely on any information from this document without seeking the advice of a competent legal counsel. This guidance is not intended to substitute for any business' individual decision.

## **Limitation of liability**

IATA does not assume, and expressly disclaims, any liability to any person(s) or entities for any loss or damage caused by errors or omissions in this document or misinterpretation of the contents hereof. IATA expressly disclaims any liability to any person or entity in respect of anything done or omitted, and the consequences of anything done or omitted, by any such person or entity in reliance on the contents of this document. This document was produced by IATA. IATA asserts the right to control the distribution and use of the content.

For more information, please contact: IATA at [gia@iata.org](mailto:gia@iata.org)

## **Table of Contents**



<b>Introduction</b> .....	<b>4</b>
<b>Acknowledgements</b> .....	<b>5</b>
<b>Chapter 1 – Definitions and Special Service Request Codes</b> .....	<b>6</b>
1.1 Definitions .....	6
1.2 Special Service Request Codes .....	8
<b>Chapter 2 – Standardization</b> .....	<b>9</b>
2.1 Mobility Aid Passport .....	10
2.2 Mobility Aid Tag .....	11
2.2.1 Content of the Mobility Aid Tag .....	11
2.2.2 Process .....	12
2.3 Passenger Communication .....	13
<b>Chapter 3 – Booking and Airline Information Requirements</b> .....	<b>14</b>
3.1 Mobility Aid Handling and Passenger Assistance .....	14
3.2 Seat Assignment .....	14
3.3 Airlines Website Information .....	15
<b>Chapter 4 – Handing Over Mobility Aids for Travel</b> .....	<b>16</b>
4.1 General .....	16
4.2 Check-in of the Mobility Aid to be stored in the Cargo Compartment of the aircraft .....	16
<b>Chapter 5 – Boarding</b> .....	<b>17</b>
5.1 Boarding Procedures .....	17
5.2 On Board .....	18
<b>Chapter 6 – Connections and Point of Transfer</b> .....	<b>18</b>
7.1. Handling of Mobility Aids During Connections and Point of Transfer .....	19
7.2. Interline Connections .....	19
7.3. Assistance of the Passenger at Point of Transfer .....	19
<b>Chapter 7- Preparation, Loading and Securing of Mobility Aids into the Cargo Compartment</b> .....	<b>19</b>
8.1. General Principles .....	19
8.2. Preparation of Mobility Aids for Air Travel .....	20
8.3. Transferring Mobility Aids from Check-in /Gate to the Ramp .....	23
8.4. Loading and Securing of Mobility Aids .....	23
8.5. Containerized Mobility Aids .....	24
8.6. Securing the Mobility Aid in an Aircraft Container .....	24
8.7. Securing the Mobility Aid on an Aircraft Pallet .....	26
8.8. Bulk-Loaded Mobility Aid .....	26
8.9. Securing the Mobility Aid with Straps .....	29
<b>Chapter 8. Reuniting Passengers with their Mobility Aid</b> .....	<b>31</b>
<b>Chapter 9: Irregular Operation (IROP)</b> .....	<b>32</b>
9.1 General Principles .....	32



<b>Chapter 10: Definition and Procedure in case of Mishandling of Mobility Aids .....</b>	<b>32</b>
<b>Chapter 11: Training .....</b>	<b>33</b>
<b>Appendix 1 – Aircraft Cargo Door Dimensions.....</b>	<b>35</b>
<b>Boeing - Cargo door dimensions - single aisle aircraft .....</b>	<b>35</b>
<b>Airbus cargo door dimensions.....</b>	<b>35</b>
<b>Appendix 2 – RESNA Air Travel Configuration Card .....</b>	<b>38</b>
<b>Appendix 3 - Job Aids General Principles .....</b>	<b>45</b>
Job Aid number 1- Getting familiar with the Mobility Aid .....	45
Job Aid number 2- Placing the Mobility Aid into Air Travel Configuration .....	46
Job Aid number 3- Bulk Loading and Unloading at the Ramp .....	48
Job Aid number 4 - Containerized Loading at the Ramp .....	50
<b>Appendix 4- Areas for Future Consideration .....</b>	<b>52</b>
The Intersection of Air Travel and Assistive Technology is a Dynamic Environment.....	52
<b>Appendix 5 - Areas for further refinement .....</b>	<b>52</b>
Quality Assurance (QA) Audits.....	52
Using Specialized equipment, "Loading Plates" on Belt Loaders.....	53
Mobility aid transfer cart .....	54
Delay Handling .....	55
Safety Time Out .....	55
Storage of Straps in Aircraft or Cargo Compartment .....	55
Photograph of Secured Mobility Aid (Bulk Loading) .....	56
Photograph of Secured Mobility Aid .....	56
Passenger Communication .....	56
Coordination Between Air Carriers and Airports .....	56
Innovation to Prevent the Mobility Aid from Rolling Backwards on a Belt Loader.....	56
Identify Actual and Real-World dimensions for Aircraft Cargo Door Dimensions .....	56
<b>References.....</b>	<b>57</b>
<b>Acronyms .....</b>	<b>57</b>

## Introduction

The safe handling of mobility aids including wheelchairs has been identified as a key topic to advance air travel accessibility. Some individuals who use a mobility aid (particularly a battery-powered wheelchair or scooter), may be



reluctant to travel by air due to concerns of damage to their mobility aid, difficulties in stowing the aid safely in the cargo compartment, or delays associated with the return of the mobility aid to the passenger.

To face these issues, in 2021, IATA launched a global Mobility Aids Action Group (MAAG) to examine and improve the transport journey of mobility aids, including wheelchairs and scooters, with the objective of improving the handling of this vital equipment for passengers with disabilities.

Uniquely, the Action Group brings together the full range of stakeholders involved in this area, including accessibility organizations, airlines, ground service providers, airports, state regulators, academia and mobility aid manufacturers.

This guidance is published with the objective of addressing the issues identified and where feasible, improving the safe transportation of mobility aids. This in turn will reduce the risk of damage and breakage, through process improvements, the development of new tools, training, standardization requirements of these items across the industry, and design improvements for mobility aids.

The guidance reflects the best current practice available, as of its drafting, to address the challenges inherent in facilitating air travel for passengers utilizing a variety of mobility aids. It will continue to be revised and expanded as iterative practice improvements become possible and are developed into future standards.

Closing identified gaps will continue to present the air transportation industry with new challenges and opportunities. As the mobility-aid technology and airlines' operational environments continue to evolve, IATA and its airline members are committed to supporting the development of best handling practices in furtherance of the MAAG vision of making air travel with mobility aids as seamless as possible for all customers.

This guidance is intended as reference material to facilitate the safe transportation of mobility aids and thereby support travel by passengers that rely on these aids. It is not intended to be definitive and readers of the guidance should always have regard to applicable law, regulations and procedures that may apply in their jurisdiction or place of operations.

## Acknowledgements

This IATA Guidance on the Transport of Mobility Aids has been developed by the MAAG, which is comprised of airlines, airport, industry association, disability rights group members, handling agents, mobility aids manufacturers as well as government representatives and research association. These members have contributed to the making of this manual with hard work.

- ✓ **Airlines:** Aerolineas Argentina, Air Canada, Air New Zealand, Alaska Airline, British Airways, Delta, flydubai, ITA, United Airlines
- ✓ **Airports:** Aena, Amsterdam Schiphol Airport, Cincinnati / Northern Kentucky International Airport.
- ✓ **Accessibility Organizations:** Able Move, Access Israel, Beneficial Design, Open Doors, Paralyzed Veterans of America, Reduced Mobility Rights, Rehabilitation Engineering and Assistive Technology Society of North America (RESNA)
- ✓ **Aircraft Manufacturers:** Airbus, Boeing
- ✓ **Handling Agents:** Acciona, Celebi, dnata
- ✓ **Industry Associations:** Airlines for America (A4A), Airports Council International (ACI) World
- ✓ **Mobility Aids Manufacturers:** Invacare, Permobil, Sunrise Medical,
- ✓ **Regulators:** Canadian Transportation Agency, Transport Canada
- ✓ **Research Associations:** National Research Council Canada



A special thanks goes to Kerianne Wilson (AC), John Kirn (UA), Eric Lipp (ODO), Ray Prentice and Peter Axelson (RESNA) for their time, their dedication and passion to support the compilation of this guidance material.

# Chapter 1 – Definitions and Special Service Request Codes

## 1.1 Definitions

**Accessibility** - The term accessibility is often used when speaking of persons with disabilities and their right of access, enabling the use of assistive technology so that they can do what they need to do in a similar amount of time and effort as someone that does not have a disability.

**Air Travel Configuration Card:** A card including visual images, illustrations or diagrams of the mobility device configured for air travel, provided by the passengers to the airline for their personal mobility aid that will be transported on an aircraft. The air travel configuration card was designed by RESNA<sup>1</sup> and will be provided by the mobility aid manufacturer, where available.

**Airline Operator:** An airline operator is the ground handler appointed by the airline to handle the operations on their behalf.

**Ambulift:** An ambulift is a medical high loader or high lifter, also called ambulance lift or ambilift, used as a boarding vehicle for passengers with disabilities and reduced mobility (PRM), mainly people using wheelchairs (WCHC) or elder people with difficulties in climbing stairs.

**Cargo straps:** A Basic tie-down unit consisting of flat woven textile webbing (one fixed end and one adjustable end), one tensioning device and two end fittings, used for restraint of cargo on board civil transport aircraft (ref. [ISO](#))

**Dangerous Goods** - Articles or substances which are capable of posing a hazard to health, safety, property or the environment and which are shown in the list of dangerous goods in the IATA DGR or which are classified according to the DGR.

**Dry Batteries** - Sealed, non-vented batteries contain zinc salts and other solids or may be of the nickel cadmium type or other combinations of metals. Examples of such batteries are alkali-manganese, zinc-carbon, nickel-metal hydride (NiMh) and nickel-cadmium (NiCad) batteries.

**Lithium-ion batteries** (sometimes abbreviated Li-ion batteries) - A type of secondary (rechargeable) battery where the lithium is only present in an ionic form in the electrolyte. Also included within the category of lithium-ion batteries are lithium polymer batteries. Lithium-ion batteries are generally used to power devices such as mobile telephones, laptop computers, and e-bikes.

**Load Distribution Message:** In the IATA Airport Handling Manual procedures, messages are sent to communicate with the transit station to describe the cargo load. The Load Distribution Message (LDM) is brief message detailing the load distribution in the aircraft.

---

<sup>1</sup> Rehabilitation Engineering and Assistive Technology Society of North America. RESNA is a standards organization that writes standards for assistive technology for mobility aids.





**Mobility Aid Passport:** A mobility aid passport is intended as a static set of information that belongs to the mobility aid and connects the mobility aid to its owner. The passport should be provided by the mobility aids manufacturer.

**Mobility Aid Tag:** A physical tag that is attached to the mobility aid to provide airlines with information necessary to safely transport mobility aids. The tag is generally provided and completed by the airlines but can originate from the passenger or a disability organization.

**Neutral:** (as it relates to mobility aids drive system): Placing the mobility aid into freewheel mode so the drive mechanism and/or brakes are disengaged, and the mobility aid can be manually pushed / moved.

**Non-spillable battery** - have an absorbed electrolyte (absorbed glass mat (AGM), gel battery, gel cell, sealed lead-acid (SLS), dry and dry cell) and do not leak any electrolyte or liquid even if the battery case is ruptured or cracked. The batteries must be capable of passing certain vibration and pressure differential tests.

**Passengers with Disabilities (PWD)<sup>2</sup>:** Disability is a term used to refer to individual functioning, including physical impairment, but also used for sensory impairment, cognitive impairment, intellectual impairment, mental illness, neurodevelopmental conditions and various types of chronic disease. Non-visible disabilities are defined as disabilities that are not immediately apparent. Passengers with disabilities include, but is not limited to, passengers with the following types of disabilities and temporary or permanent conditions:

- People with reduced mobility (PRM).
- People who are blind or have low vision.
- People who are deaf or hard of hearing.
- People with speech disabilities.
- People with intellectual and developmental disabilities.
- People with cognitive disabilities, including people with mental health conditions.
- People with an illness and are authorized to travel by medical authorities, but whose mobility is impaired due to pathology in progress; and people unable to stand or walk due to injury.

**Passengers with Reduced Mobility (PRM)<sup>3</sup>:** The definition of passengers with reduced mobility is understood to be any person whose mobility is reduced due to physical disability (locomotory or sensory) intellectual impairment, age, illness or any other cause of disability and who needs some degree of special accommodation or assistance over and above that provided to other passengers.

This requirement will become apparent from special requests made by the passengers and/or their family or by a medical authority or reported by airline personnel or industry-associated persons (travel agents, etc.). The level of assistance required by the airport and/or the air carriers can vary depending on the different needs that people have when traveling by air.

---

<sup>2</sup> IATA Resolution 700 - Acceptance and Carriage of Passengers With Disabilities Requiring Assistance

<sup>3</sup> Ibid



**Personal Care Attendant<sup>4</sup>:** A Personal Care Attendant is a person who assists PWDs with their personal needs during the flight (e.g., eating, use of lavatory facilities, taking medication, etc.). The Personal Care Attendant provides assistance which cabin crew cannot provide.

**Resolution** – Resolutions are binding for IATA member airlines. Adopting, changing or rescinding a resolution requires unanimous support from all airlines participating in the conference. A developed by owning group, endorsed by Board and adopted by Conference with unanimous support from airlines, binding on all members

**Recommended Practice** - developed by owning group, endorsed by Board and adopted by Conference with two-third majority support from airlines, provides guidance to members.

**Safety Assistant<sup>5</sup>:** A Safety Assistant is a person that shall be at least 16 years old (unless local legislation establishes a different minimum age) who is physically and mentally able and willing to assume the responsibility for the PWD in case of an emergency.

**Spillable battery** – consist of a series of metal plates immersed in an electrolyte. The electrolyte is a corrosive liquid such as dilute sulphuric acid. Spillable batteries will leak the corrosive electrolyte if not maintained in an upright condition throughout transport, including loading and unloading.

**Unit Load Device (ULD):** An aircraft ULD is a device for grouping and restraining cargo, mail and baggage for air transport. It is either an aircraft container or a combination of an aircraft pallet and an aircraft pallet net. The design, testing, manufacturing, operations as well as maintenance and repair of the unit load device are all subject to the safety and airworthiness requirements from the civil aviation authorities. For more information visit the IATA [website](#)

## 1.2 Special Service Request Codes

The IATA Special Service Request (SSR) codes are the standard method of communication for airline and airport personnel to know what assistance a passenger will require. When traveling with a mobility aid, it is especially critical for a passenger to share that information at the time of booking to allow an airline to prepare their operations.

It is recommended that the booking airline or travel agent obtain the mobility aid specifications (e.g. including the accessories, the height, width, weight, battery type and for lithium-ion batteries the Watt-hour rating and if it is easily removable) and make all efforts to validate that the aircraft scheduled to operate the flights in the itinerary can accommodate the mobility aid.

As general guidance, the carriage of the passenger battery-powered mobility aid must be compliant with IATA Dangerous Goods Regulations (DGR) subsection 2.3.2.2 to 2.3.2.4

The SSR information should be made available to all frontline personnel throughout the passenger's journey. Airlines should ensure that the Passenger Name Record <sup>6</sup>(PNR) contains accurate special service codes (SSR) as mandated by Resolution 700, specifically:

---

<sup>4</sup> Ibid

<sup>5</sup> Ibid

<sup>6</sup> A Passenger Name Record (PNR), in the air transport industry, is the generic name given to records created by aircraft operators or their authorized agents for each journey booked by or on behalf of any passenger. The data are used by operators for their own commercial and operational purposes in providing air transportation services. Industry standards related to PNR creation are detailed in IATA's Passenger Services Conference Resolutions Manual and in the ATA/IATA Reservations Interline Message Procedures — Passenger (AIRIMP).





- **WCHR** (Wheelchair—R for Ramp)—passenger can ascend/descend steps and make own way to/from cabin seat but requires wheelchair for distance to/from aircraft, i.e. across ramp, finger dock or to mobile lounge as applicable.
- **WCHS** (Wheelchair—S for Steps)—passenger cannot ascend/descend steps, but is able to make own way to/from cabin seat; requires wheelchair for distance to/from aircraft or mobile lounge and must be carried up/down steps.
- **WCHC** (Wheelchair—C for Cabin Seat)—passenger completely immobile; requires wheelchair to/from aircraft/mobile lounge and must be carried up/down steps and to/from cabin seat.
- **WCOB** (on-board wheelchair needed) - Airlines may require advance notice if WCOB (on-board wheelchair provided by the airline) is needed. This code could be used in conjunction with one of the SSR codes that identify the type of assistance needed.

When the passenger is traveling with their own wheelchair the following wheelchair equipment codes shall be used:

- **WCBD** (Non-spillable, nickel-metal hydride or dry battery)—to be transported by a passenger which will require advance notification and may require preparation/(dis)assembly. Weight and dimensions may be specified. Wheelchair and battery must be claimed and rechecked at each interline transfer point (by bilateral agreement).
- **WCBW** (Wet cell battery)—to be transported by a passenger which will require advance notification and may require preparation/(dis)assembly. Weight and dimensions should be specified. Wheelchair and battery must be claimed and rechecked at each interline transfer point (by bilateral agreement).
- **WCMP** (Manual power)—to be transported by a passenger. Weight and dimensions should be specified (by bilateral agreement). It is recommended that the code WCMP is reserved for manual chairs without power assistive device.

Note: Many manual chairs are fitted with a power assist device. A power assist device is a motorized accessory or power adds-ons that can be attached to a manual wheelchair, transforming a manual wheelchair into a power assisted device. It allows a wheelchair user to propel with less energy expenditure. Also referred to as a power drive, consists of a drive unit made to attach to a wheelchair, and may also come with a control unit.

- **WCLB** (Lithium-ion battery)—to be transported by a passenger which will require advance notification/preparation. Weight and dimensions should be specified. Wheelchair and battery must be claimed and rechecked at each interline transfer point (by bilateral agreement).

## Chapter 2 – Standardization

The Mobility Aids Action Group has worked with members of the RESNA<sup>7</sup> Assistive Technology for Air Travel Standards Committee<sup>8</sup> and with associations who represent the mobility aid manufacturers and rehabilitation

---

<sup>7</sup> Rehabilitation Engineering and Assistive Technology Society of North America. RESNA is a standards organization that writes standards for assistive technology for mobility aids.

<sup>8</sup> This committee developed a standard for Air Travel Information Cards for Mobility Aids to communicate how Mobility Aids should be configured for storage in aircraft and how they should be configured for use. The standard also includes a section on specifications for Mobility Aid features that are designed to reduce the likelihood of damage that can occur when stored in the cargo hold of all aircraft, particularly those aircraft with shorter height baggage doors which make it more difficult to accommodate some powered Mobility Aids.



professionals to emphasize the need to design and market mobility aids that are transportable by air and meet the needs of persons with disabilities.

## 2.1 Mobility Aid Passport

A Mobility Aid Passport is intended as a static set of information that belongs to the mobility aid and connects the mobility aid to its owner. The idea of a mobility aid passport is not new to the mobility aid industry. Public transportation providers throughout Great Britain have adopted a full British Standard in 2013. The Passport is defined in the BS standard such as

“2.13 passport-document attached to a wheelchair, containing key instructions and information regarding provisions for the needs of an individual and their wheelchair in transport<sup>9</sup>

The MAAG discussed the need for a “passport” for the mobility aid that contains specifications on the mobility aid such as the dimensions and any special instructions for safe handling. The MAAG recommends that this mobility aid passport is developed by mobility aid manufacturers, rehabilitation professionals and after-market equipment providers. Specifically, manufacturers and rehabilitation professionals should be responsible for basic elements and the after-market vendors should be responsible for updates to ensure the accuracy of the passport content.

Every mobility aid manufacturer and thereafter point of service should ensure that mobility aids are equipped with the following key information:

- Type – manual or battery-powered
- If manual, specify if there is a wheel lock or brake.
- If the mobility aid is battery-powered, it should contain the following information:
  - type of battery
  - If lithium-ion, the Watt-hour rating of the battery(ies) and whether the batteries must be removed<sup>10</sup>
  - Location of the mechanism to put the mobility aid into neutral
  - Specify if there is a power isolation switch
  - Method to disconnect the battery
- Weight of the mobility aid
- Dimensions of the aid (L x W x H) in its air travel configuration at its lowest height<sup>11</sup> (when all detachable parts are removed, and the mobility aid is ready to be loaded into the cargo compartment of the aircraft)
- Specify if the back rest needs to be folded down or removed
- Components that can be removed for transport/stowage, such as:
  - Seat cushion
  - Back support
  - Arm Support
  - Head Support
  - Foot Support
  - Controls (joystick, etc)
  - Wheels
  - Side guards

---

<sup>9</sup> <https://otc-cta.gc.ca/eng/publication/mobility-aids-and-air-travel-final-report>

<sup>10</sup> It is very often that, if the sufficient protection cannot be provided to the batteries, and that they cannot be securely attached to the mobility aid, the manufacturer would specify that the batteries must be removed.

<sup>11</sup> It is defined as the smallest overall dimensions the dimension of the mobility aid that fits through the cargo door i.e with the seat back lowered and without removable components



- Belts or straps
- QR code from the manufacturer where further details can be obtained specific to the aid, such as:
  - Detailed technical specifications from the manufacturer.
  - User's manual.
  - Images of the aid can be viewed in various configurations including an air travel configuration (ready to use; ready to transport with folded parts)

The format of the so-called Mobility Aid Passport could be both physical and electronic format so that relevant information can be transmitted by the passenger to airlines upon booking, or otherwise preserved as a permanent file in an airline's system, subject to agreement by the passenger and in compliance with data privacy regulations.

**RECOMMENDATION:** It is recommended that the Mobility Aid Passport be aligned with the RESNA AT-1 Section 4 Annex B Air Travel Configuration Card and the RESNA standard AT-1<sup>12</sup> shown in Appendix.

## 2.2 Mobility Aid Tag

Airlines should consider using a Mobility Aid Tag to facilitate communication between the passenger with disabilities and the ground staff responsible for handling and loading the mobility aid on the day of travel.

### 2.2.1 Content of the Mobility Aid Tag

Pending the development of an electronic mobility aid tag, it is recommended that airlines provide a manual mobility aid tag to facilitate safe handling of the mobility aid. This tag would be used only for checked mobility aids.

Suggested information to include on the mobility aid tag is listed below:

- Passenger Name
- Contact details (e.g. phone number and/or email)
- Unique Record Locator
- Passenger itinerary
- Mobility aid battery type
- Mobility aid make and model
- Dimensions of the mobility aid (e.g. height, width and weight)
- Where the passenger expects to have the mobility aid delivered to them (e.g. airlines can use different colour tags to identify where the customer prefers the mobility aid to be returned – for the single trip)
- Removable items stowed in the cabin or in cargo hold (remove only what passengers agree to remove at the passenger discretion / to be hand-written at the time of flight)
- Prior damage to the mobility aid (to be hand-written in or recorded in the system where possible and at the gate/ photographic evidence)
- Include some space for free-flow text to record adjustments made to the mobility aid to stow it (example: folded items; joystick still attached but put in seat; disconnected wires; etc.)
- Receipt for the passenger with bar code, similar to all other bag tags (when digitalized)

---

<sup>12</sup> The RESNA AT-1 provides information for the design of Mobility Devices including powered wheelchairs, powered scooters, power assist wheelchairs, and manual wheelchairs that have features that are specifically designed to be easier to stow and transport by air carriers.



## 2.2.2 Process

Airlines are recommended to affix the print-out of the mobility aid tag order to:

- minimize damage to the mobility aid;
- ensure the mobility aid is quickly identified and travels safely with the passenger;
- facilitate the communication with those handling the aid that it is coming, so that they may prepare; and
- speed up the delivery process during transfers and at destination.

If the mobility aid tag includes a bar code for scanning into the baggage system, airlines should associate the mobility aid tag reference to the passenger's PNR<sup>13</sup>. Airlines should make all efforts to ensure that a mobility aid tag referenced in a PNR facilitates tracking of the mobility aid when it is loaded and unloaded from the aircraft.

The MAAG recommends that the back of the tag should be a unique, inclusive, worldwide recognizable design/label. For example, the content of the tag could be printed on a card that is bright neon colour to draw attention and reflect inclusivity.

**RECOMMENDATION:** The MAAG recommends that IATA create an accessible standard electronic mobility aid tag and supports its rollout and use across the industry. A barcode for scanning the aid into the baggage system should be included on the e-mobility aid tag so that a separate electronic tag that connects to the baggage tag system would not be necessary.

---

<sup>13</sup> Passenger Name Record

Customer Name / Nom du client \_\_\_\_\_

Brand / Marque \_\_\_\_\_

Model / Modèle \_\_\_\_\_

Date \_\_\_\_\_

Flight # / N° de vol \_\_\_\_\_ Destination \_\_\_\_\_ Seat # / N° de place \_\_\_\_\_

↑ Flight # / N° de vol \_\_\_\_\_ Destination \_\_\_\_\_ Seat # / N° de place \_\_\_\_\_

↑ Flight # / N° de vol \_\_\_\_\_ Destination \_\_\_\_\_ Seat # / N° de place \_\_\_\_\_

**DELIVERY TO CUSTOMER  
LIVRAISON AU CLIENT**  
(Choose one / Choisir une option)

Gate at final destination  
Porte d'embarquement à la destination finale

Gate at each segment  
Porte d'embarquement à chaque segment

Baggage claim at final destination  
Zone de retrait des bagages à la destination finale

**MOBILITY AID  
APPAREIL D'AIDE À LA MOBILITÉ**

Weight / Poids \_\_\_\_\_ kg  lbs   
(with battery / avec batterie)

Type

WCLB Lithium-ion battery  
Batterie au lithium-ion \_\_\_\_\_ Wh  
Lithium battery pack removed and carried in the cabin  
Bloc batterie au lithium retirée et transportée en cabine

WCBD Gel/Non-spillable  
Batterie non versable

WCBW Wet cell battery  
Batterie versable

WCMP Manual  
Manuel

**Power Source Disconnection  
Débranchement de la source d'alimentation**

Ignition switch  
Interrupteur d'allumage

Disconnected battery  
Batterie débranchée

Instructions / Marche à suivre

\_\_\_\_\_

\_\_\_\_\_

\_\_\_\_\_

\_\_\_\_\_

\_\_\_\_\_

\_\_\_\_\_

\_\_\_\_\_

\_\_\_\_\_

\_\_\_\_\_

\_\_\_\_\_

**Stowage and prior damage  
Rangement et dommage antérieur**

	STOWED IN CABIN RANGÉ DANS LA CABINE	CARGO CARGO	PRIOR DAMAGE DOMMAGE ANTÉRIEUR
Head support Soutien pour la tête	<input type="checkbox"/>	<input type="checkbox"/>	<input type="checkbox"/>
Arm support Soutien pour les bras	<input type="checkbox"/>	<input type="checkbox"/>	<input type="checkbox"/>
Foot support Soutien pour les pieds	<input type="checkbox"/>	<input type="checkbox"/>	<input type="checkbox"/>
Control (Joystick, etc.) Contrôle (Manette, etc.)	<input type="checkbox"/>	<input type="checkbox"/>	<input type="checkbox"/>
Belts/Straps Ceintures/courroies	<input type="checkbox"/>	<input type="checkbox"/>	<input type="checkbox"/>
Wheels Roues	<input type="checkbox"/>	<input type="checkbox"/>	<input type="checkbox"/>
Seat cushion Coussin du siège	<input type="checkbox"/>	<input type="checkbox"/>	<input type="checkbox"/>
Frame Cadre	<input type="checkbox"/>	<input type="checkbox"/>	<input type="checkbox"/>
Seat side guards Protecteurs latéraux du siège	<input type="checkbox"/>	<input type="checkbox"/>	<input type="checkbox"/>
Assembly tools Outils d'assemblage	<input type="checkbox"/>	<input type="checkbox"/>	<input type="checkbox"/>
Total	_____		

Customer signature / Signature du client \_\_\_\_\_

ACF515M (2020-05)

This is an example of design of mobility aid tags/labels based on existing practices. Credit: Air Canada

## 2.3 Passenger Communication

Airlines should develop a toolkit for passengers traveling with mobility aids, so that passengers know what to expect, what information they should provide and why airlines request certain information. This should include instructions for airlines to facilitate the transportation of their mobility aid. Once developed, this toolkit can be made available to passengers through the airline's website as well as within the disability community on their organizational websites.

**RECOMMENDATION:** Airlines should develop a toolkit for passengers traveling with mobility aids, so that passengers know what to expect, what information they should provide in advance of travel and why airlines request certain information.



## Chapter 3 – Booking and Airline Information Requirements

Airlines and third-party booking agents should implement a consistent process to ensure that they capture at the time of booking, all relevant information regarding the passenger's needs. It is recommended that the information is captured in the PNR and contains at the minimum, information on the dimensions of the mobility aid and the type of battery. Passengers should be made aware of what information is needed from them during the booking time and the reason why this information is being requested.

### 3.1 Mobility Aid Handling and Passenger Assistance

Airlines and airport operators should ensure that the booking conforms with the information provided by the passenger and the operational requirements of the airlines, including:

- Sufficient time is allotted for connection both of the passenger and the mobility aid, which may need to be reassembled and delivered to the passenger at the connection point to facilitate their mobility in the airport, and subsequently disassembled and re-packaged for departure from the connection point.
- The size of the mobility aid in its air travel configuration adjusted to be as low as possible such that it fits through the cargo doors (if loaded in the cargo compartment) of the aircraft scheduled to operate on the passenger's entire journey, or, if not checked, that it can be stowed in the cabin. Booking agents should have access to aircraft dimension charts to validate this information at the time of booking.
- Information on the mobility aid should be collected in advance and communicated to airlines involved in the passenger's itinerary (weight, dimensions, battery type, if lithium-ion, the Watt hours and if it is easily removable- at a minimum). Airlines should consider asking passengers to provide photos together with other information to determine that the battery has to be removed. If the battery can be well protected and can be securely attached to the mobility aid, it may not be necessary to remove it.
- Booking parties (e.g. travel agents or airlines) should ensure that a process is in place so that their agents or the passenger, as the case may be, are aware of the need to contact the airlines involved in the passenger's journey to provide the information and validations identified above. Conversely, airlines should ensure that their booking path allows for the capture of this information, and for this information to be edited before travel.
- At the connection/point of transfer, airlines, airports and assistance providers should ensure that there is a clear procedure in place for ground staff to ensure that the mobility aid is delivered to the customer, if so requested, safely and without delay.

### 3.2 Seat Assignment

Passengers should have the ability, in the booking system or consequently in the follow-up with the airline to reserve the type of seat that best accommodate the individual's disability in compliance with the class of service and the appropriate safety rules. Government regulation or carrier safety policy concerning seating shall be observed.





### 3.3 Airlines Website Information

As general guidance, airlines should ensure that their website contains a dedicated area for special assistance that is easy to access, and that information is easy to understand. Airlines' website should provide, at the very least, the following information:

- Definition of assistance service.
- How to book the assistance service.
- Where feasible, safety and mobility aids space restriction.
- Seating allocation.
- Conditions under which a safety assistant is required.
- Medical equipment allowance, considerations, and restrictions.
- How to make a claim in the event a mobility aid is mishandled.
- Helpline telephone number.
- Key information that may be required in respect of a passenger's mobility aid, and when it should be provided, such as:
  1. For a manual wheelchair, the weight, dimensions (at its smallest, ready to load, length x width x height), and whether they intend to stow it in the cabin.
  2. For a battery- powered mobility aid: weight, battery type (if lithium ion, the Watt hours and whether the batteries must be removed<sup>14</sup>) and dimensions (at its lowest, ready to load, length x width x height).

Passengers traveling with a mobility aid should inform airlines as soon as possible about what component of the mobility aid should or could be removed (e.g. protruding or fragile parts that may be damaged during carriage or cannot fit through the cargo door) so that the information can be communicated to the ramp personnel at the airport.

Passengers should be ready to provide photos together with other information. This will help airlines to determine whether the battery has to be removed. If the battery can be well protected and can be securely attached to the mobility aid, it may not be necessary to remove it.

If information is not provided in advance, passengers should come to the airport prepared with written instructions and be ready to remove and pack separately as carry-on, any removable parts from their mobility aid to prevent loss or damage.

Airlines' website should inform passengers:

- To arrive in advance at the airport for the check-in procedures<sup>15</sup>.
- About the minimum connecting time for their flight – although passengers may or may not be imposed a longer connection, depending on local regulation, they should be advised that retrieving and transferring their mobility aid may take additional time and should consider possible alternatives to complete the itinerary.
- About the policy related to onboard wheelchairs
- About the cabin closet size; and

---

<sup>14</sup> It is very often that, if the sufficient protection cannot be provided to the batteries, and that they cannot be securely attached to the mobility aid, the manufacturer would specify that the batteries must be removed.

<sup>15</sup> Member airlines may request for passengers requiring specific assistance to check in early enough to allow time to provide the accommodations in a correct and timely manner without delaying the flight.



- About cargo compartment door dimensions and weight limitations per aircraft types that may prevent the transportation of certain mobility aids.

Wherever possible, airlines should ensure that passengers are able to request service assistance and advise the airline that they are traveling with a mobility aid, without having to call the airline. Airlines should confirm with the passenger that their assistance needs have been recorded and the fact that they are traveling with their own mobility aid is included in their reservation prior to travel.

## Chapter 4 – Handing Over Mobility Aids for Travel

### 4.1 General

Each mobility aid is unique and often includes custom features specific to the user, providing the greatest possible comfort and scope for maximum mobility. Transferring the passenger to an airport wheelchair may cause discomfort or unintended injury, which can be aggravated if the passenger is obliged to stay in the chair for any length of time.

These are important factors which airlines, airports and third-party assistance providers should consider.

Accordingly, a mobility aid that is to be transported in the cargo compartment of the aircraft can be handed over by the passenger at check-in, at the boarding gate or where feasible at the aircraft door. If the mobility aid is handed over at check-in, passengers should be assisted through the terminal to the boarding gate. Not all mobility aids need to be loaded in the cargo compartment. Passengers traveling with their own collapsible mobility aid may request it to be carried in the passenger cabin where storage facilities are available.

Such requests will be accommodated on a "first come first served" basis. Where such facilities do not exist, the mobility aid will be loaded in the cargo compartment of the aircraft where it is easily accessible for timely return to the passenger. Every attempt should be made to allow the storage of other mobility aids such as canes, walkers, and crutches in the cabin in the event they are needed in flight.

### 4.2 Check-in of the Mobility Aid to Be Transported in the Cargo Compartment of the Aircraft

Passengers who intend to check in their mobility aid should be given the option of using an airport wheelchair. Where the airport infrastructure allows for it, if the passengers prefer to use their mobility aid within the airport, they should normally be permitted to use it up to the aircraft door. Whichever option is preferred by the passenger, their choice should be communicated to airport assistance providers and respected.

When a mobility aid is tendered for transport in the cargo compartment of the aircraft, airlines should ensure that mobility aid information and passenger assistance requirements are documented in the PNR and that the appropriate SSR codes are recorded. If the airline realises that relevant information related to the mobility aid is missing, then every effort should be made to add it without delay, to allow appropriate teams for a proper planning and loading process.



Relevant information should include weight, dimensions, and battery type of the mobility aid (for lithium battery, the Watt-hour rating and if the battery should be removed<sup>16</sup>). If the above information is already present, then the airline should validate that the SSR code is correct, and that the wheelchair information is made available to the appropriate teams.

Airlines should ensure that the information received from the passenger is transmitted to all stakeholders involved in the passenger's journey and the handling of the mobility aid (e.g. from travel agents to airline reservation systems, to airport agents, frontline personnel and handlers at all airports, including departing, connecting and destination airports).

The information should be retrieved and transmitted well in advance to allow proper planning for equipment and the ground staff needed to assist the passenger and the handling of the mobility aid. Information about the passenger's needs and the location of the mobility aid in the cargo compartment of the aircraft should be made available to the cabin crew and the captain in command.

Ground staff should record the passenger preference for delivery and return of their mobility aid on arrival, whether this should be at the gate or the baggage claim area. The default should be to accompany the passenger seated on their mobility aid up to the gate and where feasible at the aircraft door during the boarding process, however, the passenger should have the ability to request a return at the baggage claim area upon arrival.

Whenever a mobility aid will be stored and secured in the cargo compartment of the aircraft the ground staff should complete the mobility aid tag, as described in Chapter 2.

Wherever an electronic mobility aid tag is used, it should be associated with the PNR and a mechanism should be in place so that the mobility aid can be tracked at any time of the travel. Whether the passenger is checking their mobility aid at the check-in desk or the gate, the ground staff should ensure that components removed from the mobility aid are documented on the mobility aid tag and stowed in the cabin of the operating aircraft.

Airlines, airports, assistance service providers and handlers should have specific and clear procedures for each gate or terminal for the movement of mobility aids between the gate and the ramp, including the responsible person for moving the mobility aid.

To the extent possible, mobility aids other than battery-powered aids should be stored in the cabin. Manual wheelchairs that cannot be collapsed to fit in the cabin should be stored in the cargo compartment of the aircraft but components that can be removed should be returned to the passenger and stored in the cabin to reduce the potential for damage.

## Chapter 5 – Boarding

### 5.1 Boarding Procedures

The presence of passengers with disabilities, their personal care attendants, safety assistants and any arrangements made for them while on board, should always be referred to the appropriate crew members (e.g., the pilot-in-command or senior cabin crew member). Passengers with disabilities and their personal care attendants and

---

<sup>16</sup> Airlines should consider asking passengers to provide photos together with other information to determine that the battery has to be removed. If the battery can be well protected and can be securely attached to the mobility aid, it may not be necessary to remove it.



safety assistants should be offered pre-boarding opportunities. If passengers for any reason have to be offloaded, the highest possible priority for transportation should be given to passengers with disabilities, as well as to their personal care attendants and safety assistants<sup>17</sup>.

Passengers who require a lift and transfer to board the plane should be allowed to pre-board with sufficient time before general boarding begins to provide privacy and dignity for the cabin transfer process. This process should also be applied to those passengers who will board via aisle chairs.

Airlines and assistance providers should have specialized mobility teams that are specifically trained to provide the lift to the passenger and assistance with the transfer from the aisle chair to the seat.

Where the aircraft is on a remote stand or boarding bridges are not available or not in use, mobility aids users will generally have to be transferred out of their mobility aid on the ground outside the aircraft, or in the vehicle that has transported them to the aircraft. In this case, different methods to board the aircraft should be used, such as:

- scissor elevator or ambulift;
- stair climber or stair elevator;
- mobile passenger boarding ramp, where allowed by regulation.

Airports should ensure they have a variety of appropriate equipment to board passengers, such as ramps, lifts and ambulifts, where jet bridges are not available. Where equipment is available, airlines and airports should ensure that assistance teams are alerted, and the mobility aid loading equipment is made available in time for boarding. A standard procedure should be designed to ensure all equipment at the airport and onboard (e.g. aisle wheelchairs) are inspected and kept in usable, clean and dignified condition at all times.

Depending on local regulations, airlines and airports should coordinate to make available to the transfer teams, lifting slings, transfer boards, and transfer belts as necessary to ensure a safe and dignified lift for every passenger. Passengers should also be allowed to bring their own mobility aids that suit their personal needs for transferring as not all equipment and slings provided by airports and airlines are suitable for individuals.

## 5.2 On Board

Upon boarding, passengers should be assisted with storing their carry-on baggage. The cabin crew should provide passengers with an individualized briefing on the safety features of the aircraft as needed and as required by local regulations. The cabin crew should not be expected to assist within the lavatory, with eating or with taking medication.

## Chapter 6 – Connections and Point of Transfer

Wheelchairs and other mobility aids checked in should, within the shortest possible time, be delivered as close as possible to the door of the aircraft or as requested by the passenger. However, this is based on the airport facilities, the connection time and the time needed to retrieve and re-load the mobility aid. Where the option is not available to the passenger, then the passenger should be made aware, as applicable and feasible, during the booking process if the passenger has communicated that she/he will travel with a mobility aid.

---

<sup>17</sup> IATA Resolution 700 – Acceptance and Carriage of Passengers with Disabilities Requiring Assistance



## 6.1. Handling of Mobility Aids During Connections and Point of Transfer

If at the time of booking, the passenger communicated that they would travel with their mobility aid, ground staff should make this information available and be ready to:

- Upon the arrival of the aircraft, return the mobility aid to the passenger upon disembarkation; and
- Upon the departure of the aircraft, load the mobility aid after the passenger's boarding.

## 6.2. Interline Connections

In the event that an interline connection is involved, the delivering airline will have completed its responsibility for assisting the passenger with disabilities when the passenger has been transferred to and accepted by the connecting airline. It is important that airline's ground staff and the airport assistance teams of the delivering/connecting airline communicate in a timely fashion with ramp teams about the mobility aid needing to be transported, including at a minimum, weight, dimensions, and battery type.

In the event the mobility aid cannot be returned to the passenger during the connection, the handling teams of the delivering or connecting airlines should, to the extent possible, share the ground equipment with the delivering and connecting carrier or coordinate to share knowledge about the best handling and supporting approach.

## 6.3. Assistance of the Passenger at Point of Transfer

Should the connecting airline staff, airport or assistance service provider staff not be present, the delivering airline personnel should make whatever arrangements that are necessary for the care and welfare of the passenger, until such time that it can ensure a seamless handover.

If the mobility aid cannot be returned to the passenger at the transfer point, assistance service providers at the airport and the delivering/receiving carrier should coordinate to ensure that the passenger remains in an aisle chair for the least amount of time possible and is moved to an airport chair as soon as possible.

It is noted that for some individuals, airport chairs will not work if they do not have seat belts. The airport chair cannot be considered a safer option as it still does not provide the proper seating system for someone with a permanent disability such as a spinal cord injury.

# Chapter 7- Preparation, Loading and Securing of Mobility Aids into the Cargo Compartment

## 7.1. General Principles

Mobility aids should always be loaded as priority baggage and never be left behind. They should be last to be loaded into the aircraft and first be unloaded, to ensure passengers stay in their mobility aid as long as possible, and that the mobility aid is returned to the passenger as soon as feasible.

Airlines and service providers should ensure all parties involved are aware of who is in charge of moving the mobility aid between the aircraft door and the ramp.



It is recommended that when loading mobility aids in the air cargo compartment or aircraft ULD, airlines utilise stowage receptacles such as polyethylene bags or cardboard cartons. This will help to prevent the loss of detachable parts or damage to the mobility aid or other baggage loaded with it. Wherever possible, detachable parts should be removed from the mobility aids and carried in the cabin with the passenger.

As stated in IATA Resolutions 700 and 745b, equipment required by passengers with disabilities in connection with their trip, if not carried in the passenger cabin, shall be loaded in the cargo compartment where it is easily accessible for timely return to the passenger at connection or destination points. Any such item must be properly identified and tagged and must always travel on the same aircraft with the passenger. Once loaded, wheelchairs and other mobility aids must be restrained and secured (e.g. using restraint straps) against the movement in the cargo compartment of the aircraft and must be safely loaded in a manner so that they are protected from being damaged by the movement of baggage, mail, or cargo. While it is important to secure the mobility aid from movement during transport, it is equally important that the restraint condition is observed (e.g. not damaging the mobility aids).

As general guidance, airports and airlines should partner to ensure that:

- Employees or contractors who handle mobility aids receive regular recurrent training, at least as often as required by international and local regulations.
- There are sufficient elevators or lifts for efficient movement of mobility aids between the gate and ramp; and
- There are sufficient wheelchair lifts to move aids from the ramp to the belt loader or directly into the cargo compartment.

## 7.2. Preparation of Mobility Aids for Air Travel

The ramp personnel should be notified as early as possible that the passenger is traveling with their own mobility aid so they can gather any necessary information and secure special equipment, such as mechanical lifts. They should collaborate and partner with the passenger, as this is the best way to reduce potential damage to the mobility aid.

It is important to note that mobility aids are not designed for being loaded and transported in the cargo compartments on their sides.

### **BEST PRACTICE:**

- ❖ Where feasible, any necessary information should be gathered electronically and transmitted to all relevant stakeholders.
- ❖ Airlines and airports should have a designated ramp personnel responsible for loading the mobility aid.
- ❖ Airlines and handlers should communicate closely with the passenger who knows their mobility aid well.
- ❖ Airlines should provide ramp personnel with a job aid to ensure that mobility aids are consistently handled safely and in accordance with carrier policy and procedure.

The following steps should be taken to prepare the mobility aid for air travel (e.g. placed in "air travel configuration") taking into account such factors as:

1. **Weight** – Verify mobility aid weight in air travel configuration and validate that it can be accommodated in the aircraft in accordance with carrier policy.
2. **Dimensions** – Verify maximum length, width, and height of mobility aid in air travel configuration in accordance with carrier policy. Mobility aid should be reduced in height as much as possible to allow the mobility aid to fit through cargo door.

The following diagrams provide some examples of air travel configuration.



### Example 1 - Removing joystick, headrest and footrest

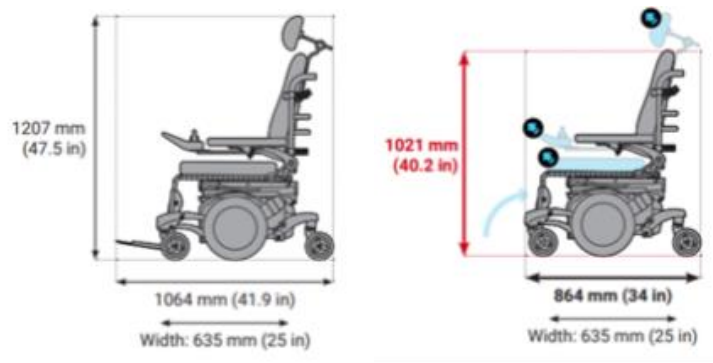

Credit: RESNA

### Example 2 - Lowering seat back

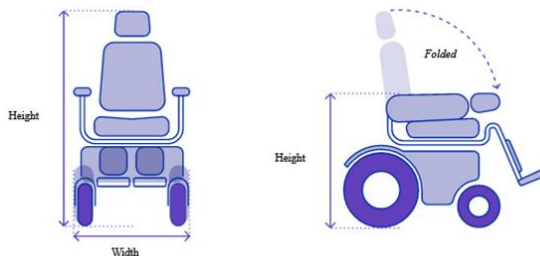

Credit: RESNA

#### **BEST PRACTICE:**

- ❖ Passengers should always be consulted regarding the orientation of their mobility aid for loading and transportation, in accordance with carrier policy.
- ❖ Tipping or laying mobility aids on their side is to be avoided, in accordance with carrier policy, as this increases the risk of damage to the mobility aid or injury to ground staff.
- ❖ The mobility aid should be moved through the cargo door in an upright position.

**CAUTION:** The mobility aid should be configured for its travel-ready configuration and positioned upright within the cargo compartment. When possible, ramp personnel should use passenger-provided tools or straps to help reduce the mobility aid dimensions.

3. **Power/Batteries (if applicable)**– Ensure batteries are safe for transport, in accordance with the current IATA Dangerous Goods Regulations (DGR 2.3.2.2 and 2.3.2.4) and the air carrier dangerous goods policy.
  - Use the power isolation switch or disconnect the quick-disconnect power cable to the battery.
  - Lithium-ion batteries that are adequately protected against damage by the design of the mobility aid and securely attached to the mobility aid are not required to be removed.
    - If the batteries are to be removed, they must meet the Watt-hour rating limit and must be stowed in the cabin.
  - If the mobility aid cannot be transported upright, spillable batteries must be removed and placed into containers approved for this purpose per the IATA Dangerous Goods Regulations and the carrier policy.



- Spare batteries must only be transported in accordance with the IATA Dangerous Goods Regulations and the carrier policy.
- Place the mobility aid in a freewheel mode (also known as disengaging the drive system).

**CAUTION:** If the drive system is not disengaged, considerable damage can occur to the internal components of the mobility aid when operators try to move it.

4. **Tags** – There may be up to 3 separate types of tags for a single mobility aid. This will include:
  - a. A customer provided tag or an Air Travel Information or Air Travel Configuration Card which contains specific mobility aid information
  - b. An airline provided string tag which may contain dangerous goods information and proper handling (the “mobility aid tag”).
  - c. A normal airline generated baggage tag (ABT) which contains the intended routing of the mobility aid.

If available, operators should complete the mobility aid tag in accordance with carrier policy and in consultation with passenger, as follows:

- Travel configuration mode (reducing the height of the mobility aid i.e., lowering the seat, removing, tilting or reclining the back support.
  - Unoccupied weight.
  - Removing parts that are fragile for transport in the cabin to prevent damage and loss.
  - Confirm the battery type and follow specific carrier policy.
  - Tie-down points/securing points.
  - Lift points.
  - Placing the mobility aid drive system into neutral.
5. **RESNA Air Travel Configuration Card** – If available, aircraft operators should consult the RESNA Air Travel Configuration Card on the mobility aid for additional information (See Appendix 2). Certain elements may include:
    - Dimensions of the Mobility Aid in the Air Travel and Use Configurations.
    - An illustration of the Mobility Aid in the Air Travel and Use Configurations.
    - Location of latch mechanisms to remove components.
    - Battery information – type, chemistry, number.
    - Battery isolation switch.
    - Drive disengagement mechanisms.
    - Lifting points.
    - Unoccupied weight.
    - Allowable tie-down points/ strapping locations.
    - Basic instructions for the ramp personnel.
  6. **Removal of Components** – To prevent loss or damage, passengers should be encouraged to remove detachable parts from the mobility aid and carry them into the cabin. Airline operators should:
    - Place components in carrier provided plastic bags if the passenger does not provide one.
    - The bag of components should be returned to the passengers, and only if that is inappropriate, then be tendered to the appropriate cabin crew members.



- The protection of the joystick is the highest priority. When designed for removal, removal of the joystick assembly is encouraged. Alternatively, passengers may provide a variety of methods to protect the joystick. Whenever feasible airlines should accommodate these requests.
- Other components of the mobility aid may be removed with passenger approval, including **but not limited to**:
  - seat and back cushions
  - other custom seating
  - head, arm, trunk and leg support that can be lost or damaged
- Any protective covering or wrapping the passenger provides should be applied when feasible.

#### BEST PRACTICE

- ❖ Remove the joystick, when the mobility aid is designed for removal, in consultation with the passenger.
- ❖ Protect the joystick, when the joystick is not designed for removal, or the passenger cannot be consulted.

7. **Return Location** – Air carriers should verify with passengers where they want their mobility aid be returned to them upon arrival or at a point of transfer, in accordance with the air carrier policy. Air carriers should ensure that this information is marked on the mobility aid tag so that the operators deliver the mobility aid to the location chosen by the passenger.

#### BEST PRACTICE

- ❖ The mobility aid should be returned to the passenger as close as possible to the door of the aircraft, unless specifically requested otherwise by the passenger.
- ❖ The mobility aid should be returned to the passenger at point of transfer wherever possible, unless specifically requested otherwise by the passenger.

## 7.3. Transferring Mobility Aids from Check-in /Gate to the Ramp

Once the mobility aid has been placed in an air travel configuration mode and is in the care of ramp personnel, the following steps should be taken to transfer the mobility aid to the ramp:

1. **Neutral/ Freewheel mode** – Ensure the mobility aid is in neutral/ freewheel mode before moving it.
2. **Elevator** – Where feasible, push the mobility aid to the nearest elevator at the airport. Avoid carrying the mobility aid down any stairs, as it increases the chances of dropping and damaging the mobility aid.

#### BEST PRACTICE:

- ❖ Ensure the mobility aid is in neutral/ freewheel mode when moving it.
- ❖ Use an elevator rather than carrying the mobility aid down the stairs.

## 7.4. Loading and Securing of Mobility Aids

Mobility aids must always be secured according to aircraft weight and balance requirements and the IATA Dangerous Goods Regulations. Currently mobility aids can be secured in the cargo compartment via two methods by loading into a Unit Load Devices (ULD) or bulk loading.

Aircraft cargo compartments may not be configured to utilize Unit Load Devices (ULDs). As such, mobility aids are transported in the cargo compartment along with other commodities, such as passenger baggage. The procedure for transportation of mobility aids differs greatly between ULD and bulk load aircraft. In all cases, mobility aids should be the last item loaded in the aircraft and the first item unloaded so that they can be delivered in a timely fashion to the passenger.

**BEST PRACTICE** is “last on, first off.”

## 7.5. Containerized Mobility Aids

Wherever possible, mobility aids should be secured in Unit Load Devices<sup>18</sup> (ULD) and loaded inside the aircraft cargo compartment. Loading mobility aids in ULDs reduces the chances of damage, as fewer ramp personnel handle the mobility aid and the mobility aid is protected during the flight.

**BEST PRACTICE** is to place the mobility aid in a ULD.

There are two kinds of ULDs – Aircraft Container or Combination of Aircraft Pallet and Aircraft Pallet Net –the below pictures identify some examples:

Example of Aircraft Container:

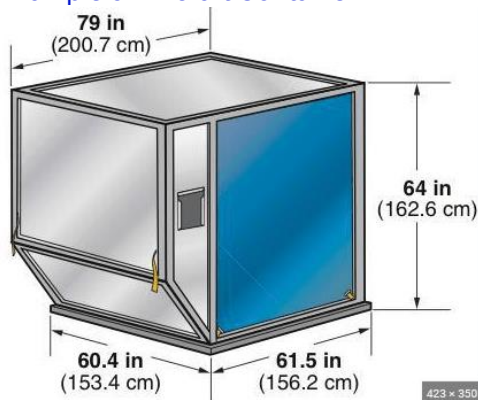

Example of Aircraft Pallet and Aircraft Pallet Net:



## 7.6. Securing the Mobility Aid in an Aircraft Container

Once the mobility aid is in air travel configuration mode, it can be loaded into an aircraft container. Air carriers should ensure the appropriate number of people are available to assist with lifting the mobility aid into the container, if necessary. The following is a list of steps that ramp personnel should undertake:

1. Place the mobility aid upright into the aircraft container.
2. Engage the drive system of the mobility aid.
3. Ensure mobility aid brakes are engaged if available.

<sup>18</sup> A Unit Load Device (ULD) is either an aircraft pallet and pallet net combination, or an aircraft container. ULDs are removable aircraft parts subject to strict civil aviation authorities' requirements from design, testing, production, and operations, to repair and maintenance. For more information see IATA [website](#)

4. If there is more than one mobility aid inside the container, ensure the mobility aids can be secured without touching each other or the sides of the container. This will help prevent damage to the mobility aids or the container.
5. Secure all mobility aids inside the container using straps and internal tie-down points of the container or follow airline guidance for proper securing techniques<sup>19</sup>.
6. Load the aircraft container in the aircraft closest to the aircraft cargo door for quick unloading at destination airport.
7. Close doors / flaps and otherwise secure the container for aircraft loading per airline policy.

**CAUTION:**

- ❖ Over securing (tightening straps too tight) can result in mobility aid damage.
- ❖ If any difficulty is encountered while loading or securing the mobility aid in the container, contact a supervisor for next steps.
- ❖ If the mobility aid cannot be loaded in the container, follow air carrier policy and notify the passenger to determine alternatives.

**Example 1 - Power chair strapped by the base, alone in the container:**

Credit: National Research Council Canada

**BEST PRACTICE:**

- ❖ Never load any other commodities inside the container with a mobility aid.
- ❖ Load the container containing the mobility aid into the aircraft last. This will facilitate fast unloading at the destination and expedite the return of the mobility aid to the passenger.
- ❖ List the mobility aid in the Load Distribution Message (LDM) or Container Pallet Message (CPM) in accordance with carrier policy, which ensures that the arrival station is aware and prepared to handle the mobility aid.

---

<sup>19</sup> See Appendix 2 for RESNA tips on how to identify anchor points on manual and power mobility aids.



## 7.7. Securing the Mobility Aid on an Aircraft Pallet

Once the mobility aid is fully in a travel configuration, it can be loaded onto an aircraft pallet and restrained by a compatible aircraft pallet net. Ensure the appropriate number of people are available to assist with lifting the mobility aid onto the pallet. The following is a list of steps that operators such as handlers should undertake:

1. Place the mobility aid upright onto the pallet.
2. Engage the drive system of the mobility aid.
3. Ensure mobility aid brakes are engaged if available.
4. If there is more than one mobility aid on the pallet, ensure the mobility aids can be secured without touching each other. This will help prevent damage to the mobility aids or the pallet.
5. Secure all mobility aid(s) on the aircraft pallet using the compatible aircraft pallet net and/ or restraint straps in accordance with carrier policy.

### NOTE:

- ❖ When aircraft pallet net is served as primary restraint, restraint straps may be used as supplemental restraint per carrier policy in order to stabilize the mobility aid and/or prevent it from shifting; however, when restraint straps are served as primary restraint, such 'strapping to pallet' is not defined as aircraft ULD but the so called 'Special Load'. The 'Special Load/ cargo operations engineering' function of the carrier must provide specific operating instructions to ensure safety compliance with the weight and balance manual of the intended aircraft.

6. Ensure the mobility aid(s) on the pallet is(are) not touching the adjacent pallet or the aircraft panel. This will help prevent damage to the mobility aids or the aircraft.
7. Load the pallet onto the aircraft closest to the aircraft cargo door for quick unload at destination airport.

### CAUTION:

- ❖ Over securing (tightening straps too tight) can result in mobility aid damage.
- ❖ If any difficulty is encountered while loading or securing the mobility aid in the ULD pallet, contact a supervisor for next steps.
- ❖ If the mobility aid cannot be loaded, follow airline policy and notify the passenger to determine alternatives.

### BEST PRACTICE:

- ❖ Never load any other commodities on a pallet with a mobility aid.
- ❖ Load the aircraft pallet containing the mobility aid into the aircraft last. This will facilitate fast unloading at the destination and expedite the return of the mobility aid to the passenger.
- ❖ List the mobility aid in the Load Distribution Message (LDM) or Container Pallet Message (CPM) in accordance with carrier policy, which ensures that the arrival station is aware and prepared to handle the mobility aid.

## 7.8. Bulk-Loaded Mobility Aid

For aircraft types that do not allow loading of cargo containers or other operational reasons such as last-minute notification and acceptance at the gate, mobility aids may be bulk loaded. Where it is not possible to load the mobility aid in a container, the mobility aid should be loaded and secured in the aircraft bulk cargo compartment as follows:

1. If carrier policy is to use aircraft baggage door shields, ensure that they are in place prior to moving the mobility aid into the aircraft.



2. The mobility aid should be put in travel configuration mode and on the ramp next to the belt loader positioned on the aircraft.
3. Engage drive system on the mobility aid.
4. Engage any brakes on the mobility aid.
5. Load the mobility aid in an upright position to avoid damage. Mobility aids are not currently designed for loading/transporting in bulk cargo compartments on their sides.

**CAUTION:**

- ❖ Avoid loading mobility aid on belt loaders with excessive angles to the aircraft cargo door, which may cause the mobility aid to fall, damaging the mobility aid and present risk of injuring ramp personnel.

Wherever possible, specialized ground service equipment should be deployed to lift the mobility aid from the ramp level up to the belt loader.

**Examples of Specialized Equipment**



**Credit: Open Doors**





Credit: Open Doors

**CAUTION:**

- ❖ Hand-lifting of large, heavy mobility aids by ramp personnel teams is discouraged and far more likely to cause damage to the mobility aid or injury to the ramp personnel.

6. Raise the mobility aid to the same height as the belt loader and place it onto the rubberized belt portion of the belt loader. This may require disengagement of the motors and brakes.
7. If specialized equipment is unavailable, ensure that an adequate number of qualified ramp personnel agents are present to perform a manual lift of the mobility aid, in accordance with carrier policy.
8. Place the mobility aid on the rubberized portion of the belt loader.
9. Ensure the mobility aid is properly centred on the belt, and that the path of travel on the belt for the mobility aid is clear.
10. Validate that the brakes are set, and the drive system is engaged prior to turning on the belt.

**CAUTION:**

- ❖ Prevent mobility aid from bumping into or getting caught on any portion of the belt loader or aircraft before engaging the belt, as this may cause the mobility aid to pivot/fall off from the belt loader during movement.

11. Engage the belt to move the mobility aid to the aircraft door, monitor for any potential shift of the mobility aid.
12. If the mobility aid gets caught or otherwise loses its centered position on the belt, **STOP** the belt; then
13. Reposition the mobility aid, remove obstacles and re-center the mobility aid on the rubberized portion of the belt.
14. Slow or stop the belt as needed to prevent unintended movement of the mobility aid.
15. If it becomes clear that the mobility aid will NOT fit into the aircraft cargo compartment, **STOP** the belt; then
  - Follow air carrier policy to inform the passenger of the situation
  - Offload the mobility aid from the belt loader; and
  - Continue loading other commodities as necessary.

**NOTE:**

- ❖ Creating a policy for a STOP or "safety time out" is an effective practice to encourage and authorize ramp personnel staff to: STOP, ASSESS, CONSULT and immediately ADDRESS the challenge that is presenting risk of damage to the mobility aid.

16. Avoid tipping or tilting the mobility aid, in accordance with carrier policy, to prevent damage to the mobility aid and injury to ground staff.
  - If a mobility aid has to be tipped to get through the cargo door, care should be given that the drive system is not disengaged.
  - If the mobility aid, in accordance with carrier policy, must be tilted or tipped on its side, it should not be tilted on the non-controller or joystick side.
17. Position the mobility aid inside the cargo compartment of the aircraft so that it can be secured:
  - The mobility aid should not come into contact with the aircraft cargo door frame while being loaded or unloaded as this may cause damage to the mobility aid and/or aircraft.
  - When moving the mobility aid inside the cargo compartment, freewheel mode must be engaged and the brakes released, otherwise the drive mechanism will be damaged. Once in place:
    - Ensure the mobility aid has its motors engaged and is not in freewheel mode.
    - Ensure any brakes are set prior to moving the mobility aid into the cargo hold.
    - Put the mobility aid into freewheel mode if needed to position the mobility aid inside the aircraft.
    - Ensure the mobility aid wheels are oriented in the direction of aircraft travel (example: forward or rear facing).
18. Prior to securing, evaluate the mobility aid for any damage. If any damage is identified, notify a supervisor and inform the passenger immediately per carrier policy.
19. Never place baggage or other commodities on top of a mobility aid.
20. Secure the mobility aid using procedures from the securing section of this manual.

**BEST PRACTICE:**

- ❖ Move the mobility aid through the cargo door in an upright position.
- ❖ Ensure the mobility aid is placed upright inside the cargo compartment.
- ❖ If the mobility aid cannot be placed upright inside the cargo compartment, contact a supervisor and handle in accordance with airline policy.
- ❖ If the mobility aid will not fit upright in the cargo compartment, follow carrier policy to inform the passenger
- ❖ Continue loading other commodities as necessary

## 7.9. Securing the Mobility Aid with Straps

Once the mobility aid is positioned correctly inside the aircraft, it can be secured. Mobility Aids may be secured on the cargo compartment floor, in containers and pallets with straps in accordance with air carrier policy. In case cargo straps are not available, the ramp personnel should follow the air carrier policy on how to secure the mobility aid inside the cargo compartment of the aircraft. No other commodity should be loaded on top of the mobility aid as a mean to secure it, and the mobility aid, including the controls, its battery(ies), and electrical cabling, if applicable, must be protected from damage by the movement of other commodities in the compartment.

Air carriers should list the presence of the mobility aid in the Load Distribution Message (LDM) or Container Pallet Message (CPM) in accordance with the air carrier policy, which ensures that the arrival station is aware and prepared to handle the mobility aid.

**Example of an aircraft strap:**



**Credit: Air Canada**

**CAUTION:**

- ❖ Do not attach cargo straps to or through leg supports, arm supports, spokes on wheels or other fragile locations.
- ❖ Once the straps are attached to the mobility aid, secure them to the aircraft cargo hold attachment points per individual airline policy.
- ❖ Do not over tighten straps – doing so may damage the mobility aid. Straps only need to be tight enough to prevent movement of the mobility aid inside the cargo compartment.
- ❖ Do not load any other commodities on top of the mobility aid.

According to existing practice, when only one strap is available, the strap should be attached to the aircraft cargo hold and then wrapped through and or around a designated securement location on the mobility aid.  
For further information, you can consult the Canadian Transportation Agency's Report on Mobility Aid Handling (see Appendix for reference).



**Credit: National Research Council of Canada**

**BEST PRACTICE:**

- ❖ List the mobility aid in the Load Distribution Message (LDM) or Container Pallet Message (CPM) in accordance with carrier policy, which ensures that the arrival station is aware and prepared to handle the mobility aid.
- ❖ Secure the mobility aid to the cargo compartment floor with straps
- ❖ Transport the mobility aid in a pit or bin with no other commodities inside

## Chapter 8. Reuniting Passengers with their Mobility Aid

Airports and airlines should have the equipment and resources necessary to unload the mobility aid safely and securely from the cargo compartment of the aircraft.

Assistance teams should not move the passenger into an aisle chair until the mobility aid is brought up to the aircraft door. Mobility aids should be brought to the passenger in a timely manner prior to any other baggage delivery.

In the event that the passenger requests delivery of the mobility aid at the baggage claim, or if the passenger requires assistance with moving through the terminal, airport personnel or other assistance services should assist from the aircraft all the way to the terminal curbside, connection point, or designated departure point (e.g. car parking lot, shuttle bus, bus station, railway station or taxi rank).

Assistance should also include assistance with the collection and transportation of passenger's baggage.

Upon arrival, the following steps should be taken to reunite the passenger with their mobility aid in working order as safely and efficiently as possible:

1. Cabin crew should help the passenger find and retrieve any items removed from the mobility aid and stored in the cabin.
2. The mobility aid should be returned to the location chosen by the passenger.
3. Ramp personnel should then take the following steps to prepare the mobility aid for the passenger:
  - a) **Reassembly** - Reattach components of the mobility aid for use, including joystick, electrical connections, seating, positioning etc.
  - b) **Battery** – Re-connect the battery power using the battery isolation switch if it has one or reconnect the batteries in accordance with IATA DGR and carrier policy.
  - c) **Reconfiguration** – Reconfigure the height of the mobility aid for use.
  - d) **Inspection:** Inspect the mobility aid for any damage that might have occurred. If damage occurs immediately notify the passenger in accordance with air carrier policy.
  - e) **Assistance:** Assistance teams within air carriers or airport should assist the passenger from the aisle chair into their mobility aid according to obligations under regulation.
  - f) **Drive System** – Engage the drive motors for the customer so the mobility aid is no longer in neutral. Remove any brakes that are engaged.

### 7.10. If the mobility aid is complex to handle, notify the next station of any helpful recommendations or information.

4. Airline operators should assist the passenger with any special service requests they might have made.





## Chapter 9: Irregular Operation (IROP)

### 9.1 General Principles

Irregular Operations (IROPs) are identified by an airline or ground handler acting on behalf of an airline when a disruption on the day of travel or the day prior to travel causes the customer to not be able to use the flight(s) ticketed.

An irregular operation (IROP) may be, but is not limited to, a flight delay, cancellation, diversion due to weather, mechanical problem, landing restriction, air traffic congestion, accident/aircraft damage, security concern, immigration issue, oversold flight, boarding delay, crew shortage or other staff issues<sup>20</sup>.

The airline resolving the IROP has the responsibility to ensure that passengers with disabilities make their new itinerary, including the transfer to their new flight and handling of their mobility aid and baggage. If time permits between flights, the airline should offer to return mobility aids to their owners and allow passengers to retain them until they need to be stored again for carriage.

In any IROP situation, effective communication with passengers is essential and key to providing good customer service. Special attention should be given to passengers in order to ensure the information has been appropriately transmitted and understood. Airlines should make all possible efforts to provide individual briefings to passengers relaying all pertinent information (flight delays, rerouting, etc.), using passengers' preferred communication method (e.g. face to face to allow for lip reading, in writing, etc.). Airlines should ensure that information pertaining to the passenger's needs and mobility aid information, including appropriate SSRs, are carried over onto the new booking.

## Chapter 10: Definition and Procedure in Case of Mishandling of Mobility Aids

The mishandling of a mobility aid occurs when the passenger arrives at destination or at a connection point and the mobility aid has either not arrived or is damaged when it is returned to the passenger. In the unfortunate case that a mobility aid is delayed or damaged upon loading or unloading, airlines should immediately communicate with passenger and inform them that the mobility aid is delayed or damaged.

The airline should initiate corrective measures in accordance with carrier policy and help the passenger determine any additional resources or arrangements.

In such cases, airlines should:

1. Make all reasonable efforts to ensure the amount of time the passenger is in an aisle chair is minimized.
2. Find a place where the passenger is comfortable. This may include an airport wheelchair or terminal passenger seating. If these alternatives are not safe for a passenger that requires custom seating for pressure management, this may include providing a location where the passenger can lie down.
3. In the case of a delayed mobility aid, begin the tracing process to locate the mobility aid.
4. Ensure that a chair is loaned to the passenger while they wait for their aid to arrive, be repaired or be replaced.

---

<sup>20</sup> [IATA, Interline Considerations on Irregular Operations \(IROPs\)](#)



5. Manage passengers' expectations regarding the fact that the loaner chair may not be as adapted to their needs as their own chair.
6. In the case of damaged mobility aid, begin procedures for a timely repair or replace the mobility aid through a repair company.
7. Assist passenger with claim filing, if assistance is required. Airlines should have available processes to allow the passenger to submit a claim, offering accessible assistive technology, and providing accessible information on their websites regarding how and when to file a claim, as required.

Airlines and airports should coordinate to ensure that they have access to a third-party service provider who can provide mobility aids to be loaned in the case of delay or damage. Airlines and airport operators should coordinate the timely repair or replacement of a mobility aid, as needed.

**NOTE:** Temporary repairs and modifications may be required to the passenger's mobility aid for allowing them to continue using their personal mobility aid.

## Chapter 11: Training

Training is an essential element in ensuring a safe regulatory regime. It is mandatory for all persons involved in the handling and carriage of dangerous goods, including battery-powered wheelchairs and mobility aids, to be trained to competently perform the function for which they are responsible.

Appropriate training for all staff in air travel service delivery is vital for providing quality service to persons with disability consistently and respectfully. It is essential that all airline staff know their responsibilities and can perform them competently. Training should address the attitudinal, environmental/physical and organisational barriers that affect persons with disabilities in air transport.

Training is required to prepare staff to aid persons with disabilities in a manner that respects their dignity, and as a professional service to which the person is entitled, rather than as a favour or compassionate gesture.

At a minimum, training material should include:

1. Disability awareness, including type of disabilities, how to communicate with the passenger, preserving dignity, privacy and independence, accepting choices, and eliminating barriers, understanding all aspects of the customer journey and the barriers that may be faced by them.
2. Understanding all relevant SSR codes for safe transportation of mobility aids and passenger assistance.
3. Overview of the relevant regulatory requirements.
4. For personnel responsible of the booking:
  - knowing what information to capture, how to capture it and communicate it to other relevant personnel
5. For ramp and airport personnel:
  - Understanding who is responsible for handling the mobility aid at which stage of transportation (e.g. according to regulatory requirements).
  - Transfer techniques for passengers with disabilities into and out of mobility aids/seats.
  - Understanding and respecting pre-boarding processes with sufficient time and privacy for passengers with disabilities to board with dignity.
  - Handling mobility aid batteries in accordance with IATA DGR, and airline standards and procedures.
  - Understanding mobility aid and safe lifting techniques.
  - Safe, common methods of reducing the size and weight of mobility aids for air travel.
  - Basic movement of mobility aids, freewheel mode for powered chairs, keys for scooters, brakes for manual wheelchair, in the terminal, on the ramp, on the belt loader and in the cargo compartment.





- Securement techniques for securing mobility aids in ULDs and in the bulk cargo compartment; and
- Steps to reassembly, reconfigure and prepare the mobility aid for delivery.

Training is required to include the policies and procedures of the organisation and should be appropriate to the duties of the person being trained and include emergency response procedures.

In addition to general training, airlines and airport operators should ensure that they train and maintain a continuous competence of their employees and contractors who are required to handle mobility aids. This will include procedures for preparing, securing, carrying and stowing of mobility aids for air transport.



# Appendix 1 – Aircraft Cargo Door Dimensions

The below air cargo door dimensions have been provided by the aircraft manufacturers (e.g. Boeing and Airbus). These are base manufacturer dimensions which do not include additional room for loading or manoeuvring a mobility aid into or out of the aircraft.

**NOTE:**

- ❖ Mobility aids which are of exactly the same dimensions as those listed in the table may NOT fit into the aircraft.
- ❖ Sufficient clearance is required around the mobility aid for ramp personnel to get it in the cargo compartment without damage to the mobility aid or to the aircraft. For example, certain aircraft cargo doors open inwards, reducing the clearance significantly.

## Boeing - Cargo door dimensions - single aisle aircraft

FWD cargo door width (small to large)									AFT cargo door width (small to large)								
Model	Maximum Passenger count	Maximum Range	FWD Cargo Door Width	FWD Cargo Door Height	Aft Cargo Door Width	Aft Cargo Door Height	bulk cargo door width	bulk cargo door height	Model	Maximum Passenger count	Maximum Range	FWD Cargo Door Width	FWD Cargo Door Height	Aft Cargo Door Width	Aft Cargo Door Height	bulk cargo door width	bulk cargo door height
CRJ1000	104	1425 NM	20.1	41.7	41.7	33.9			E195-E2	144	2000 NM	39.4	35.4	38.6	34.3		
CRJ900	90	1553 NM	20.1	41.7	41.7	33.9			E-195	122	1600 NM	39.4	35.4	38.6	34.3		
CRJ700	78	1378 NM	20.1	41.7	41.7	33.9			E-190	114	1850 NM	39.4	35.4	38.6	34.3		
CRJ705	75	1719 NM	20.1	41.7	41.7	33.9			E190-E2	114	2800 NM	39.4	35.4	38.6	34.3		
CRJ200	50	1644 NM	20.1	41.7	41.7	33.9			E175-E2	90	2060 NM	39.4	35.4	38.6	34.3		
Q400	90	1114 NM	24.0	53.9	50.8	59.8			E-175	88	1750 NM	39.4	35.4	38.6	34.3		
E195-E2	144	2000 NM	39.4	35.4	38.6	34.3			E 170	80	1800 NM	39.4	35.4	38.6	34.3		
E-195	122	1600 NM	39.4	35.4	38.6	34.3			CRJ1000	104	1425 NM	20.1	41.7	41.7	33.9		
E-190	114	1850 NM	39.4	35.4	38.6	34.3			CRJ900	90	1553 NM	20.1	41.7	41.7	33.9		
E190-E2	114	2800 NM	39.4	35.4	38.6	34.3			CRJ700	78	1378 NM	20.1	41.7	41.7	33.9		
E175-E2	90	2060 NM	39.4	35.4	38.6	34.3			CRJ705	75	1719 NM	20.1	41.7	41.7	33.9		
E-175	88	1750 NM	39.4	35.4	38.6	34.3			CRJ200	50	1644 NM	20.1	41.7	41.7	33.9		
E 170	80	1800 NM	39.4	35.4	38.6	34.3			A220/CS300	160	3350 NM	43.3	31.9	43.3	31.9		
A220/CS300	160	3350 NM	43.3	31.9	43.3	31.9			CS100	125	2950 NM	43.3	31.9	43.3	31.9		
CS100	125	2950 NM	43.3	31.9	43.3	31.9			737-900ER	220	5360 NM	48.0	35.0	48.0	32.7		
737-900ER	220	5360 NM	48.0	35.0	48.0	32.7			737-9MAX	220	3550 NM	48.0	35.0	48.0	32.7		
737-9MAX	220	3550 NM	48.0	35.0	48.0	32.7			737-8 MAX	210	3550 NM	48.0	35.0	48.0	32.7		
737-8 MAX	210	3550 NM	48.0	35.0	48.0	32.7			737-800	189	3115 NM	48.0	35.0	48.0	32.7		
737-800	189	3115 NM	48.0	35.0	48.0	32.7			737-900	189	3200 NM	48.0	35.0	48.0	32.7		
737-900	189	3200 NM	48.0	35.0	48.0	32.7			737-7 MAX	172	3850 NM	48.0	35.0	48.0	32.7		
737-7 MAX	172	3850 NM	48.0	35.0	48.0	32.7			737-600	149	3225 NM	48.0	35.0	48.0	32.7		
737-600	149	3225 NM	48.0	35.0	48.0	32.7			737-700	149	3400 NM	48.0	35.0	48.0	32.7		
737-700	149	3400 NM	48.0	35.0	48.0	32.7			737-700C	149	3285 NM	48.0	35.0	48.0	32.7		
737-700C	149	3285 NM	48.0	35.0	48.0	32.7			Q400	90	1114 NM	24.0	53.9	50.8	59.8		
A318	136	3100 NM	52.4	48.8	52.4	48.4			A318	136	3100 NM	52.4	48.8	52.4	48.4		
757-300	295	3390 NM	54.7	42.5	54.7	43.3			757-300	295	3390 NM	54.7	42.5	54.7	43.3		
757-200	239	3850 NM	54.7	42.5	54.7	43.3			757-200	239	3850 NM	54.7	42.5	54.7	43.3		
A321	236	3200 NM	71.3	48.8	71.3	40.2	37.4	30.3	A321	236	3200 NM	71.3	48.8	71.3	48.4	37.4	30.3
A320	180	3300 NM	71.3	48.8	71.3	40.2	37.4	30.3	A320	180	3300 NM	71.3	48.8	71.3	48.4	37.4	30.3
A319	156	3700 NM	71.3	48.8	71.3	40.2	37.4	30.3	A319	156	3700 NM	71.3	48.2	71.3	48.4	37.4	30.3

\* revision date December 2022

## Airbus cargo door dimensions<sup>21</sup>

The below dimensions are kindly provided by Airbus and represent the clearances of the cargo doors being relevant for the load's size to go inside the cargo compartment.

A320 cargo doors clearance width x height:

<sup>21</sup> revision date December 2022



FWD 1.82m x 1.24m (5.97ft x 4.07ft)  
AFT 1.82m x 1.23m (5.97ft x 4.04ft)  
BULK 0.95m x 0.77m (3.12ft x 2.53ft)

A330 cargo doors clearance width x height:

FWD 2.70m x 1.70m (8.86ft x 5.58ft)  
AFT 2.72m x 1.68m (8.92ft x 5.51ft)  
BULK 0.95m x 1.07m (3.12ft x 3.51ft)

A350 cargo doors clearance width x height:

FWD 2.91m x 1.76m (9.55ft x 5.77ft)  
AFT 2.85m x 1.75m (9.35ft x 5.74ft)  
BULK 0.95m x 0.76m (3.12ft x 2.49ft)

A380 cargo doors clearance width x height:

FWD 3.11m x 1.75m (10.20ft x 5.74ft)  
AFT 2.79m x 1.75m (9.15ft x 5.74ft)  
BULK 1.13m x 0.99m (3.71ft x 3.25ft)

The following two pictures (A320) explain the values.

**Picture number 1**

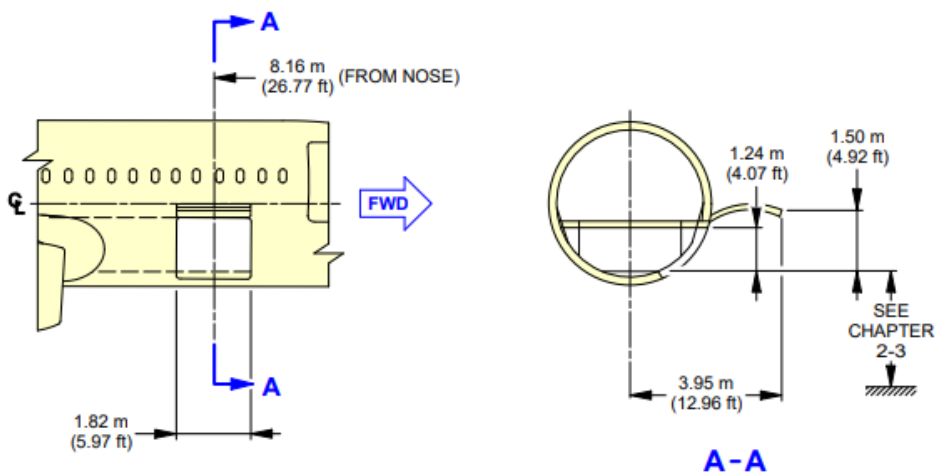

**Picture number 2**

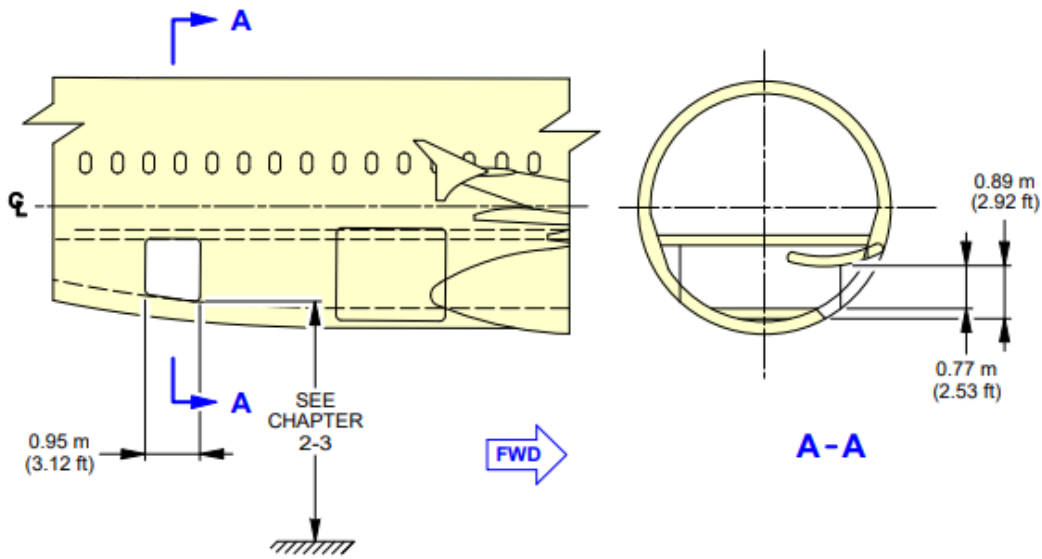

Credit: Airbus

# Appendix 2 – RESNA Air Travel Configuration Card

Examples of an air travel card for a mobility aid which meet the RESNA standard for air travel and which carriers might encounter.

Power Mobility Aid:

		<b>Manufacturer Model</b> COMPLIANT with RESNA AT-1
<b>owner:</b> John Doe <b>phone:</b> 123 456 7890 <b>email:</b> john.doe@email.com <b>chair serial number:</b> 7200003		
<h3>air travel preparation</h3> <p>The owner of this device, or a designated assistant, is encouraged to participate in the following process.</p> <ol style="list-style-type: none"> <li><b>remove seat cushion</b> Remove seat cushion; store in aircraft cabin.</li> <li><b>remove head support</b> Remove head support; store in aircraft cabin.</li> <li><b>lower back support to fit into aircraft</b> Remove back support cushion; store in aircraft cabin. Cushion is fixed in place by means of velcro on the rear. Disconnect quick release pin on back support actuator at the attachment point behind back support. Fold back support forward.</li> <li><b>remove joystick</b> Remove electrical connection to joystick. Remove joystick controller; store in aircraft cabin.</li> <li><b>raise foot supports</b> Move foot supports to upright position.</li> <li><b>isolate battery power</b> Switch breaker to off to fully disconnect power.</li> <li><b>disengage drive system</b> Rotate lever on each motor to manually push the mobility device.</li> </ol>	<h3>air travel configuration</h3> <p>601 mm (23.7 in)</p> <p>864 mm (34 in)</p> <p>Width: 635 mm (25 in)</p>	<h3>driving configuration</h3> <p>1207 mm (47.5 in)</p> <p>1064 mm (41.9 in)</p> <p>Width: 635 mm (25 in)</p>
	<b>unoccupied product weight</b> <b>150 kg (330 lb)</b> <b>WARNING:</b> This product should be lifted using a mechanical lift to avoid injury.	<b>battery information</b> <b>WARNING:</b> Only non-spillable lead acid group 34 batteries may be installed on this product. This wheelchair was manufactured with <b>2 lead acid sealed gel cell non-spillable batteries</b> conforming to DOT 49 CFR 173.159 (d) and IATA Provision A67.
	<b>weight of additional components</b> (if greater than 10 kg) <u>  12  </u> kg ( <u>  26.5  </u> lb)	rev: 2022-11-30

\*Note: this is an example of an air travel card for a mobility aid which meets the RESNA standard for air travel.  
**Credit: RESNA**

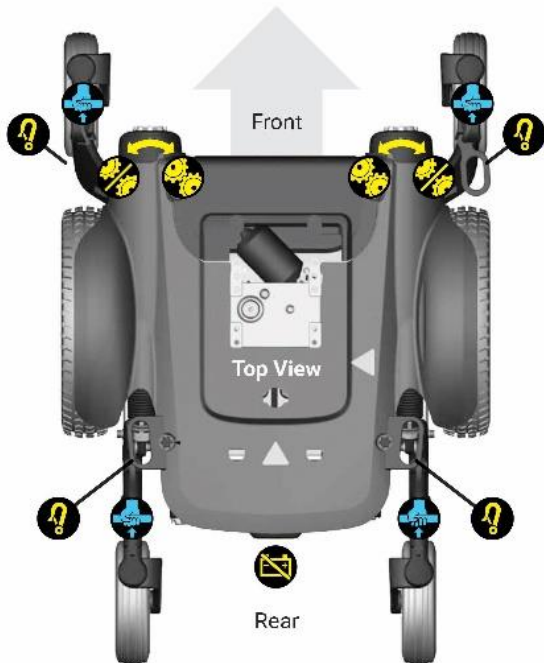
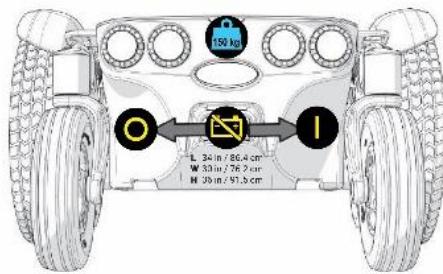

### isolate battery power SWITCH

Switch breaker to off to disconnect power from the battery. The circuit breaker is located in the rear beneath the tail lights.



### disengage drive system

Move levers outwards to release the brakes. Disengage drive motors with brake release levers to move product manually. The brake release levers are located at the front of the mobility device.



### manual lift points

Manual lift points are located on all four caster arms.

**WARNING!** This product should be lifted using a mechanical lift to avoid injury. Unoccupied product weight is 150 kg (330 lb).



### chair securement

RESNA WC19 securement points can be used to secure the mobility device. After positioning and securing the mobility device, re-engage the drive system to lock the drive wheels.



### user operator manual online

Scan the QR code to visit the RESNA ATAT webpage. Configuration card prototype was created based on the product having a built-in electrical isolation switch to isolate the batteries. Some data was obtained from user operator manuals available online. All values are estimated and may not represent actual product data. The manufacturers of the products on this card have not reviewed or approved this information.

14 CFR §382.129(a) states the following:

"As a carrier, you must permit passengers with a disability to provide written directions concerning the disassembly and reassembly of their wheelchairs, other mobility aids, and other assistive devices. **You must carry out these instructions to the greatest extent feasible...**"



owner: John Doe

phone: 123 456 7890

email: john.doe@email.com

chair serial number: 7200003

The owner of this device, or a designated assistant, is encouraged to participate in the following process.

- 1 **remove seat cushion** (user)  
Remove seat cushion; store in aircraft cabin.
- 2 **remove head support** (user)  
Remove head support; store in aircraft cabin.
- 3 **remove joystick** (user)  
Remove joystick controller; store in aircraft cabin.
- 4 **raise foot supports**  
Move foot supports to upright position.
- 5 **isolate battery power**  
Lift seat frame backwards to access battery box. Disconnect the 2 pin Anderson connectors from each battery to fully disconnect power. **See back page.**
- 6 **disengage drive system**  
If the joystick controller is not removed, first shut off power using the control panel. To manually push the device, rotate lever on each motor to release brakes.

## air travel configuration

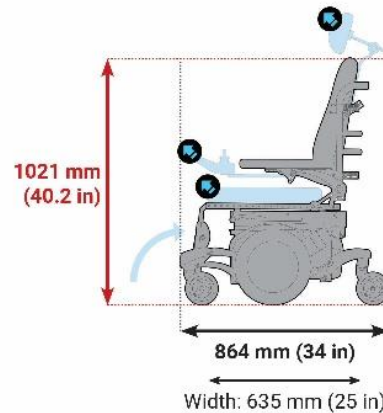

## driving configuration

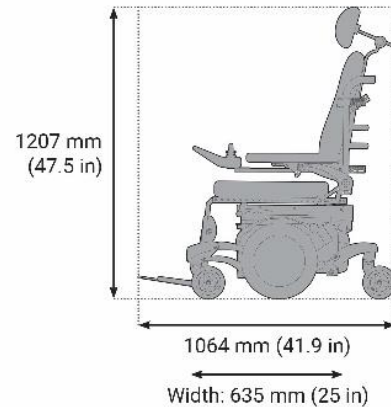

**unoccupied product weight**  
**150 kg (330 lb)**

**WARNING:** This product should be lifted using a mechanical lift to avoid injury.



**weight of additional components**  
(if greater than 10 kg)  
12 kg ( 26.5 lb)



### battery information

**WARNING:** Only sealed lead acid group 34 batteries may be installed on this product.

This wheelchair was manufactured with **2 lead acid sealed gel cell non-spillable batteries** conforming to DOT CFR 173.159 (d) and IATA Provision A67.

rev: 2022-11-30

\*Note: this is an example of an air travel card for a mobility aid that does not meet the RESNA AT-1 standard which air carriers may see.

Credit: RESNA





owner: John Doe      phone: 123 456 7890      email: john.doe@email.com      chair serial number: 7801034

The owner of this device, or a designated assistant, is encouraged to participate in the following process.

- 1 **remove key**  
Store key in bag attached to tiller.
- 2 **remove front basket**  
Store in aircraft cabin.
- 3 **fold and remove seat**  
(if required for height clearance)
- 4 **lock tiller in straight position**  
Push tiller lock knob in and turn it clockwise 90 degrees. The front wheel must face forward in order to lock the tiller.
- 6 **fold tiller down**  
Fold tiller down to folded position resting on seat.
- 7 **secure tiller in place**
- 8 **isolate battery power**  
Switch breaker to off to fully disconnect power.
- 7 **disengage drive system**  
Push lever on each motor forward to release the brakes, enabling the chair to be manually pushed.

## air travel configuration

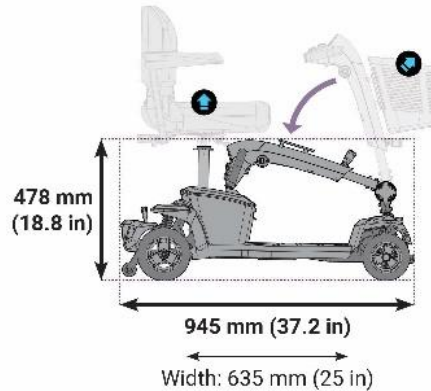

## driving configuration

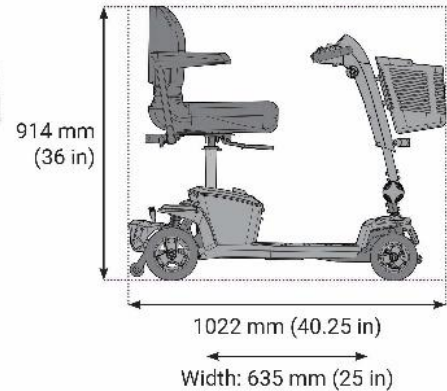

**unoccupied product weight**  
**52.7 kg (116 lb)**

**WARNING:** This product should be lifted using a mechanical lift to avoid injury.



### battery information

**WARNING:** Only sealed AGM or Gel-Cell type lead acid batteries may be installed on this product.

This wheelchair was manufactured with **2 lead acid sealed gel cell non-spillable batteries** conforming to DOT CFR 173.159 (d) and IATA Provision A67.



**weight of additional components**  
(if greater than 10 kg)

11 kg ( 24.3 lb)

rev: 2022-11-30

Credit: RESNA

### important air travel feature locations

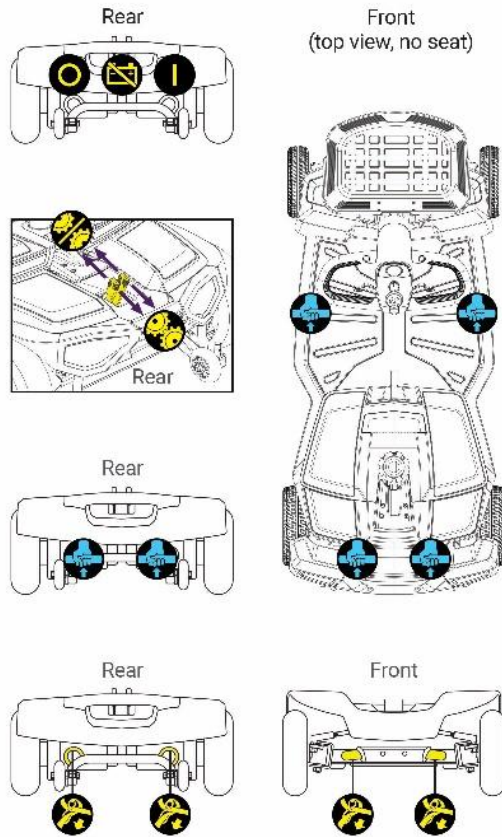

### isolate battery power

The circuit breaker is located on the top of the battery pack. It also acts as a battery isolator and is controlled via the lever located inside the hole at the top of the battery pack. **Switch breaker to off to disconnect power from the battery.**



### disengage drive system

Disengage drive wheels with brake release levers to move product manually. The brake release levers are located at the rear of the scooter. **Move levers forward to release the brakes.**



### manual lift points

**WARNING!** This product should be lifted using a mechanical lift to avoid injury. Unoccupied product weight is 52.7 kg (116 lb).

Side lifting points are located at the middle edges of the foot plate. Rear lifting points are located near the motors and the anti-tip wheels. Use securement points when lifting mechanically.



### chair securement

Re-engage the drive system to lock the device. Use cargo straps with or without the use of securement straps attached to the designated transit eye locations at the front and rear of the chair. The rear anchor points should be placed directly behind the rear securement points. The front anchor points should be placed wider than the scooter to provide increased lateral stability. **Attach fastening straps to marked securement points ONLY.**



### user operator manual online

Scan the QR code to visit the RESNA ATAT webpage. The make and model of wheelchair selected to draft this prototype of an air travel configuration card was modified for illustration purposes and does not represent a specific device. Some data was obtained from a sample user operator manual and specification sheet that was available online. Other values are estimated. The manufacturer of the product illustrated has not reviewed or approved this information.

**14 CFR §382.129(a):** "As a carrier, you must permit passengers with a disability to provide written directions concerning the disassembly and reassembly of their wheelchairs, other mobility aids, and other assistive devices. **You must carry out these instructions to the greatest extent feasible...**"

Credit: RESNA

owner: John Doe      phone: 123 456 7890      email: john.doe@email.com      chair serial number: 8760005

The owner of this device, or a designated assistant, is encouraged to participate in the following process.

- 1 remove seat cushion**  
Remove seat cushion; store in aircraft overhead bin.
- 2 fold and secure back support forward**  
Pull the release cord beneath the back support to rotate the back support forward until the back support locks in the folded position. Store in aircraft cabin overhead bin or closet.  
**WARNING!** When reconfiguring the chair in the driving configuration, ensure that the back support is fully locked in the proper position to prevent release of the back support and rearward tipping, which can result in injury or death.

- 3 remove rear wheels**  
Remove rear wheels; store in aircraft overhead bin.  
Remove the rear wheels by carefully performing the following steps:
  - Depress the quick-release button fully.
  - Remove wheel by sliding axle completely out of camber plug.
  - Repeat steps for opposite wheel.**NOTE:** When reattaching wheels, the axle is not locked until the quick-release button pops out fully. Always check to ensure that each axle is locked and secure by pulling on the wheel in the direction of the axle.

## air travel configuration

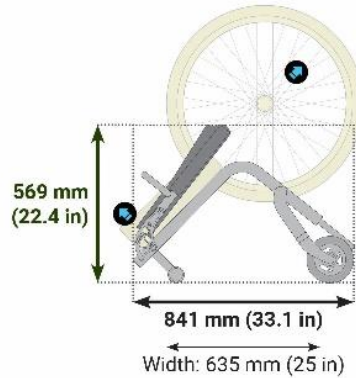

## driving configuration

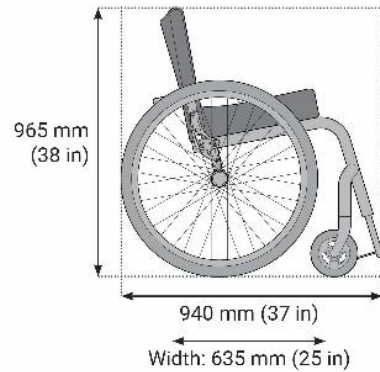

**unoccupied product weight**  
**6.4 kg (14 lb)**

**weight of additional components**  
 (if greater than 10 kg)  
11 kg ( 24.3 lb)

### important information

Ensure all detachable components (**highlighted yellow**) are properly secured before use.

**WARNING!** This chair is not to be used unless all detachable components have been checked for securement. Failure to check detachable parts could lead to failure of the device during use, causing a fall and resulting in injury or death.

rev: 2022-11-30

Credit: RESNA



### important air travel feature locations

model side views

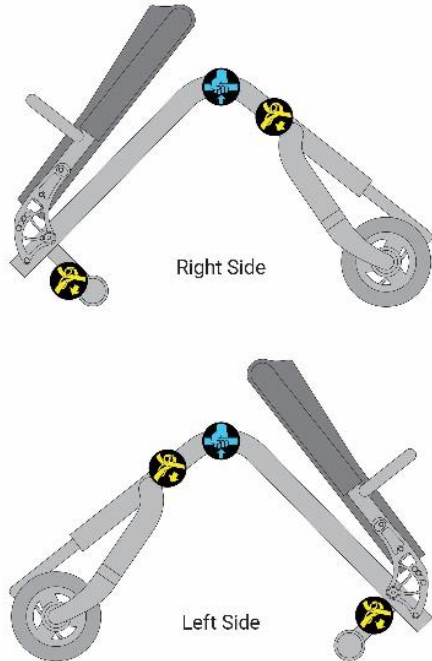

Both sides of the wheelchair in the Air Travel Configuration have been shown to illustrate the manual lifting points and the securement points along the non-detachable parts of the frame.



### manual lift points

**WARNING!** Do not lift the wheelchair while occupied. Lifting the wheelchair while the user is seated in the chair could lead to back injury or imbalance and tipping, resulting in injury or death.

**WARNING!** Do not lift this wheelchair by grasping the Back Support Release Cord or footrest or any other detachable element of the device. Detachable elements may not bear the weight of the device and may detach, leading to unexpected swinging or dropping, which could result in damage or injury to others.

Proper lifting technique should be maintained by keeping knees slightly bent and back upright.

Designated manual lifting points are located on non-detachable areas of the main frame. Failure to lift the device using the designated manual lift points may lead to dropping and accidental damage to the device or injury to others.

**Manual lift points are located in front of seat above front caster arms and on the main frame adjacent to seat cushion, near back support pivot point.**



### chair securement

**WARNING!** This chair is not designed to be occupied during transit. Move rider to an approved vehicle seat. Occupying the seat while in transit could cause the rider to be thrown from the chair in the event of a sudden stop, resulting in injury or death.

Attach the cargo straps (with or without the use of securement straps) to the designated securement points marked on the chair.



### user operator manual online

Scan the QR code to visit the RESNA ATAT webpage. The make and model of wheelchair selected to draft this prototype of an air travel configuration card is provided as an example only and does not represent a specific device. The QR code shall ideally link to the user operator manual and more online information. Scan the current QR code to learn more about RESNA Assistive Technology for Air Travel (ATAT) Standards.

**14 CFR §382.129(a):** "As a carrier, you must permit passengers with a disability to provide written directions concerning the disassembly and reassembly of their wheelchairs, other mobility aids, and other assistive devices. *You must carry out these instructions to the greatest extent feasible...*"

Credit: RESNA



## Appendix 3 - Job Aids- General Principles

Job Aids are valuable tools to facilitate consistent handling of mobility aids as they provide just the right amount of guidance, at the moment needed, for example a checklist. The purpose of a job aid is to provide the ramp personnel with a tool containing clear steps to follow when preparing a mobility aid for securement and containment in the cargo compartment of the aircraft, should they have questions about securement.

Listed below are core reasons for job aids, (courtesy of The Canadian Transportation Agency) and various sample job aids.

- ❖ **The reasons to have a job aid are:** skill fade, low recurrence of training, training that is not applied (e.g., hands-on) and/or not compliant with training regulations. Graphics and lay language become the primary mode of communicating the validated tasks.
  
- ❖ **Job aids should:**
  - Be easy to use and as standardized as possible;
  - Contain clearly defined high-level steps for securement and containment.
  - Written in simple language
  - Rely on visuals for quick reference.

### Job Aid number 1- Getting familiar with the Mobility Aid

**Game Planning: The customer service agent initiates meeting with the ramp personnel and the passenger**

1. Verify airline tags/carrier procedures are complete (including battery type)
2. Verify if photos are available to determine if the battery has to be removed<sup>22</sup>.
3. With passenger help, get familiar with the mobility aid:
  - a) Identify how to lower the height and what the lowered height will be
  - b) Assess if mobility aid (in air travel configuration) will fit in the cargo hold
    - if no –communicate with the passenger and escalate as per carrier policy
  - c) Identify the power isolation switch or where to disconnect the power near the batteries
  - d) Identify how to activate the freewheel mode into neutral
  - e) Identify the lift points
  - f) Identify the securement points
  - g) Identify which parts are removable (with passenger permission)
  - h) Learn how to place the mobility aid in air travel configuration mode
  - i) Confirm the mobility aid is properly tagged

---

<sup>22</sup> If the battery can be well protected and can be securely attached to the mobility aid, it may not be necessary to remove it.

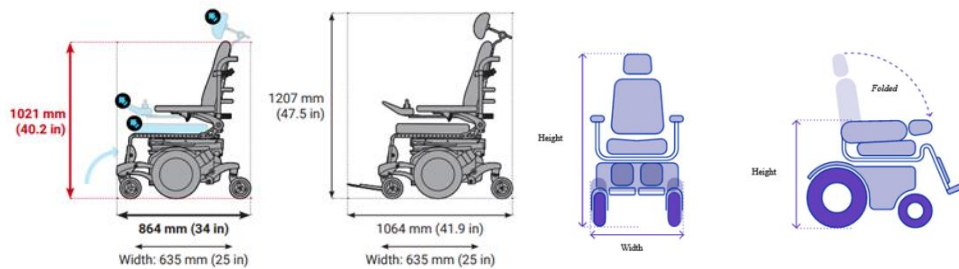

Credit: RESNA

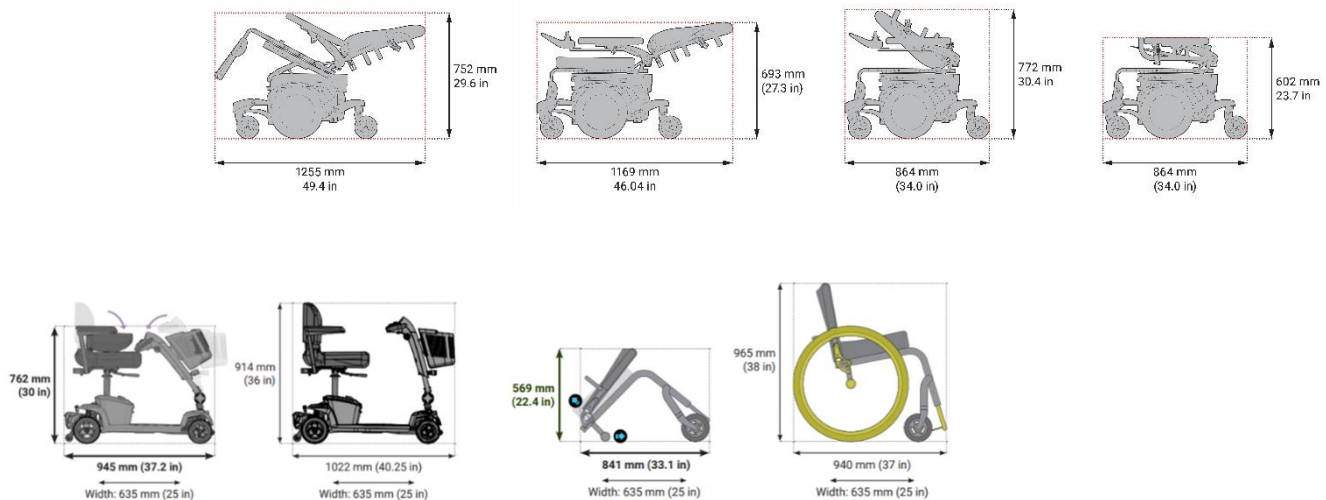

Credit: RESNA

## Job Aid number 2- Placing the Mobility Aid into Air Travel Configuration

**Game Planning:** The customer service agent initiates the meeting with the ramp agent and the passenger.

1. Verify airline tags/carrier procedures are complete (including battery type)
2. Transfer passenger out of mobility aid
3. With the passenger or personal care attendant's guidance, place the mobility aid into an air travel configuration mode.
4. Reduce the height of the mobility aid as much as possible to best enable the mobility aid to safely fit through the cargo door
5. Verify the lowered height of the Mobility Aid
6. Confirm the Mobility Aid (in the air travel configuration mode) will fit through the cargo door and in the cargo compartment
  - a. if not – escalate as per carrier policy
7. Remove/give removable parts to passenger (w/ passenger permission for stowage onboard to prevent loss or damage)
8. Use the power isolation switch to isolate the batteries or disconnect the quick-disconnect power cable to the batteries
9. Verify the location of the lift points
10. Verify the location of the best securement points

11. Confirm the mobility aid is properly tagged
12. Disengage the motors to put the mobility aid into neutral and disengage the brakes
13. Transport the Mobility Aid to the ramp/ aircraft

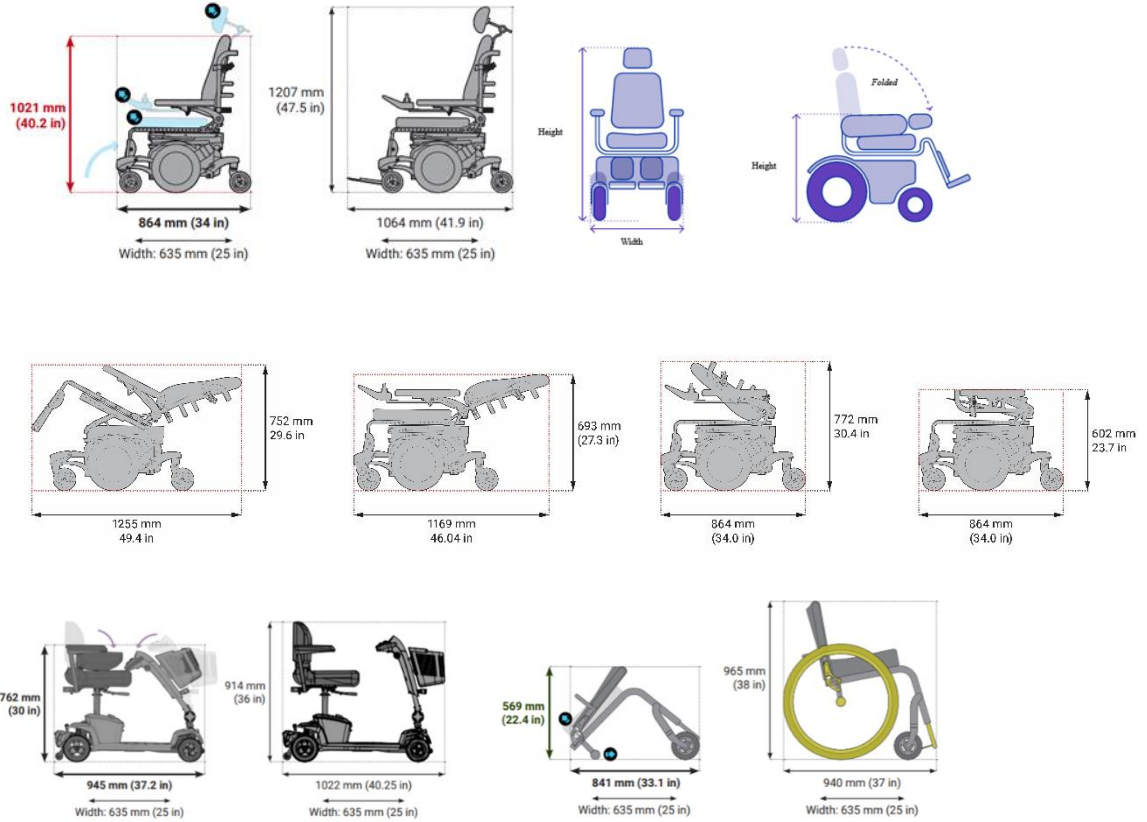

Credit: RESNA



## Job Aid number 3- Bulk Loading and Unloading at the Ramp

**Game Planning: At departure/ the ramp personnel receives mobility aid at the ramp adjacent to the aircraft**

1. Load mobility aid on last, so it is first off upon arrival
2. Pre-position specialized mobility aid loading and securement equipment
3. Verify adequate number of trained staff are available to assist in loading
4. Confirm the mobility aid is properly tagged/meets (carrier) requirements for loading
5. Verify the mobility aid is in air travel configuration mode

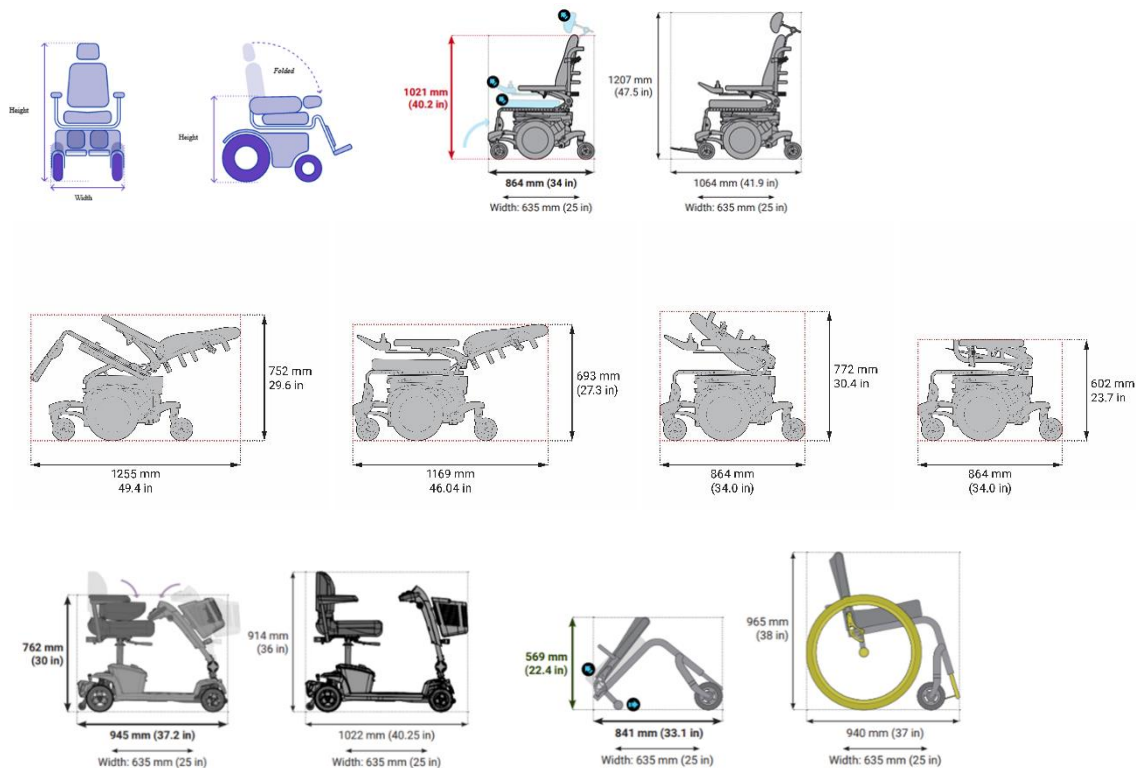

**Credit: RESNA**

6. Assess if the mobility aid (in air travel configuration mode) will safely:
  - a) fit on belt loader
  - b) fit through cargo door (with/without tipping) in accordance with carrier policy
  - c) fit in cargo compartment for stowage/securement in accordance with carrier policy
7. Decision:
  - if yes proceed
  - if no – escalate as per carrier policy
8. Load the mobility aid on the belt loader
9. Engage drive mechanism (to ensure mobility aid does not roll during belt movement)
10. Move mobility aid through the cargo door, ideally in an upright position to minimize damage (in accordance with carrier policy)
  - a) Include specific carrier policy for moving the mobility aid through the cargo door here: \_\_\_\_\_
11. Secure the mobility aid in cargo compartment in an upright position to minimize damage (in accordance with carrier policy)
  - a) Include specific carrier policy for moving the mobility aid through the cargo door here: \_\_\_\_\_



12. Utilize straps to secure the mobility aid in cargo hold (show picture)
13. Baggage may be placed around mobility aid (but not on the mobility aid) (in accordance with carrier policy)

**Game Planning: on arrival**

1. Inspect and report any damage to the mobility aid prior to moving out of the aircraft
  - a) If damage is found, escalate per carrier policy
2. Move the mobility aid through cargo door and onto belt loader (per carrier policy) and ensure drive system is engaged and brakes are set
3. Ensure the mobility aid is centered on the belt loader and move it down the belt loader
4. Transfer the mobility air onto ramp (using specialized equipment/preferred) or adequate # of staff.
5. Disengage the drive system and release the brake once on ground level
6. Return the mobility aid to the passenger

## Job Aid number 4 - Containerized Loading at the Ramp

**Game Planning:** at departure/ ramp personnel receives mobility aid at the ramp adjacent to the aircraft

1. Confirm the mobility aid is properly tagged/meets (carrier) requirements for loading
2. Engage freewheel mode and disengage brakes – or mobility aid will be damaged
3. Verify mobility aid is in air travel configuration mode if necessary for transport

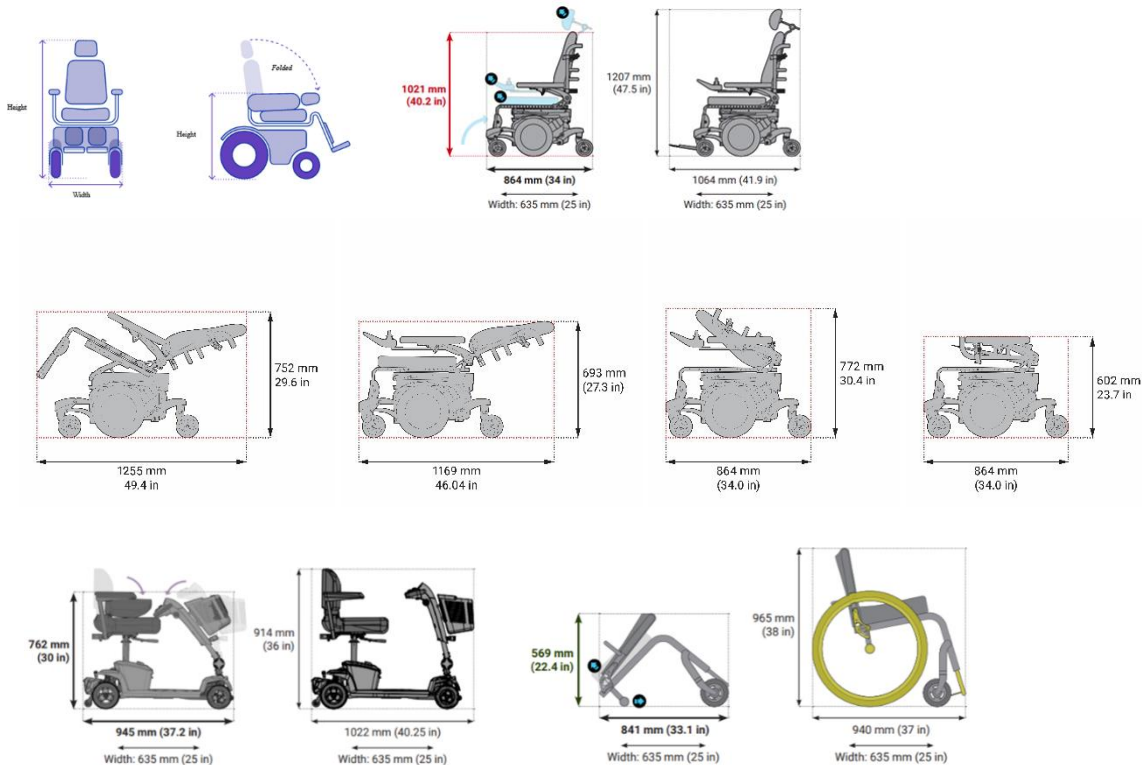

**Credit: RESNA**

4. Assess if the mobility aid (in air travel configuration mode) will safely:
  - a. fit in container
5. Decision:
  - if yes proceed
  - if no – escalate as per carrier policy
6. Load mobility aid in the container
7. Disengage freewheel mode and engage brakes
8. Secure the mobility aid in the container (per carrier policy)
  - a. Include specific carrier policy for securement here: \_\_\_\_\_
9. Load container in the aircraft (per carrier policy)

❖ **BEST PRACTICE:** load the container onto the aircraft closest to the aircraft cargo door for quick unloading at destination airport.

**Game planning: On arrival**



1. Breakdown the container
2. Engage freewheel mode and disengage brakes
3. Remove the mobility aid from the container
4. Inspect and report any damage to the mobility aid
  - a. If damage is found, escalate per carrier policy
5. Return the mobility aid to the passenger



## Appendix 4- Areas for Future Consideration

During the collaborative process of creating this manual, a number of opportunities were identified for further and ongoing exploratory action, that involve issues the MAAG was at time of drafting unable to resolve, into what could appropriately be described as a current “best practice” by structural barriers that require solutions beyond the scope of this guidance ambit.

### The Intersection of Air Travel and Assistive Technology is a Dynamic Environment

1. As an industry, IATA and its members recognize the impact to passengers traveling with mobility aids when damage to or a loss of their mobility aids occurs. We are committed to iteratively narrowing the “fit gap” between transport-category commercial aircraft and the range of often highly customized mobility assistive aids that exist today and is widely recognized as a primary causal factor contributing to the loss and damage these best practices are intended to prevent. In the interim, however, execution of the best practices detailed within this manual – and implementation of future updates – will have a tangible impact on the reduction of damage to mobility aids.
2. Progress continually being made in mobility aids and aircraft design is likely to facilitate better solutions to structural barriers than are currently feasible due to existing design limitations among both aircraft and mobility aids, neither of which have historically been designed with the other in mind.
3. While airlines continue working to drive accessibility enhancements with the suppliers of our fleet equipment, progress in the development and customer-procurement of mobility aids designed to support air travel must continue apace, with the support of all stakeholders including wheelchair manufacturers and purchase-funding entities, aircraft and aviation-equipment manufacturers, airlines and the accessibility advocacy community. A great example of such collaboration is the RESNA standards work referenced elsewhere in this document, which the MAAG gratefully recognizes here.
4. The MAAG recommends that air carriers utilize the best practices described in this manual to develop robust and comprehensive, airline-specific processes for ensuring end-to-end management of the safe and efficient transport of passengers traveling with mobility aids. An enterprise-wide approach to accessibility enhancement will further inform carriers’ leadership team members and process auditors regarding these best practices and their ongoing development, so that they can be executed consistently and efficiently throughout the organization as a whole.

## Appendix 5 - Areas for further refinement

### Quality Assurance (QA) Audits

The guidelines within this manual are intended to provide airlines and other operators with a number of best practices. An important step is to ask questions and validate that your operational teams are executing these best practices. By creating and using a “Quality Assurance” (QA) process, you will identify additional opportunities to improve your team’s compliance with these best practices. It is strongly encouraged to create a structure where your leadership has direct oversight of the process in the operation and use auditing tools to capture relevant data on compliance.

## Using Specialized equipment, “Loading Plates” on Belt Loaders

A loading plate can be used to minimize potential damage during bulk loading of mobility aids via ground support equipment (i.e., belt loaders). These plates are designed to be simple to use and prevent the mobility aid from falling off the moving belt.



**Credit: Open Doors**





**Credit: Open Doors**

## Mobility aid transfer cart

This is a concept where air carriers/ airports can use a type of manually operated cart to transport the mobility aid while inside the airport terminal. The cart would need to be robust enough to handle a heavy electric mobility aid, while also small enough to manoeuvre within the gate environment and any elevators (lifts) while the mobility aid is properly stored within. The purpose of this type of manual cart is to move the mobility aid from the passenger's location (most likely in the gate hold area) through the terminal and down to the ramp level where it can safely be loaded into the aircraft.



**Credit: Open Doors**





Note: This is an example of a mobility aid transfer cart that can fit in an elevator  
Credit: Open Doors

## Delay Handling

Air carriers could be strategic when making decisions to accommodate mobility aids. Since the safe transportation of mobility aids is a high priority, carriers should consider making operational allowances to accommodate passengers and their mobility aids outside of the normal departure timeline, should the circumstances require additional time.

## Safety Time Out

Due to the critical nature of handling mobility aids, there may be instances where uncertainty or miscommunication can occur. It is critically important to train the staff who handle these types of mobility aids about these instances and STOP the operation if there is any confusion or issues. By stopping the operation and giving time to find a proper solution to the issue, operational pressures are minimised which may force inadequate or improper decisions from happening. Operational leaders need to allow the time and space for personnel working through these issues for the safest and best outcomes.

## Storage of Straps in Aircraft or Cargo Compartment

Straps may be stored in storage pouches inside the cargo compartment or the passenger cabin to keep straps inside each aircraft. This practice has been shown to address the problem of straps being unavailable from the ramp teams – since they would be traveling with the aircraft with or without a mobility aid in the cargo hold every time the aircraft departs.



## Photograph of Secured Mobility Aid (Bulk Loading)

Carriers should consider having ramp personnel photograph the secured mobility aid and send to personnel unloading mobility aid at destination. This would document the loading and allow visual communication to the arrival airport of how and where the mobility aid was secured in the aircraft. If possible, allow the photo of the secured mobility aid to be sent electronically to the passenger at the time of securement. This informs the passenger that the mobility aid is loaded on the same aircraft with them, and that the mobility aid is secured within the aircraft.

## Passenger Communication

A best practice concept is to notify the passenger that their mobility aid has been loaded on the aircraft. If any delay or damage has occurred to the mobility aid, the gate agent and passenger should promptly be notified, so the agent can initiate corrective measures in accordance with carrier policy and help the passenger determine any necessary resources or arrangements.

## Coordination Between Air Carriers and Airports

Coordination with airports is encouraged to ensure that accessible infrastructure is incorporated into airport environments. This includes expedient access to specialized equipment for the loading/unloading of mobility aids.

## Innovation to Prevent the Mobility Aid from Rolling Backwards on a Belt Loader

Airlines should find new tools or ways to secure a mobility aid while it is in neutral on an inclined belt loader in order to move it safely into or out of the cargo compartment. This could be ground equipment or aircraft chocks, or some type of securement plate. This could also be technology built into the mobility aid to prevent movement while inclined, similar to the hill hold assist feature that certain manual transmission cars now have.

## Identify Actual and Real-World dimensions for Aircraft Cargo Door Dimensions

There must be a distinction between actual aircraft cargo door dimensions and usable dimensions which allows ramp teams to use arms to manoeuvre mobility aids into the cargo compartment without damaging the aircraft, the mobility aid or injuring themselves.



## References

The information provided in this guidance builds and expands on the following IATA Resolutions and Recommended Practices which can be found in the [IATA Passenger Standards Conference Manual \(PSCM\)](#):

- Resolution 700: Acceptance and Carriage of Passengers Requiring Special Assistance;
- Resolution 745b: Acceptance of Power-Driven Wheelchairs or Other Battery Powered Mobility Aids as Checked Baggage;

The guidance contains references to the following manuals and guidance material:

- [IATA Dangerous Good Regulation \(DGR\)](#);
- [IATA Battery Powered Wheelchair and Mobility Aid Guidance Document](#)
- [IATA Cabin Operations Safety Best Practices Guide \(COSBPG\)](#);
- [A4A-IATA Reservations Interline Procedures \(AIRIMP\)](#);
- [RESNA Standard](#)
- [British Standard Wheelchair Passport Scheme](#)
- [Canadian Transportation Agency Mobility Aids and Air Travel Report](#)
- [National Research Council of Canada - Safe Securement and Containment of Mobility Aids in the Cargo Compartment \(Phase 2\)](#)
- [UK Safety Notice SN 2012/003 - Safety Requirements Applicable to the Carriage of Electric Mobility Aids](#)

## Acronyms

**ANSI** American national standards institute, member body to the international standards organization (ISO).

**DGR** - Dangerous Goods Regulation

**IATA** – International Air Transport Association

**IROP** - Irregular Operation

**ISO** - International Organization for Standardization.

**MAAG** - Mobility Aids Action Group

**PNR** - Passenger Name Record

**PRM** - Persons with Reduced Mobility

**PSCM** - IATA Passengers Standards Conference Manual

**PWD** – Persons with Disabilities

**RESNA** - Rehabilitation Engineering and Assistive Technology Society of North America.

**SSR** - Special Service Request