

CE6000-120AP

CUTTING PLOTTER

USER'S MANUAL

MANUAL NO.CE60AP-UM-153



GRAPHTEC

TO ENSURE SAFE AND CORRECT USE

- To ensure the safe and correct use of your plotter, read this manual thoroughly prior to use.
- After reading this manual, keep it in a handy location for quick reference as necessary.
- Do not allow small children to touch the plotter.
- The following describes important points for safe operation. Be sure to observe them strictly.

Conventions Used in This Manual

To ensure the safe and accurate use of the plotter as well as to prevent human injury and property damage, the safety precautions provided in this manual are ranked in the three categories described below. Their display and meaning is as following. Be sure to gain a full understanding of the meaning of them before reading the Manual.



This category provides information that, if ignored, is highly likely to cause fatal or serious injury to the operator.





This category provides information that, if ignored, is likely to cause fatal or serious injury to the operator.





This category provides information that, if ignored, could cause injury to the operator or damage to the plotter.

Description of Safety Symbols





The  symbol indicates information that requires careful attention (including warnings). The specific point requiring attention is described by an illustration or text within or next to the  symbol.



The  symbol indicates an action that is prohibited. Such prohibited action is described by an illustration or text within or next to the  symbol.



The  symbol indicates an action that must be performed. Such imperative action is described by an illustration or text within or next to the  symbol.

Safety Precautions

! WARNING

Do not touch the moving parts such as rollers and tool carriage while cutting or plotting is in progress.

- Such action may result in injury.



No touching

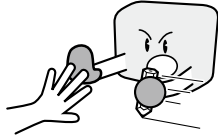

Be sure to ground the earth terminal.

- If the plotter is not grounded, the operator could suffer an electric shock in the event of current leakage.



Ground the Plotter

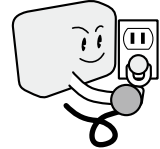

Keep your hands, hair, etc., away from the rollers or moving parts such as the carriage even if the plotter is stopped, as it may suddenly start moving when data is received.

- Such action may result in injury.



No touching

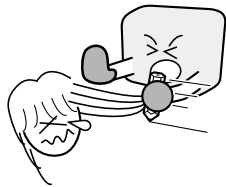

Do not disassemble, repair, or remodel the plotter.

- Such action may cause electric shock or a fire hazard due to current leakage.
- Contact with the high-voltage parts within the plotter may cause electric shock.
- If the plotter requires repairs, contact your sales representative or nearest Graphtec vendor.



No disassembly



Do not connect the plotter to a non-rated power supply.

- Such action may cause electric shock or a fire hazard due to current leakage.



Prohibited



Do not use the plotter in a location where it will be exposed to water, rain, or snow.

- Such action may cause electric shock or a fire hazard due to current leakage.



Avoid water



Beware of electrical shock

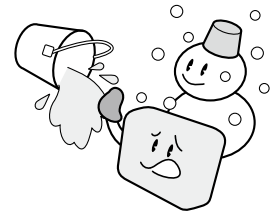

If the plotter generates smoke, overheats, emits a strange odor, or otherwise functions abnormally, do not continue using it. Turn off the power and unplug the power cord from the electrical socket.

- Use of the plotter in such a condition may result in a fire hazard or electric shock.
- After confirming that smoke is no longer being emitted, contact your sales representative or nearest Graphtec vendor for repairs.
- Never attempt to perform repairs yourself. Repair work by inexperienced personnel is extremely dangerous.



Prohibited

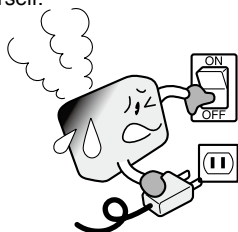

Do not allow dust or metal scraps to adhere to the power plug.

- Such action may cause electric shock or a fire hazard due to current leakage.



Prohibited



Beware of electrical shock

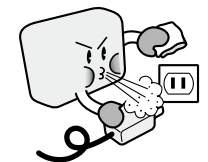

Safety Precautions

! WARNING

Do not use the power cord if it is damaged.

- Use of a damaged cord may result in electric shock or a fire hazard due to current leakage.
- Replace the power cord with a new one.



Unplug the power cord from the socket

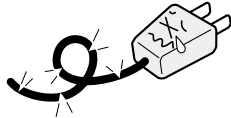

Be careful when handling the cutter blade.

- Touching the blade with your bare hand may cause injury.
- Do not touch the cutter blade while cutting is in progress.



No touching

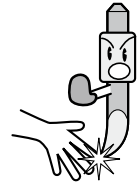

! CAUTION

Do not use or store the plotter in a location exposed to direct sunlight or the direct draft of an air conditioner or heater.

- Such locations may impair the performance of the plotter.



Prohibited

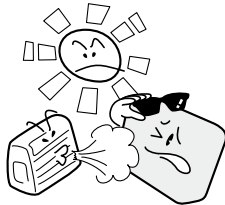

Do not use the plotter in an excessively dusty or humid location.

- Such locations may impair the performance of the plotter.



Prohibited



Do not place any receptacle containing water or other fluid on top of the plotter.

- Fluid falling inside the plotter may cause electric shock or a fire hazard due to current leakage.



Avoid water



Beware of electrical shock



Do not use the plotter in a location subject to excessive mechanical vibration or electrical noise.

- Such locations may impair the performance of the plotter.



Prohibited

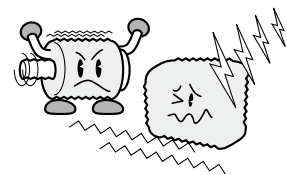

When disconnecting the power cord or interface cable, do not pull on the cord/cable.

- Such action will damage the cord/cable, resulting in a fire hazard or electric shock.



Prohibited

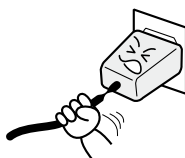

If water or foreign matter enters the plotter, discontinue use. Turn off the power and unplug the power cord from the electrical socket.

- Use of a damaged cord may result in electric shock or a fire hazard due to current leakage.
- Contact your sales representative or nearest Graphtec vendor for repairs.



Unplug the power cord from the socket

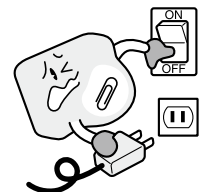

Safety Precautions



Do not attempt to lubricate the cutting-plotter mechanisms.

- Such action may cause it to break down.



Prohibited

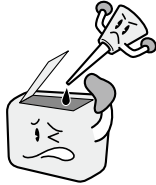

Do not clean the plotter using volatile solvents such as thinner or benzene.

- Such action may impair its performance.



Prohibited

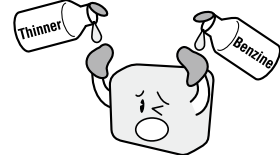

Provide sufficient space around the plotter so that it does not strike any objects in its vicinity during cutting.

- Such contact may cause misalignment in cutting or plotting.



No touching

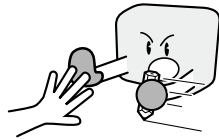

When using indoor lighting such as fluorescent or other electrical lamps, provide a distance of at least one meter between the plotter and the light source.

- Close proximity of such a light source may cause the sensor to malfunction and prevent proper size detection of the media.

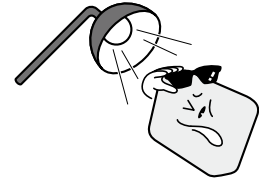

When using the cutter, take care not to extend the blade more than necessary.

- An overly extended blade will damage the cutting mat and adversely affect the cutting quality.

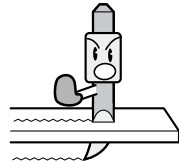

Move the tool carriage slowly when moving it manually in order to load the medium or for other reasons.

- Moving it quickly may damage the plotter.

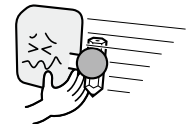

Do not place the plotter on an incline, areas subject to many vibrations, or other unstable locations.

- If the plotter falls, it may sustain damage.



Prohibited



Do not place magnetic cards, diskettes or similar items in the vicinity of the tool carriage.

- The magnetic force may destroy the data on the magnetic cards or diskettes.



Prohibited

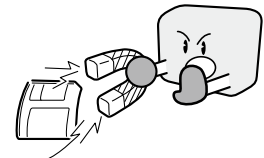

Run a test cut when cutting media with unknown condition settings.

- Running a cut operation with incorrect setting values may cause a large overload to the blades and device or a system breakdown.



Preface

Thank you for choosing a Graphtec CE6000-120AP plotter. The CE6000-120AP plotters employ a digital servo drive system to achieve high-speed and high-precision cutting. In addition to cutting with any perforation pattern, the CE6000-120AP plotter can also be used as a pen plotter. To ensure high cutting quality and optimal productivity, be sure to read this User's Manual thoroughly prior to use.

Notes on this Manual

- (1) No part of this publication may be reproduced, stored in a retrieval system, or transmitted, in any form or by any means, without the prior written permission of Graphtec Corporation.
- (2) The product specifications and other information in this manual are subject to change without notice.
- (3) While every effort has been made to provide complete and accurate information, please contact your sales representative or nearest Graphtec vendor if you find any unclear or erroneous information or wish to make other comments or suggestions.
- (4) Notwithstanding the stipulations in the preceding paragraph, Graphtec Corporation assumes no liability for damages resulting from either the use of the information contained herein or the use of the product.

Registered Trademarks

All names of companies, brands, logotypes, and products appearing in this manual are the trademarks or registered trademarks of their respective companies.

Copyright

This User's Manual is copyrighted by Graphtec Corporation.

Instruction Manual

The Instruction Manual is included as a PDF on the CD-ROM, and gives detailed explanations on the operation of this machine.

Special Precautions on Handling Blades

Sharp cutter blades are used with this plotter. Handle the cutter blades and holders with care to prevent bodily injury.

Cutter Blades

Cutter blades are very sharp. While handling a cutter blade or cutter pen, be careful to avoid cutting your fingers or other parts of your body. Promptly return used blades to the cutter case provided.

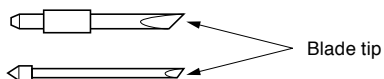

When the case is completely filled, discard the used blades together with the case.

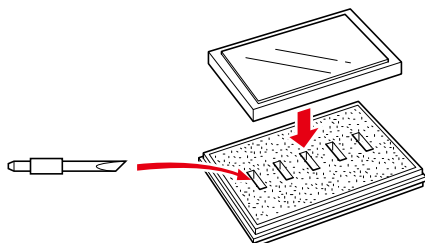

Cutter Pens

The tip consists of a sharp blade. Be sure not to extend it too far. Moreover, when you are not using the cutter pen, make sure that the blade is fully retracted.

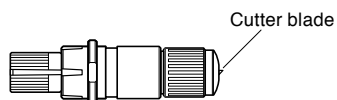

After Mounting the Cutter Pen

After the power has been turned on, and during operation, do not touch the pen tip. It is dangerous.

After Turning on the Plotter

During the course of turning on the plotter, be sure to observe the following precautions. The tool carriage and loaded media may suddenly move during the cutting operation, immediately afterward and when setting the plotter's functions. Keep hands, hair, clothing and other objects out of the vicinity of the tool carriage, grit rollers and loaded media. To prevent operator injury and poor cutting results, be careful not to allow hands, hair, clothing or other foreign objects to become entangled with the tool carriage or loaded media while the plotter is operating.



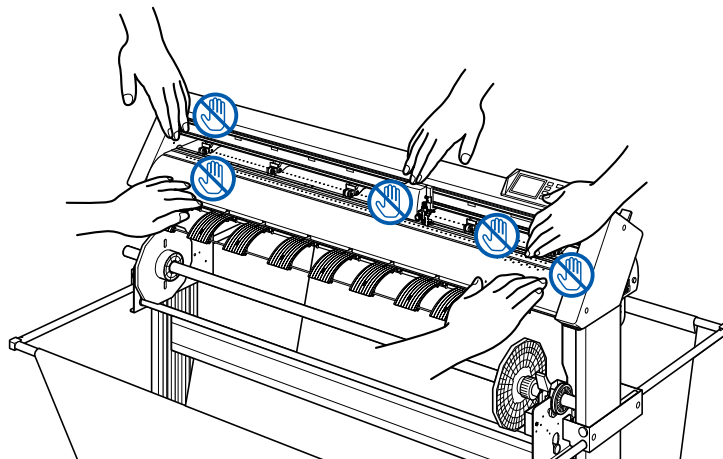

During a plotting or cutting operation, do not touch the gears, rollers, or other moving parts.

Please be careful not to get your fingers pinched or stuck on the gears, rollers, or other moving parts when loading the medium.



Machine Caution Label

The machine's Caution Label is located on the top cover. Be sure to observe all the cautions on the label.

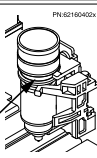
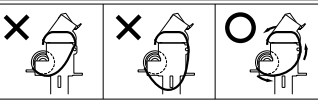
			△ 注意 カット／作図中はローラーや、キャリッジ等の可動部に絶対さわらないでください。	△ CAUTION During a cutting or plotting operation, do not touch the writingpanel or moving parts such as the carriage.	△ ATTENTION Lors d'une opération de découpe ou de traçage, ne touchez pas le panneau écritoire ou les pièces en mouvement comme le chariot.	△ ACHTUNG △ ATENCION △ ATTENZIONE	
△ CAUTION During a cutting or plotting operation, do not touch the writingpanel or moving parts such as the gear. When you are installing media, be careful for gears, rollers, etc. not to pinch your finger.		Setting the stock shaft stopper ストックシャフトストッパーのセット方法 FREE LOCK	△ CAUTION Make sure that the pen is correctly mounted as shown in the diagram. Note: The pen must be mounted in the pen station when the power is turned on.			△ 注意 ペンは図のよう正しく取り付けてください。 ※電源投入時ペンは必ずステーション裏に取り付けてください。 Fit the bracket into upper groove. ペンの上側の溝にはめる。	Please take out the media that finished the cutting. If next cutting is performed without removing the finished media, the media may skew during cutting. 作図が終了した用紙は、必ずバスケッドから取り出してください。バスケッドの中に作図済みの用紙が残った状態で次の作図を行うと紙ズリなど不具合の原因となります。

About the words and phrases in this text

- In this instruction manual, the word "plot" refers to operating the machine and using either the plotting pen or the cutter pen to cut.
- In this instruction manual, the word "media" refers to paper, roll, or sheet media.

Prior to use

- Be sure to read the attached TO ENSURE SAFE AND CORRECT USE prior to use. Otherwise, it may cause an unexpected accident or fire.

Notes on the basket

If the supplied basket is not used, problems in cutting quality may occur. Be sure to use the basket.

Notes on the paper (media)

Please use the paper (media) in accordance with the following precautions.

- The paper is sensitive to temperature and humidity, and can start to stretch or contract immediately upon removal from the roll. Cutting/plotting the media immediately after taking it off causes it to stretch and may blur or cause deviations in the images.
- Please make sure to store the paper at the same environment (temperature/humidity) as this machine.
- Please always line up the edge of the paper.
Misalignment may cause skewing and mis-cuts.
- About the end of the roll media and the paper roll.
The cutting or plotting may differ depending on how the roll media ended or how the paper roll was stopped.
- About the paper roll.
This machine uses rolls with an internal diameter of 3 inches, or 76.2 mm. Mis-cuts or plotting deviations may occur if the paper roll is warped or has a larger internal diameter.
- Please make sure to use the Paper Exposure Time and Number of Pre Feeds settings.
The media can start to stretch or contract after it is taken off the roll. Changes in temperature and/or humidity affect the paper's contractibility and saturation time, and may cause mis-cuts or plotting deviations.
To prevent this from occurring, this machine is preset for Paper Exposure Time at 180 seconds, and Number of Pre Feeds at 2. For details on how to change these settings, see "Setting Paper Exposure Time" and "Setting the Number of Pre Feeds" in Section 4.
- Using the thin media (70 g/m²)
When the cutting speed is too fast, the media deviations may occur. Reduce the cutting speed to use the thin media.
Especially, please reduce the cutting speed in low humidity environment.

Operating environment

With regard to changes in the operating environment, we guarantee the precision of our products under the following conditions:

- The paper used is Graphtec brand for this machine.
- The Paper Ready Time and Number of Pre Feeds are the manufactures settings of 180 seconds and 2 times.
- There are no changes in the storage temperature and humidity levels.
- If there are changes, the repeatable accuracy is equivalent to 0.1 mm per degree Celsius or 0.3 mm per 10% Relative humidity.
- The paper is re-set after 5 consecutive page cuts.
- Each page is removed from the basket after cutting.
- Connection of a ground wire is required.
 - * When the ground wire is not connected, the machine may be affected by static electricity.
When using the machine without connecting a ground wire, there may be adversely affected in the cutting results. Make sure that the machine is grounded.

WARNING

The United States Federal Communications Commission has specified that the following notice must be brought to the attention of users of this product.

FEDERAL COMMUNICATIONS COMMISSION RADIO FREQUENCY INTERFERENCE STATEMENT

NOTE: This equipment has been tested and found to comply with the limits for a Class A digital device, pursuant to part 15 of the FCC Rules. These limits are designed to provide reasonable protection against harmful interference when the equipment is operated in a commercial environment.

This equipment generates, uses, and can radiate radio frequency energy and, if not installed and used in accordance with the instruction manual, may cause harmful interference to radio communications. Operation of this equipment in a residential area is likely to cause harmful interference in which case the user will be required to correct the interference at his own expense.

USE SHIELDED CABLES

To comply with FCC Class A requirements, all external data interface cables and connectors must be properly shielded and grounded. Proper cables and connectors are available from GRAPHTEC's authorized dealers or manufacturers of computers or peripherals. GRAPHTEC is not responsible for any interference caused by using cables and connectors other than those recommended or by unauthorized changes or modifications to this equipment. Unauthorized changes or modifications could void the user's authority to operate the equipment.

To use a media wider than 1,119 mm

When using the left grit roller, set the push roller to the position of 2 mm from the right edge (A in the figure below).

Depending on the media size, adjust the position of the push roller of the long right grit roller.

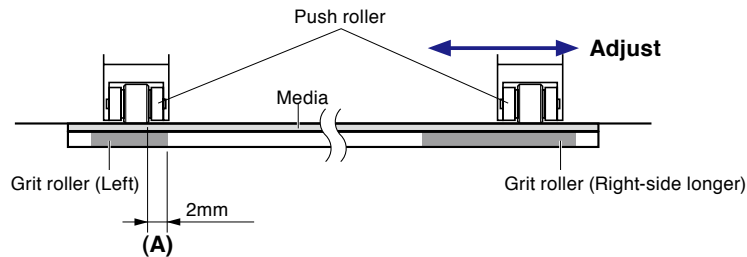

Notes on the left grit roller

The left grit roller is not available in all locations.

It's not possible to set the right edge of the grit roller to a size greater than 8 mm. (There is a stopper.)

Please set the push roller to the position between 2 mm and 8 mm from the right edge of the grit roller.

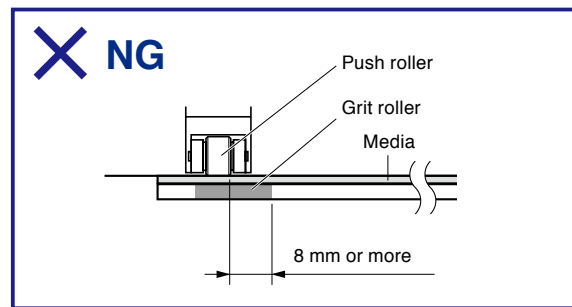
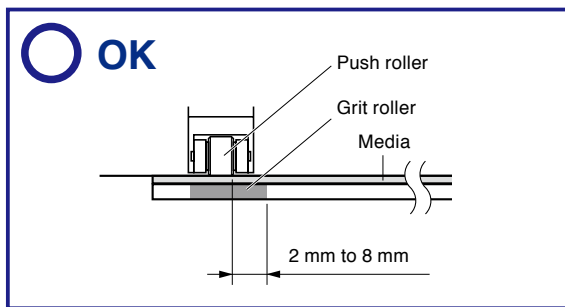

Notes on the crosscut

When setting the push roller to the left grit roller, the length of the crosscut will be as follows.

Please note the position you want to set the media.

- When the position to set the push roller is 2 mm to 4 mm or less from the right edge of the grit roller, the crosscut from the left edge of the push roller will be 15 mm.

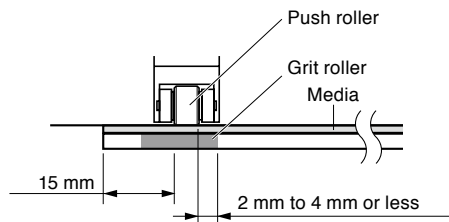

- When the position to set the push roller is 4 mm or more to 8 mm from the right-side of the grit roller, the crosscut from the left-side of the push roller is 10 mm.

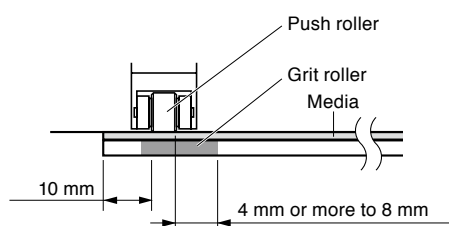

Selecting a Power Cable

Be sure to refer to the following tables if you wish to use a cable other than the one supplied as an accessory.

Table 1. 100 V to 120 V Power Supply Voltage Range

Plug Configuration	Plug Type	Supply Voltage Selector Settings	Reference Standards	Power Cable
	North America 125 V 10 A	100/120 V	ANSI C73.11 NEMA 5-15 UL498/817/62 CSA22.2 NO.42/21/49	UL Listed Type SJT No.18AWG x 3 300 V, 10 A

Table 2. 200 V to 240 V Power Supply Voltage Range

Plug Configuration	Plug Type	Supply Voltage Selector Settings	Reference Standards	Power Cable
	Europe 250 V 10 A	200 V	CEE(7)VII IEC320 CEE13	TYPE: H05VV-F 3 x 1.0 mm ²
	UK 250 V 5 A	200 V	BS1363 BS4491 BS6500	TYPE: H05VV-F 3 x 1.0 mm ²
	Australia 250 V 10 A	200 V	AS3112 AS3109 AS3191	TYPE: OD3CFC 3 x 1.0 mm ²
	North America 250 V 15 A	200 V	ANSI C73.20 NEMA 6-15 UL 198.6	UL Listed Type SJT No.18AWG x 3 300 V, 10 A
	Switzerland 250 V 6 A	200 V	SEV1011 SEV1004 SEV1012	TYPE: H05VV-F 3 x 0.75 mm ²
	China 250 V 6 A	200 V	GB15934 GB2099.1 GB1002 GB/T 5023.5	TYPE: H05VV-F 3 x 1.0 mm ²

CONTENTS

TO ENSURE SAFE AND CORRECT USE	i
Safety Precautions	ii
Preface	I
Notes on this Manual	I
Registered Trademarks	I
Copyright	I
Instruction Manual	I
Special Precautions on Handling Blades	II
Cutter Blades	II
Cutter Pens	II
After Mounting the Cutter Pen	II
After Turning on the Plotter	III
Machine Caution Label	III
About the words and phrases in this text	III
Prior to use	IV
Notes on the basket	IV
Notes on the paper (media)	IV
Operating environment	V
WARNING	V
FEDERAL COMMUNICATIONS COMMISSION RADIO FREQUENCY INTERFERENCE STATEMENT	V
USE SHIELDED CABLES	V
To use a media wider than 1,119 mm	VI
Selecting a Power Cable	VII

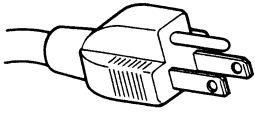
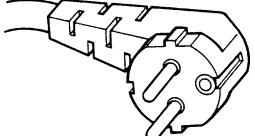
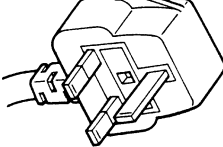
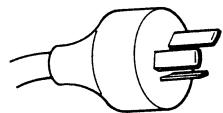
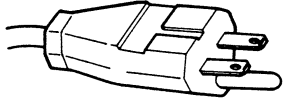
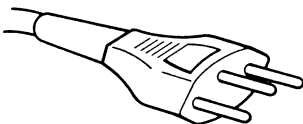
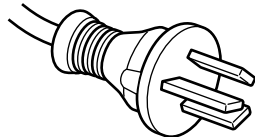
Chapter 1 Product Summary

1.1	Checking the Accessories	1-2
	Accessories	1-2
1.2	Nomenclature	1-3
	Front View	1-3
	Rear View	1-4
1.3	Assembling	1-5
	Components of stand	1-5
	Components of basket	1-5
	Attaching a media guide	1-11
1.4	Connecting to the Computer	1-12

Chapter 2: Preparing to Cut

2.1	Preparation of Cutter Plunger	2-2
	Cutter Plunger Nomenclature	2-2
	Structure of Cutter Plunger	2-2
	Adjusting the Blade Length	2-2
	Blade Application and Features	2-3
2.2	Attaching a Tool	2-4
	Attaching a cutter plunger	2-4
	Removing the cutter plunger	2-5
	Attaching a pen	2-6
	Removing a pen	2-6

2.3	Loading Media (Paper)	2-7
	Loading Roll Media	2-7
	Loading Sheet Media	2-14
2.4	Aligning the Push Rollers	2-16
	Aligning the Push Roller	2-16
	When Feeding Long-axis Media (at exceeds 2 meters)	2-16
	When Feeding Long-axis Media (at least 2 meters)	2-17
	To use a paper wider than 1,119 mm	2-17
	For minimum width media.	2-17
	Changing the Hold-down Force	2-18
	Switching	2-18
2.5	About the Default Screen	2-19
2.6	Connecting to the Power	2-20
2.7	How to Use Control Panel	2-21
	Control Keys	2-21
	Menu Keys.	2-21
	Indicator Lamp.	2-22
	Reading the Screen (LCD)	2-22
	Default Screen (Ready Screen)	2-22
	Contents of Operation from Menu Screen.	2-24
	Simple menu.	2-24
	Normal menu	2-24
	Contents of Operation from [COND/TEST] Key	2-25
2.8	Setting Feeding Method	2-26
2.9	Auto media transfer and cross cut	2-28
2.10	Selecting Tool Condition	2-29
	Selecting Tool Condition.	2-29
	Setting the Tool Condition	2-30
	Setting the Tool	2-31
	Setting Condition No.1 (Pen plunger specific)	2-31
	Setting for Condition No.2 to No.8 (For cutter plunger)	2-32
	Setting the Speed	2-34
	Setting the Force.	2-35
	Setting the Acceleration	2-36
	Adjust the Blade Length	2-37
2.11	Setting Cut Line Pattern	2-38
2.12	Running Cutting Tests	2-41
	Cutting Test.	2-41
	Confirm the Results of the Cutting Test.	2-42
	Adjustment of Offset	2-42
	Adjustment for Cutting Out.	2-42
	Adjustment When Using Plotting Pen.	2-42
2.13	About Simple menu	2-43
2.13.1	Setting Page Length (Simple mode)	2-44
2.13.2	Setting the number of pre feeds (Simple menu)	2-46
2.13.3	User selection settings (Simple menu)	2-47
2.13.4	Setting RS-232C interface (Simple menu)	2-49
	Changing and saving the RS-232C interface settings	2-49
2.13.5	Display Length Unit Settings (Length Unit) (Simple menu)	2-52

Chapter 3: Basic Operations

3.1	Raise or Lower the Tool	3-2
3.2	Move the Tool Carriage and Media	3-3
	Move in Steps Manually	3-3
	Continuously Move Manually	3-3
	Setting of Step Movement Distance	3-4
	Move Away the Tool Carriage	3-5
	Change the Cutting Condition (Condition No.)	3-6
	Reset (Revert to the initial state when the power was turned on.)	3-6
3.3	Setting the Origin Point	3-7
	When Coordinate Axes Rotation are Set	3-8
	When Coordinate Axes are Rotated After Origin Point is Set	3-8
	Setting Origin Point When HP-GL is Set	3-9
3.4	Setting the Cutting Direction	3-10
3.5	Stop Cutting	3-12
	Pause and Resume Cutting	3-12
	Stop Cutting	3-13

Chapter 4: Convenient Functions

4.1	Settings for Cutting	4-2
	Setting Cutting Area	4-2
	Setting Cutting Width (EXPAND)	4-4
	Setting Length of the Page	4-5
	Setting the number of pre feeds	4-7
	Setting paper Ready time	4-8
	Setting the space rear	4-9
4.2	Copy (Duplicate Cutting)	4-11
	When Media Change mode is off	4-11
	When Media Change mode is on	4-14
4.3	Panel Cutting	4-16
4.4	Setting a cross cut	4-18
4.5	Setting a cut (F_CUT) for F command	4-19
4.6	Setting a force for cross cut	4-20

Chapter 5: Manual Position Adjust

5.1	Outline of Manual Position Adjust	5-2
	Alignment registration mark	5-2
	Example of axis adjustment	5-2
5.2	Adjusting coordinate Axes	5-3
	Setting the start point	5-3

Chapter 6: Setting Regarding Cutting Quality

6.1	To cut the corner of thick media sharply	6-2
	Outline of TANGENTIAL MODE	6-2
	Setting the Tangential Mode	6-3
	Setting Length of the Overcut	6-4
	Setting of the Initial Down Force	6-6
6.2	Setting the Step Pass	6-7
6.3	Setting the Offset Angle	6-8

6.4	Setting the Distance Adjust	6-10
6.5	Setting Initial Blade Control Position Adjust	6-12
6.6	Settings for OFFSET FORCE	6-14
6.7	Blade Wear Detection	6-15
	Checking the Wear Rate	6-15
	BLADE WEAR DETECT	6-16
	SET BLADE GROUP (blade wear group settings)	6-17
	BLADE WEAR SETUP (Blade wear factor settings)	6-18
	CLEAR B. WEAR VALUE (estimated distance method)	6-20
6.8	Adjust the space between tools 1 and 2	6-22

Chapter 7: Settings Regarding Cutting Time

7.1	Sorting the Cutting Data.	7-2
7.2	Perform Automatic Pre Feed When Cut Data is Received.	7-4
7.3	Perform Automatic Pre Feed When Media is Set (Initial Feed)	7-6
7.4	Setting Feed Speed for Pre Feed	7-8
7.5	Setting the Tool Up Speed	7-10
7.6	Setting the Tool Up Move.	7-12

Chapter 8: Setting Regarding Interface

8.1	Setting Interface.	8-2
	USB Interface	8-2
	RS-232C Interface.	8-2
	Interface Setting Menu	8-2
	Connecting with RS-232C.	8-3
	Setting user selection	8-3
	Switching the user selection setting	8-4
	Changing and saving the RS-232C interface setting	8-5
8.2	Setting a separator.	8-8
	GP-GL Separator.	8-8
	HP-GL Separattorr	8-9
8.3	Setting a timeout	8-11

Chapter 9: Settings Regarding Operation Environment

	Related to Menu Display	9-2
	Display Language Setting (LANGUAGE SELECTION)	9-2
	Display Length Unit Settings (LENGTH UNIT)	9-3
	Related to Sensor	9-4
	Enabling/Disabling the Media Sensors (MEDIA SENSOR)	9-4
	Enabling/Disabling the Push Roller Sensors (PUSH ROLLER SENSOR)	9-5
	Related to Plotter Environment	9-6
	Fan Suction Setting (FAN POWER)	9-6
	Enabling/Disabling the Beep Setting (BEEP FOR KEY OPERATION).	9-7

Chapter 10: Settings of Controls from Computer

	Related to Command Processing	10-2
	Setting the Command (COMMAND).	10-2
	Priority of Tool Condition Selection (CONDITION PRIORITY)	10-3

Related to GP-GL Command	10-4
Setting the Step Size (GP-GL STEP SIZE)	10-4
Enabling/Disabling the ':' and ';' Commands (COMMAND ':',';').	10-5
Moving the Pen While Raised or Lowered in Response to the 'W' Command (COMMAND 'W')	10-6
Related to HP-GL Command	10-7
Model ID Response (HP-GL MODEL EMULATED)	10-7
Circle-Command Resolution Setting (CIRCLE RESOLUTION)	10-8

Chapter 11: Maintenance

11.1	Daily Maintenance	11-2
	Daily Maintenance	11-2
	Storing the Plotter	11-2
11.2	Replacing Cutter Blade	11-3
11.3	Cleaning the Cutter Pen	11-4
11.4	Cutter Plunger Exchange	11-5

Chapter 12: Troubleshooting

12.1	Troubleshooting	12-2
	When the Plotter Does Not Operate After Turning the Power On	12-2
	When It Does Not Work Right	12-3
	When the Cutting Result is Not Good	12-5
	Error Messages in GP-GL Command Mode	12-6
	Error Messages in HP-GL Command Mode	12-7
	AXIS Error Messages	12-9
	Other Error Messages	12-10
	Caution Message	12-12
12.2	Printing the Setting of the Plotter	12-13
12.3	Creating Test Pattern	12-15
12.4	Confirm the Cutting Data	12-17
12.5	Cutting a CUT DEMO	12-19
12.6	Self Diagnostic Test	12-21

Appendix

A.1	Main Specifications	A-2
A.2	Supplies	A-3
	Supplies	A-3
A.3	External Dimensions	A-4
	CE6000-120AP	A-4
A.4	Menu Tree	A-5
	Simple Menu	A-5
	Normal Menu	A-6
A.5	Initial Setting	A-11
	Simple Menu	A-11
	Normal Menu	A-11

INDEX	I-1
-----------------	-----

Chapter 1 Product Summary

This chapter explains how to connect this device your computer.







PRODUCT SUMMARY

- 1.1 Checking the Accessories***
- 1.2 Nomenclature***
- 1.3 Assembling***
- 1.4 Connecting to the Computer***

1.1

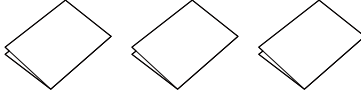
Checking the Accessories

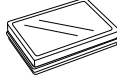
Accessories

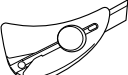
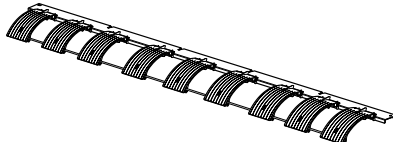
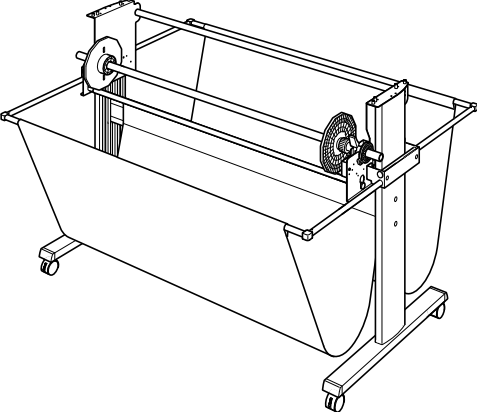
Item	Q'ty	Item	Q'ty
Power cable 	1 pc	USB cable 	1 pc
CD  • Various software • User's Manual (pdf)	2 pcs	SETUP MANUAL, TO ENSURE SAFE AND CORRECT USE Cutter Blade Manual 	1 of each
Cutter holder (PHP33-CB09N-HS) 	1 pc	Cutter blades 	1 pc
Oil-based ballpoint pen plunger (PHP34-BALL) 	1 set	Oil-based ballpoint pen (KB700-BK-1P) 	1 pc
Media Cutter 	1 pc	Media guide  * Packaged with the stand.	1 set
Stand 	1 set		

*Other software data may be added later.

1.2

Nomenclature

Front View

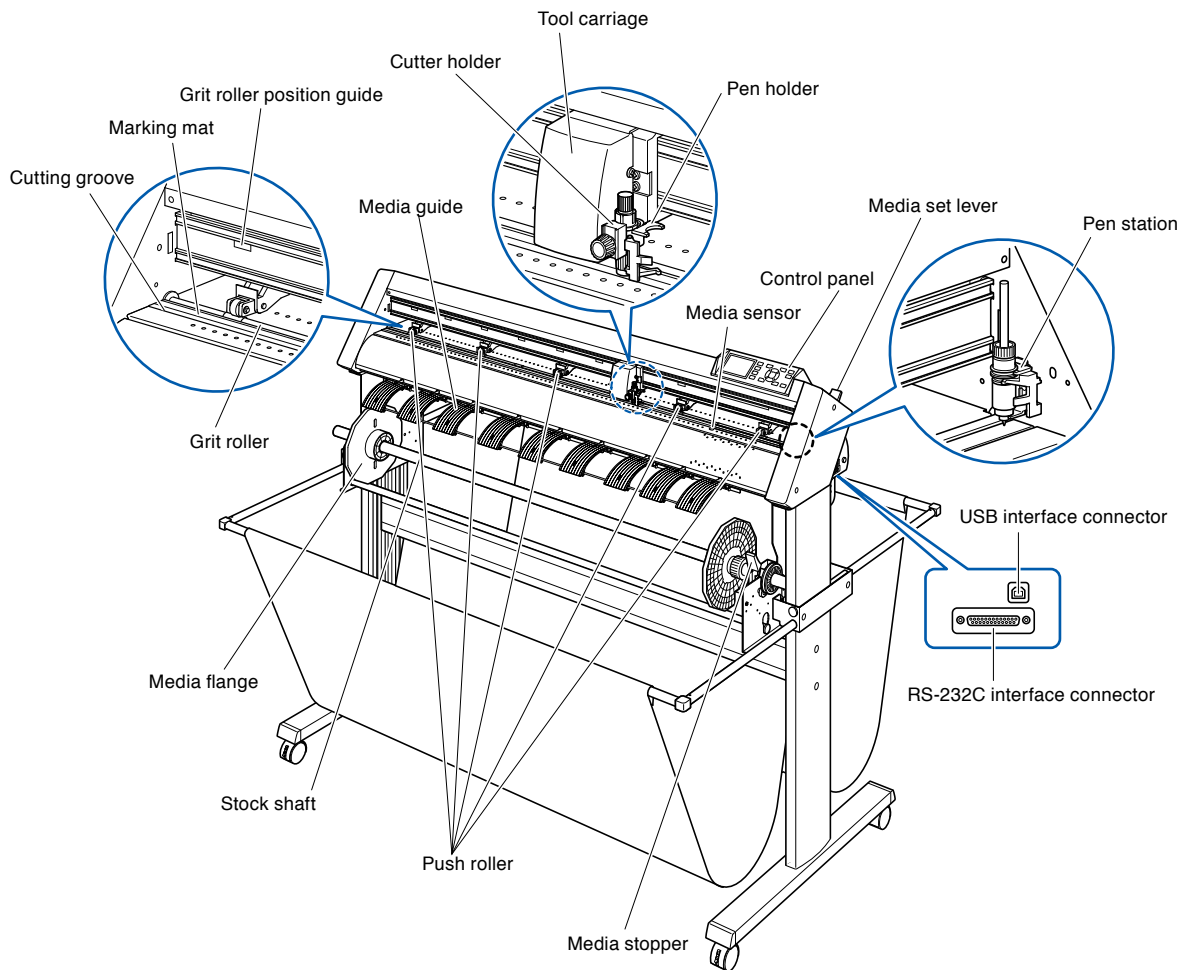

- Control panel**Used to access various plotter functions.
- Push rollers**Rollers that push the media against the grit rollers.
- Grit rollers**Metallic rollers with a file-like surface that feed the media back and forth.
- Media sensors**The front sensor is used to sense the leading edge of the media. The rear sensor is used to sense the trailing edge of the media.
- Tool carriage**Moves the cutter-pen or plotting pen across the media during cutting or plotting.
- Cutter holder**Holds the cutter in position while moving up and down.
- Pen holder**Holds the pen in position while moving up and down.
- Pen station** Fixes the pen in position before use.
- Grit roller position guide** Stickers on the front of the Y rail and the rear side of the top cover that show the position of each grit roller. Use these alignment marks as an aid in locating the Push rollers.
- Marking mat**The oil-base ballpoint moves above this and does the cutting/plotting.
- Cutting groove**Use this groove when using the media cutter.
- Media set lever**Used to raise or lower the Push rollers during the loading or unloading of media.

- USB interface connector**Used to connect the plotter to the computer with a USB interface cable.
- RS-232C interface connector** ..Used to connect the plotter to the computer with a RS-232C interface cable.
- Media stopper**.....Stops the stock shaft from rotating when the paper (media) is being set-up.
Use when pulling the (media) straight out.
- Stock shaft**.....A roller that takes in roll media.
- Media flange**Fixes the paper roll (media) in place as per settings.
- Media guide**Guides the paper (media) during the plotting/cutting process.

Rear View

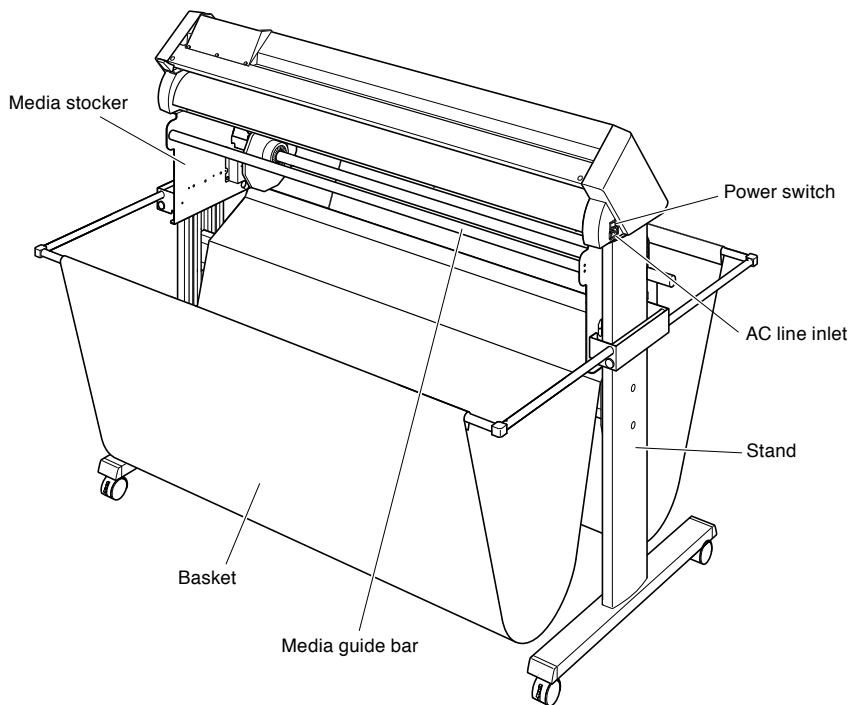

- Power switch**Used to turn the plotter on and off.
- AC line inlet**.....Inlet where the power cable is connected.
- Media stocker**The stock to set roll media in.
- Stand**A stand to put the machine on.
- Basket**The seat that holds the blank paper.
- Media guide bar**.....Shaft that used to set the roll media.

1.3

Assembling

Assemble the stand.

The stand is made up of the following parts.

Components of stand

Stand side bar L x 1
(with media stocker)

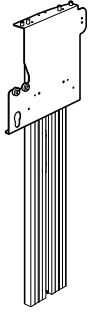

Stand side bar R x 1
(with media stocker)

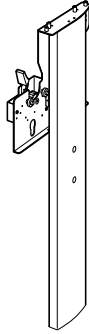

Base assembly x 2

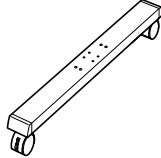

Center bar x 1

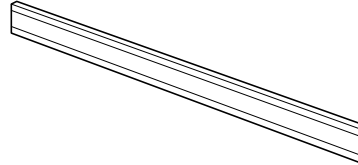

Socket head cap screw
(M5) x 22



Media flange x 2

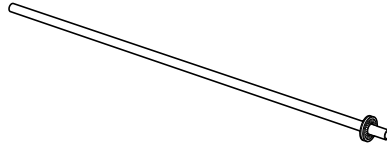

Stock shaft x 1

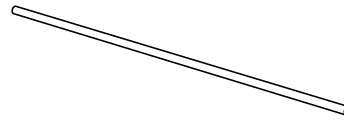

Media guide bar x 1



Allen wrench
(for M5 cap screw) x 1

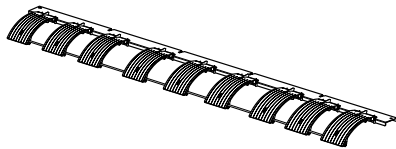

Media guide x 1

Components of basket

Sheet supporting pipe (long) x 2

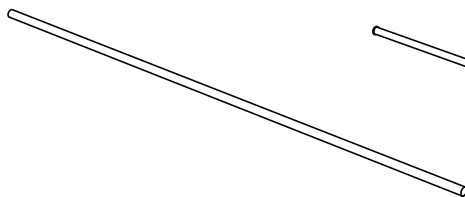

Sheet supporting pipe (middle) x 1

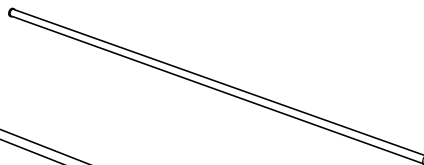

Basket x 1

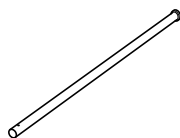
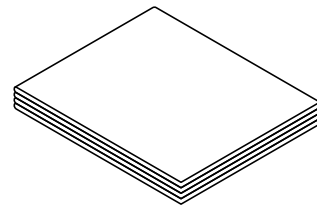

Sheet supporting pipe (short) x 4



Joint x 4



Supporting pipe plate x 2



M5 screw x 4

Assembly

CAUTION

- Please assemble with two or more people.
- People can be accidentally injured by the machine's edges. Please be very careful.
- Please be careful not to get your hands pinched or stuck when you secure the machine.

- 1** Assemble the left and right stand sides. (Attach both the left and right sides of the base assembly.)
Fasten a stand foot to each of the stand side bars with two socket head cap screws using the Allen wrench.

Supplement

- Set the stand side bar in properly so that it matches the cutout in the stand foot.
- Assemble the stand so that the front and rear lengths of the stand foot are the same for both the left and right stand sides.

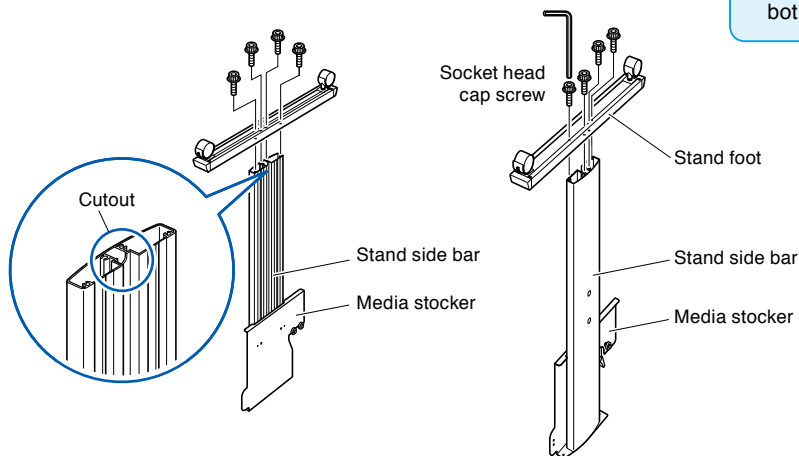

- 2** Attach the center bar to each of the left and right stand sides temporarily with two socket head cap screws, using the Allen wrench. Mount the center bar so that each one of stand feet of short side to be front side.

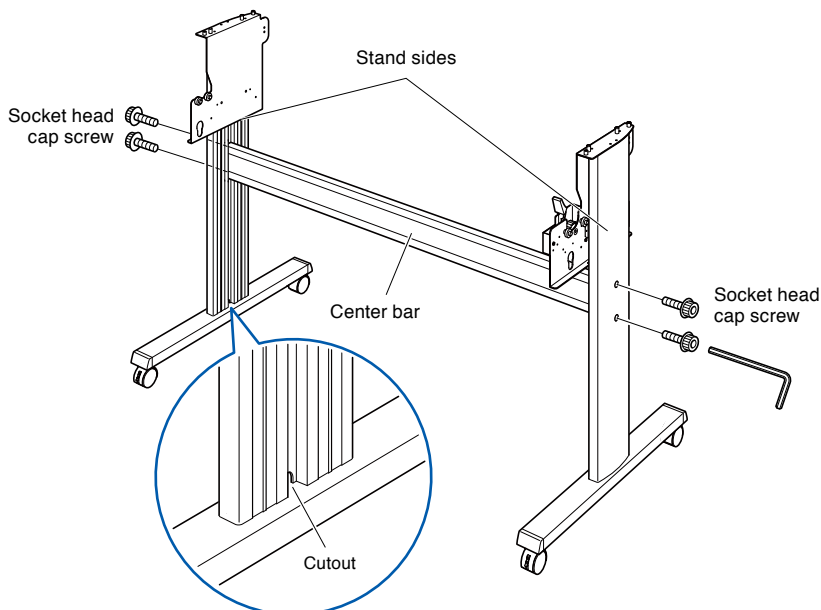

- 3 Attach the media stocker to each of the left and right stand sides with two socket head cap screws, using the Allen wrench.

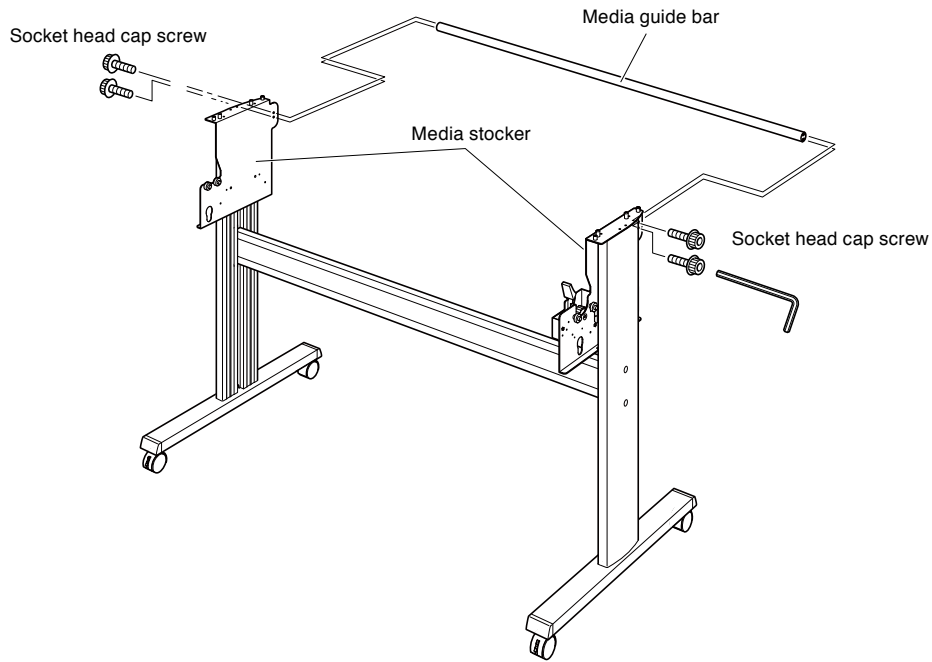

- 4 Fasten the supporting pipe plate to the left and right of the stand side bar with two screws.

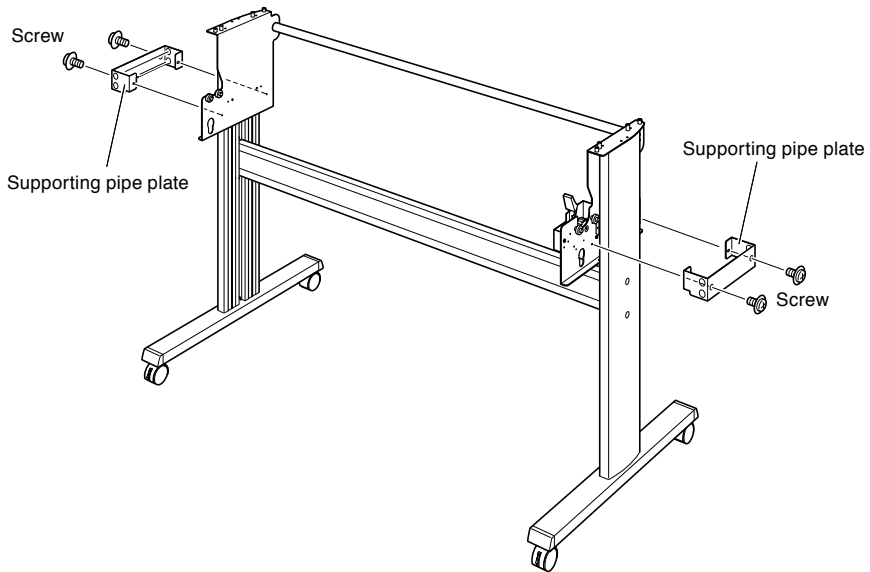

- 5** Insert the 4 short sheet supporting pipes into the supporting pipe plate from the end without an end plug.
In the front side of the main assembly insert the pipe into the upper side, and insert it into lower side in the rear side. The short sheet supporting pipe ends should now extend out from the front end of the main assembly.

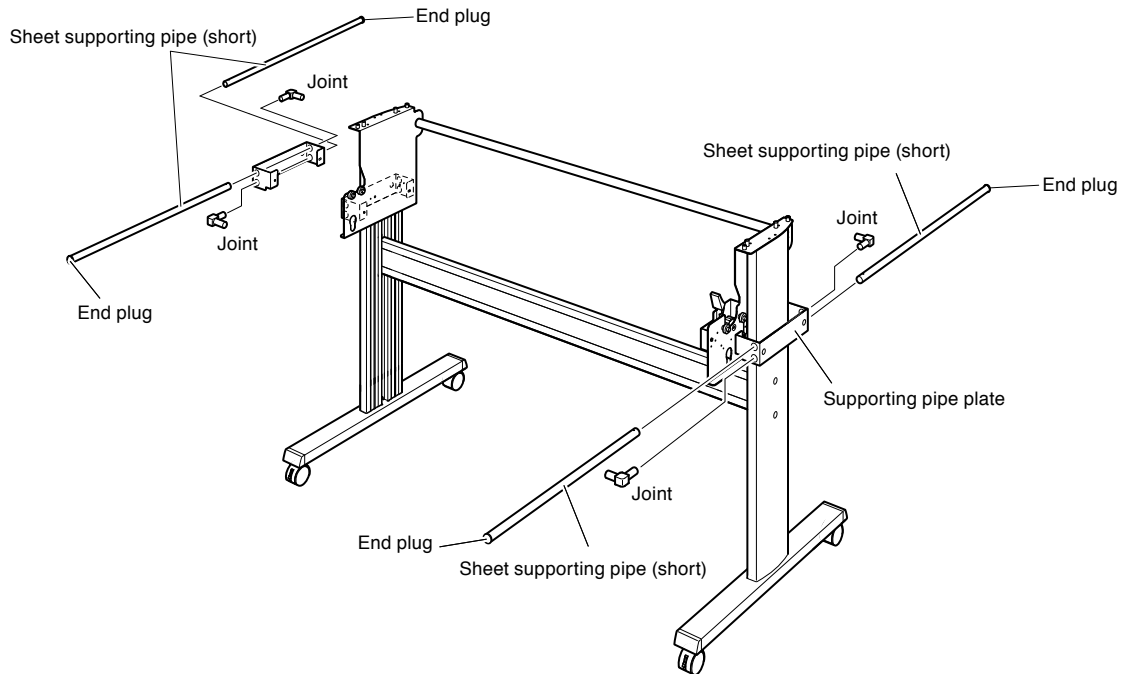

- 6** Insert one middle length sheet supporting pipe and 2 long sheet supporting pipes in to the basket.
Please insert 1 middle length sheet supporting pipe into the middle of the basket.

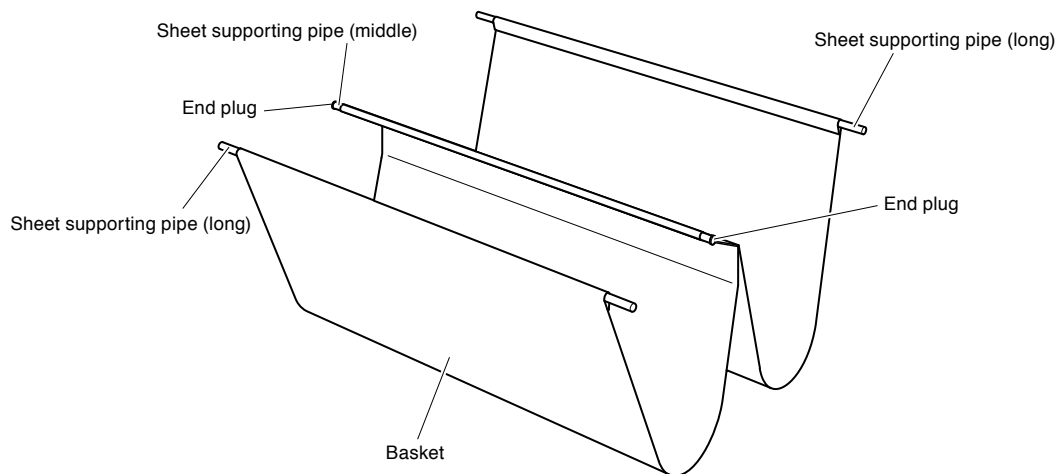

7

Using the middle sheet supporting pipe, attach the basket assembly from step 6 to the media stocker, then attach the joints from the assembly from step 5 to the long sheet supporting pipe from step 6.

The middle of the basket should pass over the back end of the center bar.

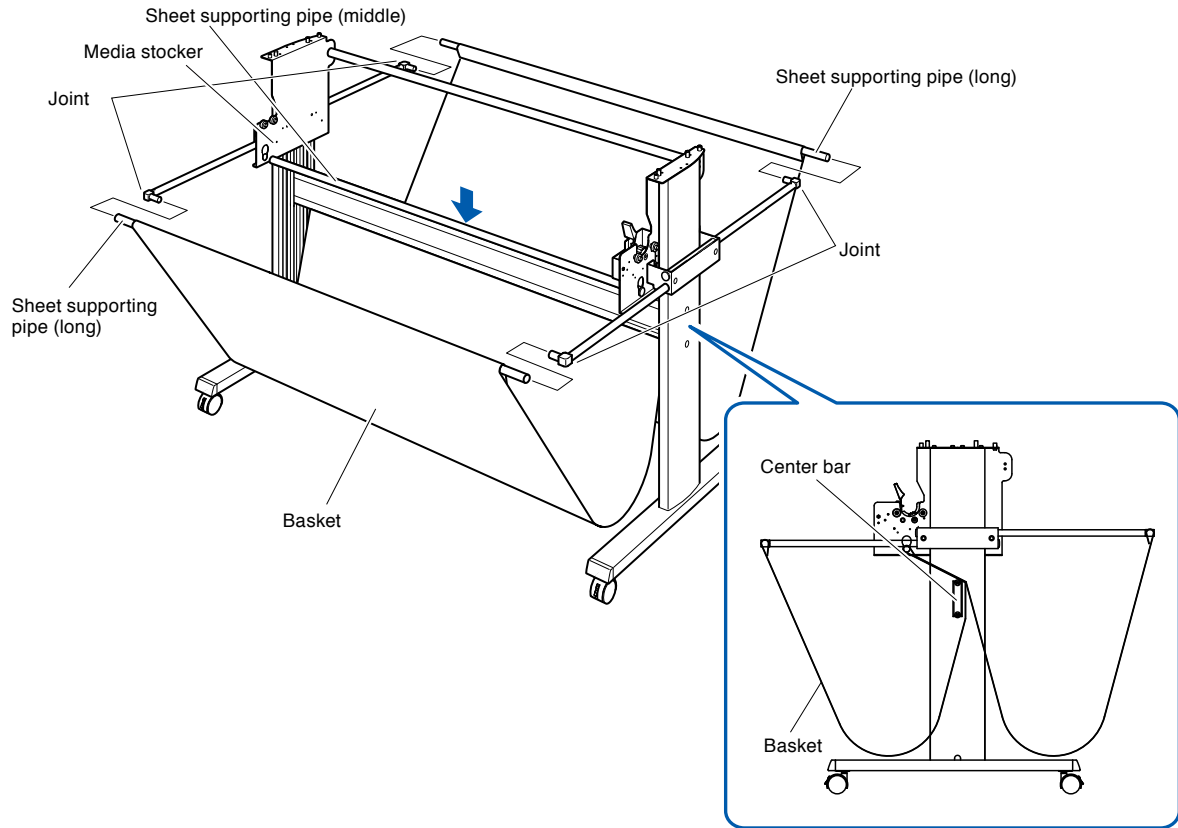

- 8 Mount the plotter on the stand by inserting the positioning pins on the stand into the positioning holes on the underside of the plotter. Fasten with four socket head cap screws (two on each side), using the Allen wrench.

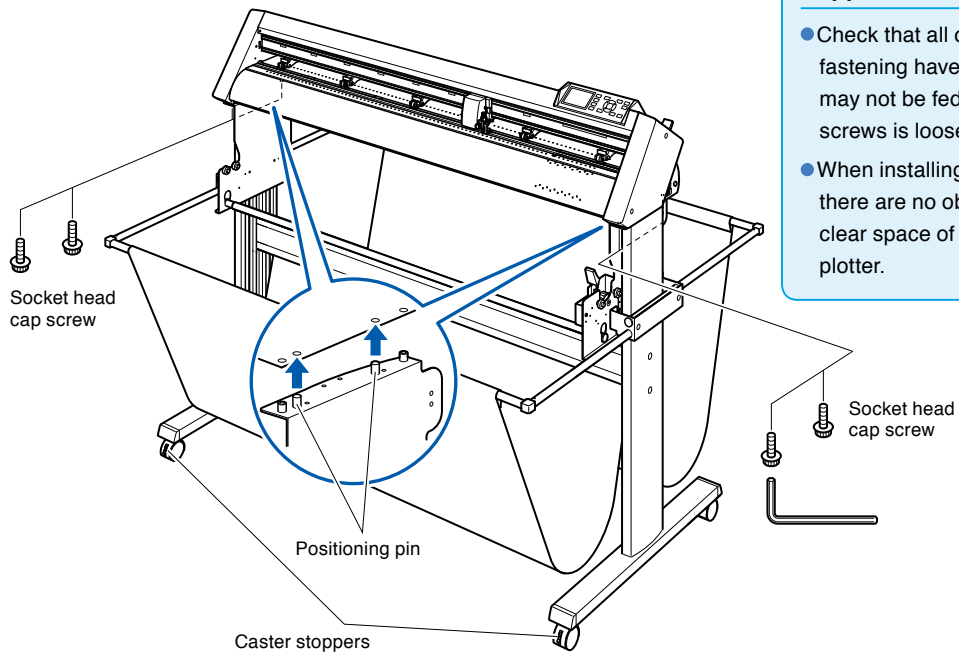

CAUTION

Please be careful not to get your hands pinched or stuck when you secure the machine.

Supplement

- Check that all of the screws used for fastening have been tightened. The media may not be fed correctly if even one of the screws is loose.
- When installing the plotter, make sure that there are no objects in its vicinity. Leave a clear space of at least 300 mm around the plotter.

- 9 Tighten the socket head cap screws loosely fastened in Step 2.

Attaching a media guide

Assembly

- 1 Insert the cut-out part of the media guide onto the components of the positioning pins at the bottom end of the main assembly. Attach both sides of the media guide using the 2 socket head cap screw.

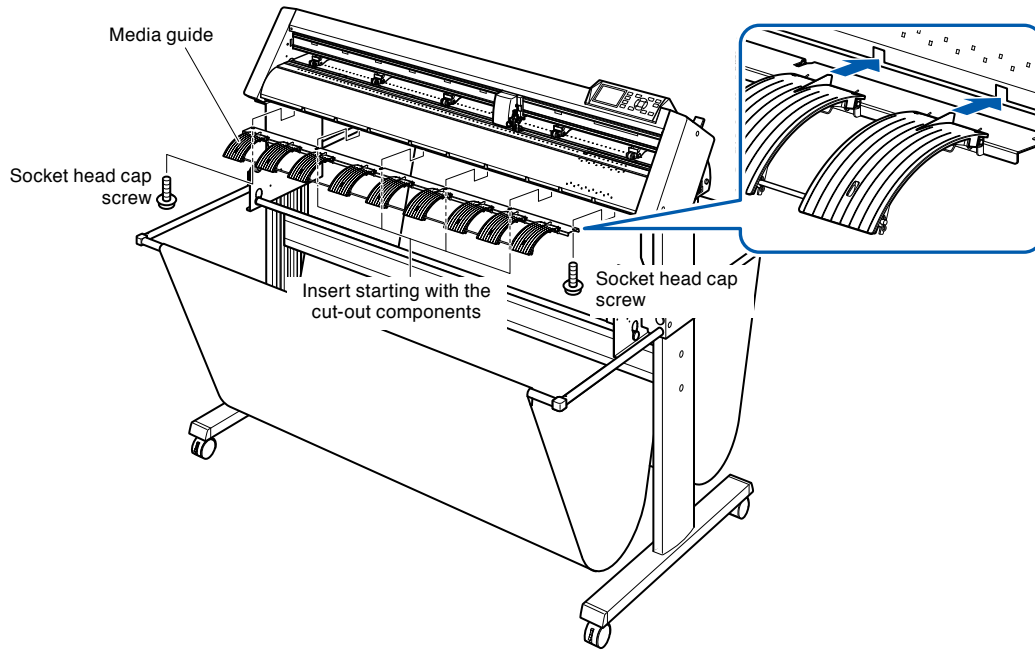

1.4

Connecting to the Computer

Connect the plotter to the computer using the interface cable. Use either the USB port, the RS-232C port to connect the plotter to the computer. Select the port depending on the specification of the software to be used and the availability of the interface port on the computer.

Please install driver software before connecting.

Depending on the port used, use either the USB cable, the RS-232C cable (CB0023C-HS: sold separately) to connect. Use the cables specified by Graphtec, matching the computer that is to be connected.

Connection

- 1 Check that the power switch is turned off (the "O" side is pressed down).

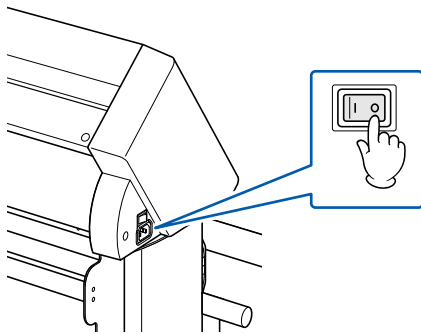

- 2 Connect the plotter to the computer using the interface cable.

Connection via USB interface

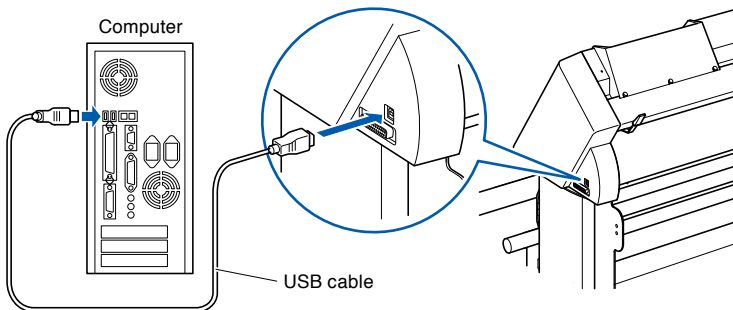

Connection via RS-232C interface

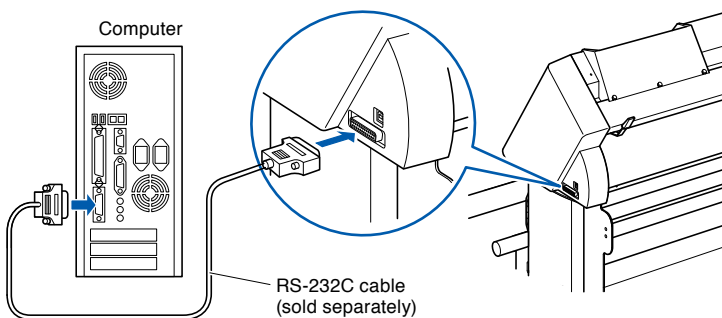

Supplement

See the "Setting Interface" [➔ P.8-2](#) about setting the interface.

Chapter 2: Preparing to Cut

This chapter describes how to prepare to start the cutting.

PRODUCT SUMMARY

- 2.1 Preparation of Cutter Plunger**
- 2.2 Attaching a Tool**
- 2.3 Loading Media (Paper)**
- 2.4 Aligning the Push Rollers**
- 2.5 About the Default Screen**
- 2.6 Connecting to the Power**
- 2.7 How to Use Control Panel**
- 2.8 Setting Feeding Method**
- 2.9 Auto media transfer and cross cut**
- 2.10 Selecting Tool Condition**
- 2.11 Setting Cut Line Pattern**
- 2.12 Running Cutting Tests**
- 2.13 About Simple menu**
 - 2.13.1 Setting Page Length (Simple mode)**
 - 2.13.2 Setting the number of pre feeds (Simple menu)**
 - 2.13.3 User selection settings (Simple menu)**
 - 2.13.4 Setting RS-232C interface (Simple menu)**
 - 2.13.5 Display Length Unit Settings (Length Unit) (Simple menu)**

2.1

Preparation of Cutter Plunger

This chapter describes the structures and types of the putter plungers (cutter pens).

Cutter Plunger Nomenclature

The plotter cuts using a cutter blade mounted in a plunger. There are two different plungers to suit the diameter of the cutter blade to be mounted (the $\phi 0.9$ mm cutter plunger is provided as a standard accessory). Be sure to mount the cutter blade in the corresponding cutter plunger.

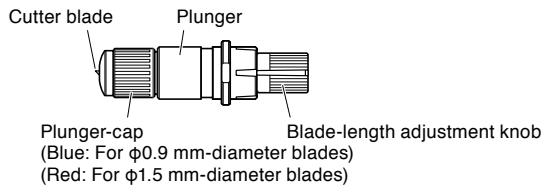

CAUTION

To avoid bodily injury, handle cutter blades with care.

Structure of Cutter Plunger

$\phi 0.9$ mm diameter cutter Plunger

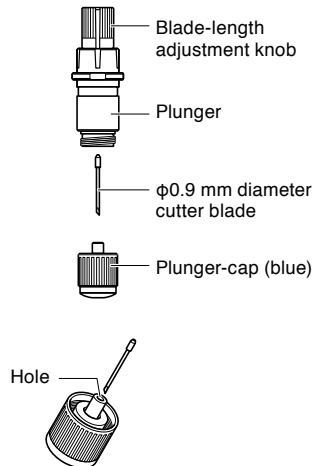

$\phi 1.5$ mm diameter cutter Plunger

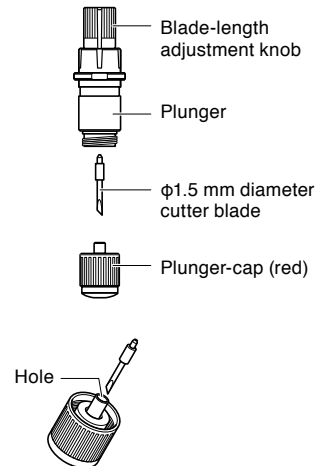

Adjusting the Blade Length

Blade length needs to be adjusted to perform optimal cut. Perform few test cuts and set the optimal blade length.

CAUTION

- To avoid bodily injury, handle cutter blades with care.
- It may result in damaging the cutter blade or the cutting groove if the blade is extended too much.

Supplement

- For the test cut, see "Running Cutting Tests" [P.2-41](#).
- For method to manually adjust the blade length, see "Adjust the Blade Length" [P.2-37](#).

Adjust the blade length by turning the blade-length adjustment knob. Turn the knob in direction "A" to extend the blade, or in direction "B" to retract the blade. When the knob is turned by one scale unit, the blade moves approximately 0.1 mm. One full turn of the knob moves the blade approximately 0.5 mm.

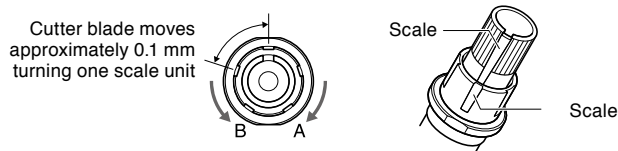

Blade Application and Features

Select the optimal cutter blade and medium to be cut.
Refer to the Cutter Blade Manual.



CAUTION

To avoid bodily injury, handle cutter blades with care.

2.2

Attaching a Tool

Attach a tool (cutter plunger, plotter pen) to the plotter.

Attaching a cutter plunger

When mounting the cutter plunger in the tool holder, please note the following.

- Push the cutter plunger all the way into the holder until its flange contacts the upper part of the cutter holder and then tighten the screw firmly.
- To prevent injury; avoid absolutely touching the cutter plunger immediately after the cutting plotter is turned on or whenever the cutter plunger is moving.

The cutter holder is suitable only for use with the cutter plunger. Please refrain from attaching the plotting pen to it.

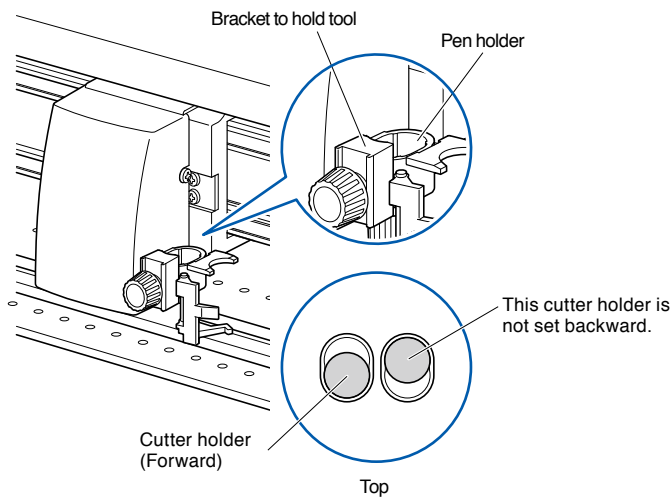

CAUTION

When pushing the cutter holder with your fingers, the blade tip may be protruding. Take care not to cut your fingers.

Supplement

Please make certain to set the cutter plunger of the cutter holder (forward).

Mounting

- 1 Loosen the cutter holder screw.

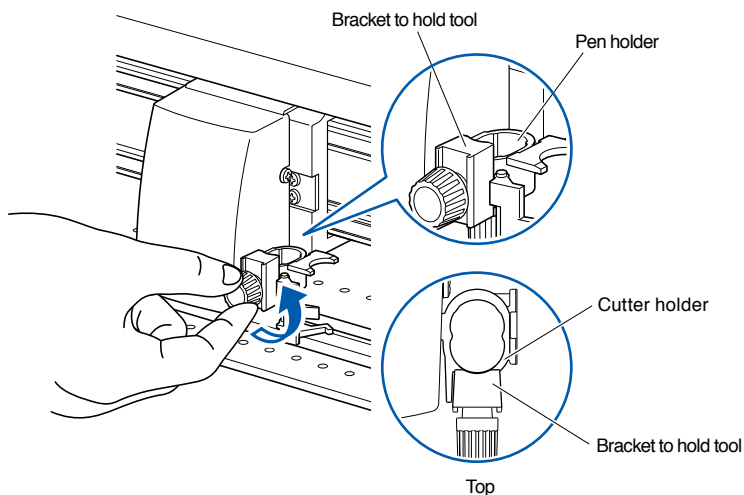

- 2 While pushing up the cutter holder, push until its flange completely touches the upper part of the cutter holder.

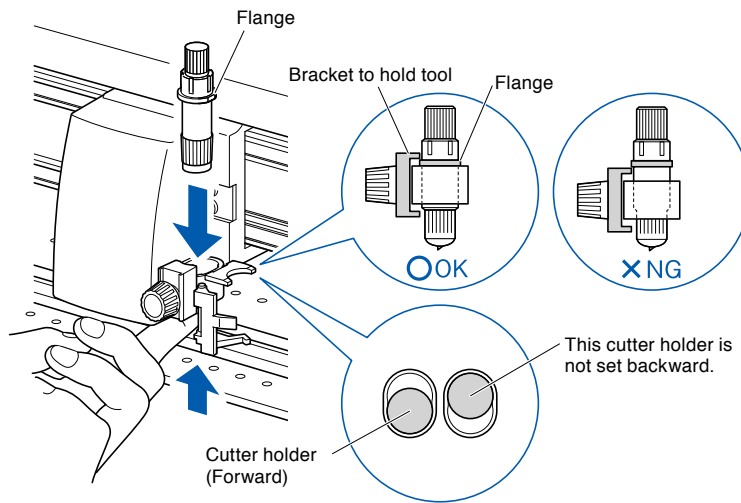

Supplement

Set the tool in the cutter holder (forward).

- 3 Make sure that the tool bracket is engaged on the cutter plunger's flange, and then tighten the screw.

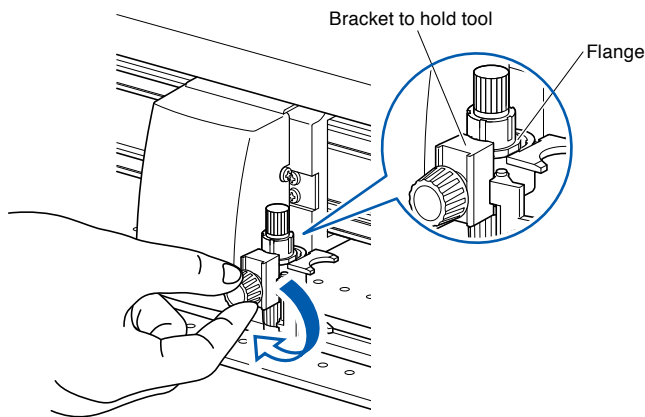

Removing the cutter plunger

When removing the cutter plunger, turn it counterclockwise to remove the cutter plunger.

Attaching a pen

Attach a pen to the pen station.

- Please make sure to attach the pen to the pen station when setting up a pen.
- To prevent injury, avoid touching the pen immediately after the cutting plotter is turned on or whenever the pen is moving.

Operation

1. You can attach the pen by opening up the holder on the pen station with your finger.

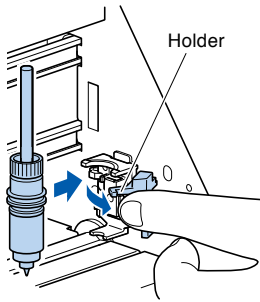

2. Once the pen is attached, releasing the holder fixes the pen in place.

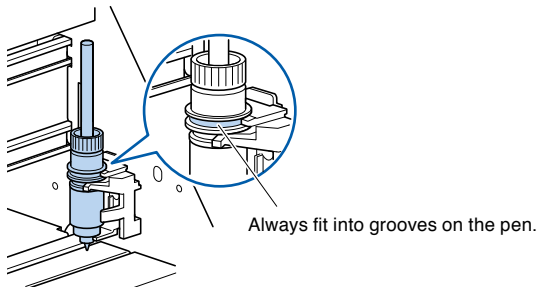

Supplement

Make sure to check that the top part of any tools mounted on the pen station is set in the grooves above the pen.

Removing a pen

You can remove the pen by lifting up the holder.

2.3

Loading Media (Paper)

Both roll media and sheet media can be used with the CE6000-120AP. Load the media according to the instructions given for each type.

Use the grit roller on the right side of the media (looking from the front) as a guide when setting it in the media sensor. Afterwards, adjust the push roller so that it's lined up with the side of the media.

➔ P.2-7 Setting Roll Media

➔ P.2-14 Loading Sheet Media

⚠ CAUTION

Notes when using roll media

- Make sure to reduce the maximum feed rate if there is any trouble with paper feed not using the basket.
- Take all cut/plotted paper out of the basket; paper left in the basket may cause deviations and affect performance for subsequent jobs.

Loading Roll Media

Operation

- 1 Set the media flange and paper to the stock shaft and insert in the direction of the paper.

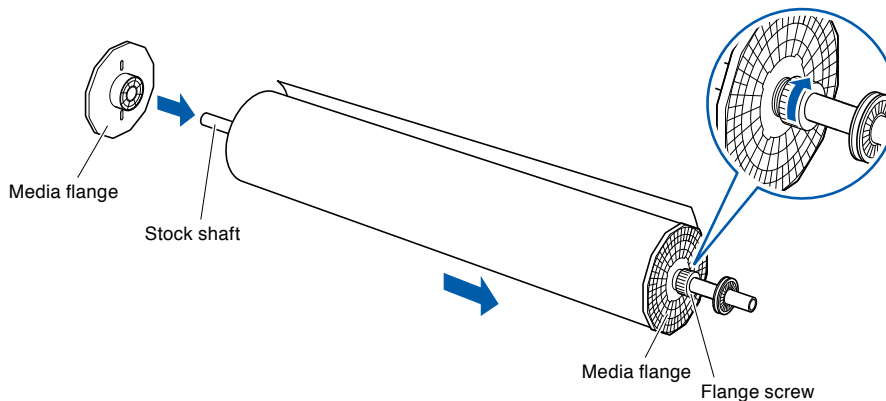

Supplement

When installing, place the paper roll as follows:

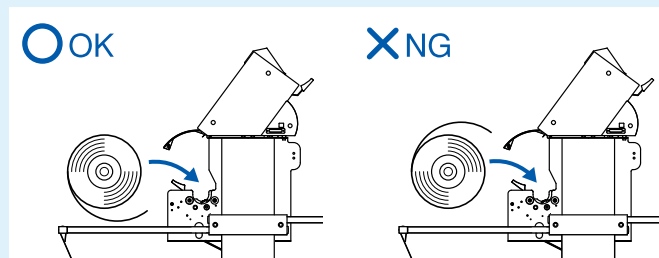

Determine the desired position, and then tighten the flange screw. Set the position measurement for the media flange as per the following guidelines in when using paper with a width of 1200 mm. If using paper of a different width loosens the flange screw, adjust the position of the grit roller, then re-tighten the flange screw.

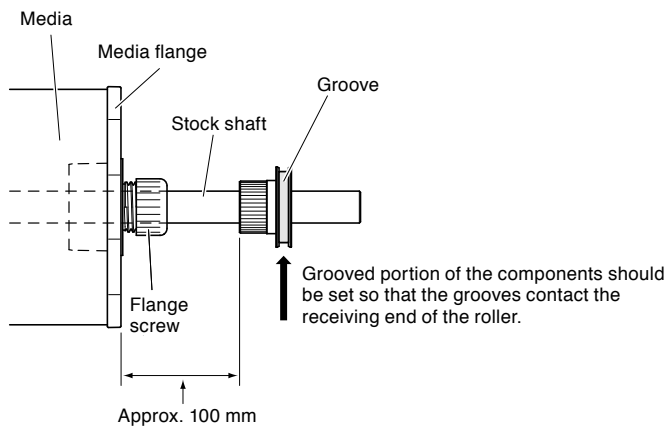

2 Lowering the lever releases the stopper lock.

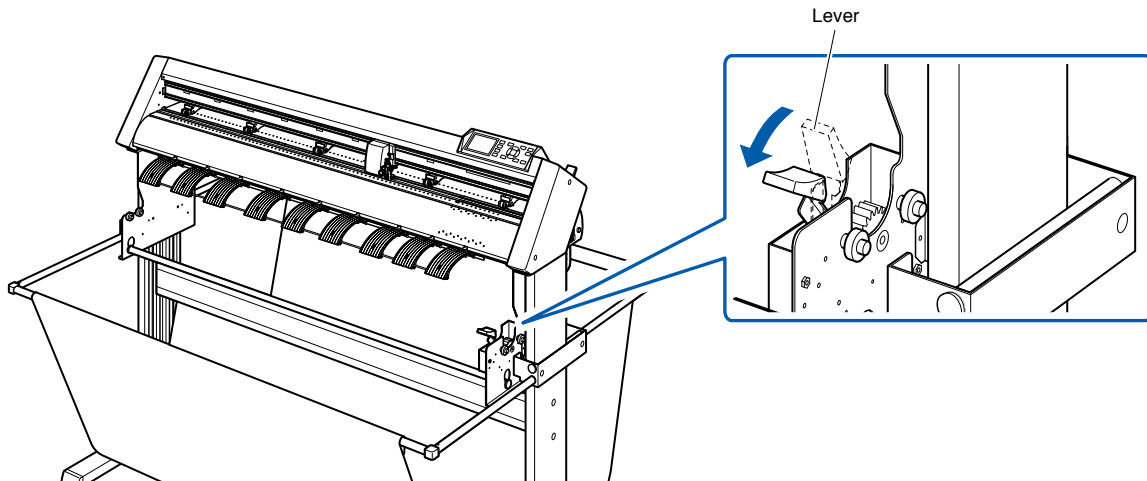

3 Set the stock shaft in from the front.

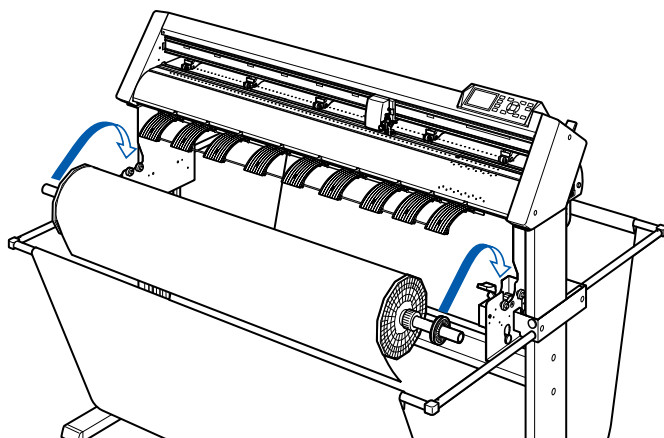

Align the receiving end of the media shaft with the grooves on the roller and push down firmly to set it in place.

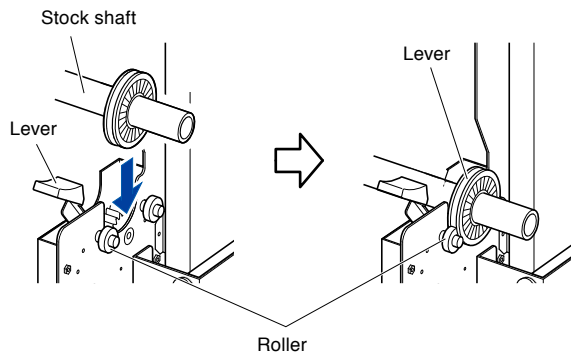

CAUTION

- During a plotting or cutting operation, be sure to keep your hands, hair, and so forth away from the media stocker, gears and rollers.
- When you are installing media, be careful for gear, a roller, etc. not pinch your finger.
- Deviations and errors may result if the stock shaft is misaligned when plotting begins.

Please make sure to set in the direction of the paper.

○OK

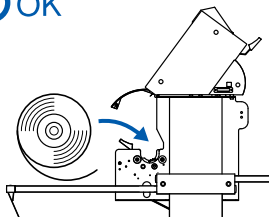

✗NG

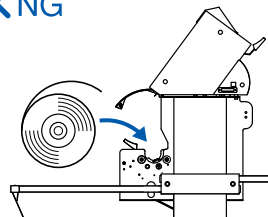

- 4 The left and right media flanges feed in the paper roll media. Please tighten the flange screw and fasten the paper roll into the desired position.

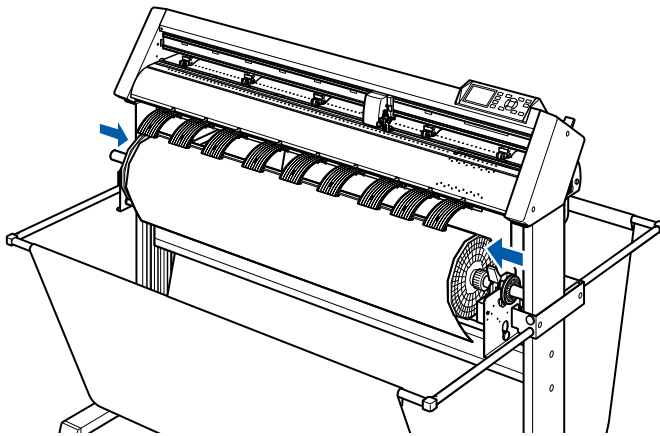

- 5 Lower the media set lever to raise the push rollers.

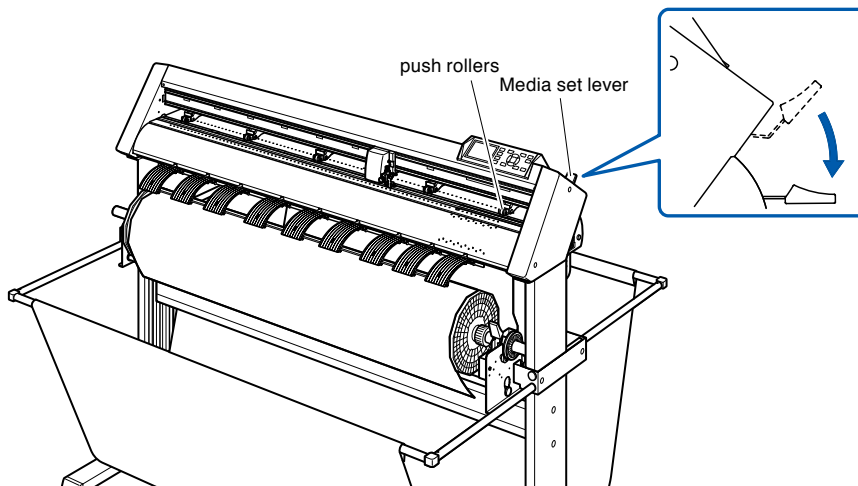

6

Put the roll media on the roll media tray and then push the tip of the roll media forward from the back of the machine. Make sure to pull it so that there is no slacking across the roll media's route.

Supplement

- The media must always be positioned over the media sensor.
- See "2.4 Aligning the Push Rollers" [➔ P.2-16](#) about the position of the push rollers.

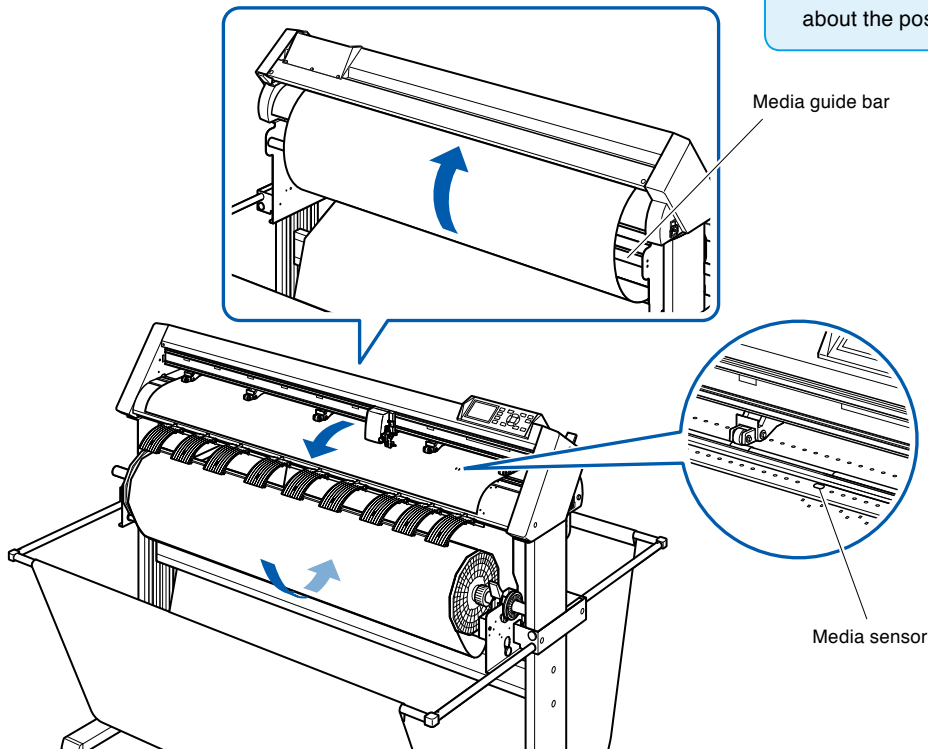

The paper roll media's route goes over the center bar and behind the media guide bar.

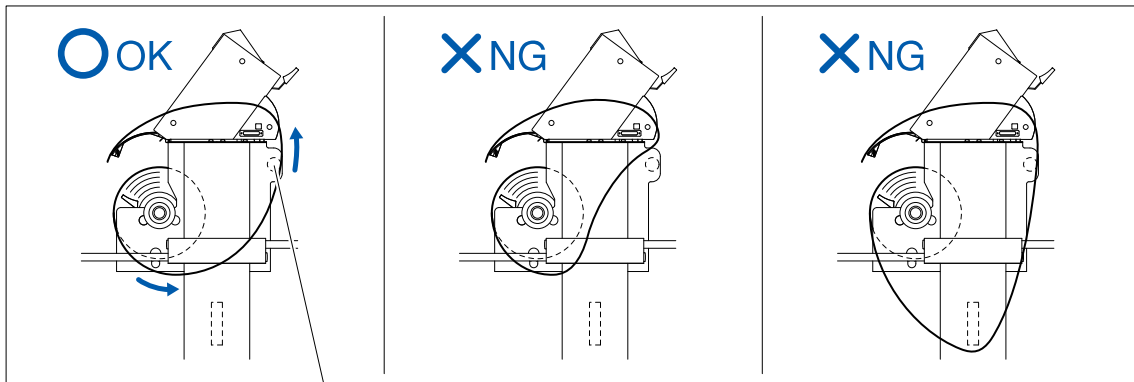

Media guide bar

7

Position the media and the push rollers to correspond with the width of the media.

Use the 5 push rollers to push down the sides and center of the media. Use the grit roller position guide and make sure the push rollers are on top of the grit rollers.

Use the grit roller position guide to make sure the push rollers are set on top of the grit rollers.

You can adjust the center push roller's hold-down force.

Supplement

- The media must always be positioned over the media sensor.
- See "2.4 Aligning the Push Rollers" → P.2-16 about the position of the push rollers.
- See "2.4 Aligning the Push Rollers" → P.2-16 for information about center 3 push roller hold-down force.

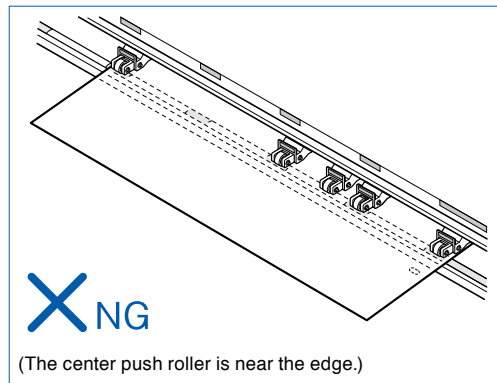
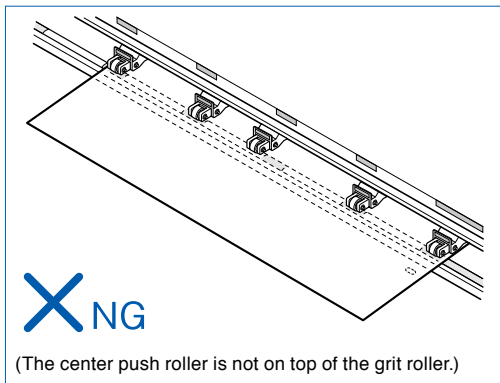
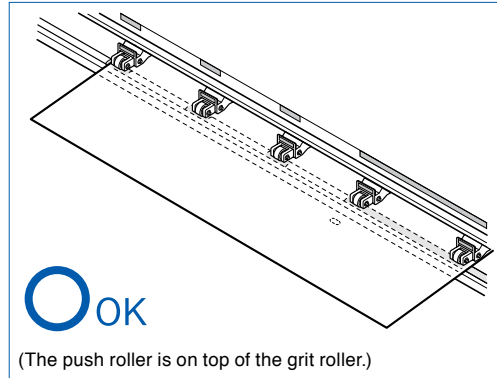
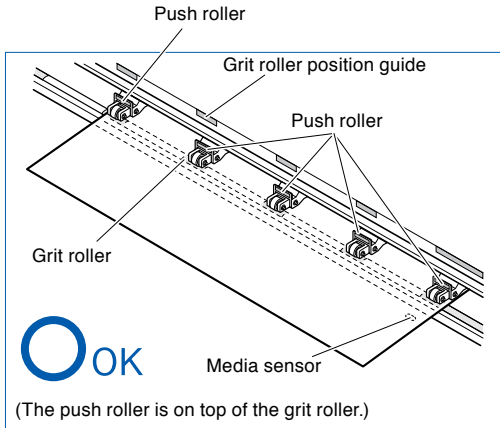

When Feeding Long-axis Media (at exceeds 2 meters)

Position the push rollers at least 15 mm inside the edges of the media.

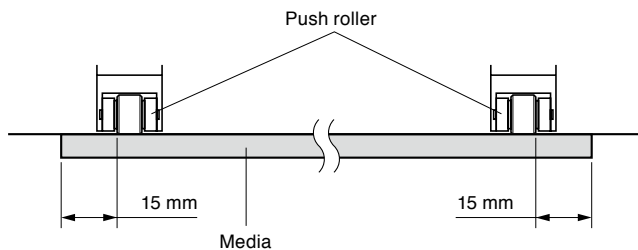

CAUTION

When setting on inside more than 30mm, cut cross is not available.

When Feeding Long-axis Media (at least 2 meters)

Position the push rollers at least 5 mm inside the edges of the media.

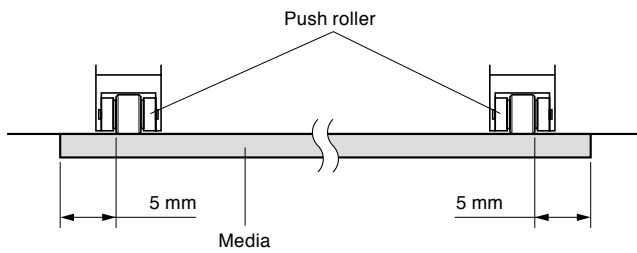

CAUTION

When setting on inside more than 30mm, cut cross is not available.

8 Raise the lever to lock.

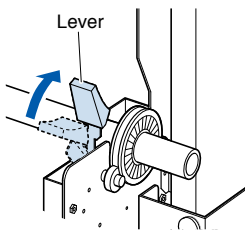

CAUTION

During a plotting or cutting operation, be sure to keep your hands, hair, and so forth away from the media stocker, gears and rollers.

9 When removing the paper, please stand to the side of the main assembly and pull horizontally from the middle of the paper.

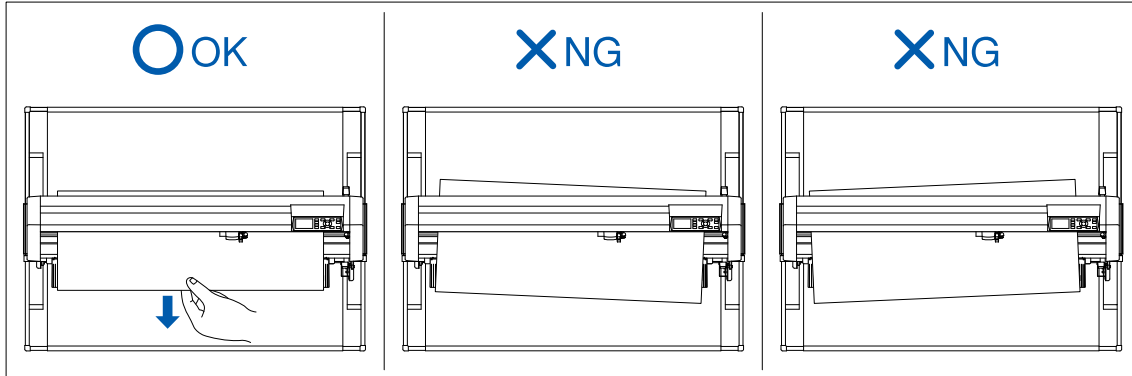

- 10 Pull from the front of the machine to even the tension of both A and B sides of the paper, as shown in the figure below.

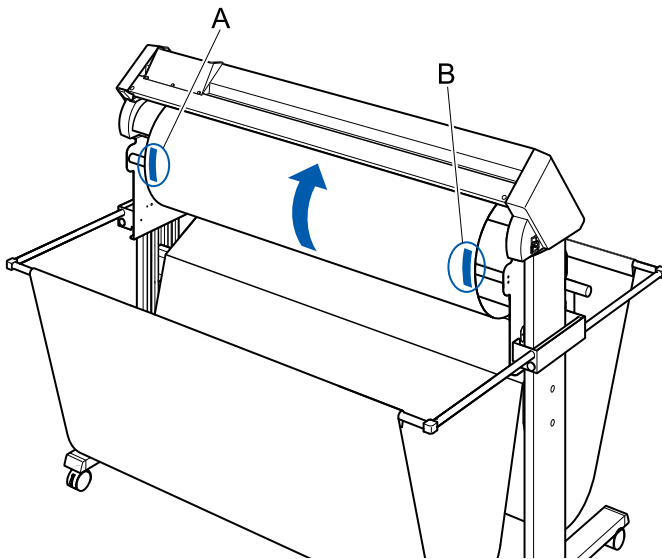

- 11 Raise the set lever after confirming that the route the roll paper passes through is taut and not slackening. The push roller position and the roll paper will stay in place.

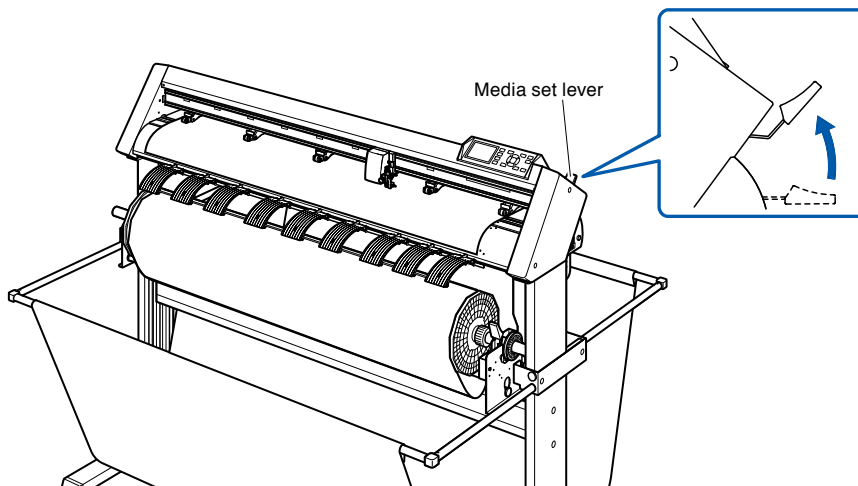

- 12 Lowering the lever releases the stopper lock.

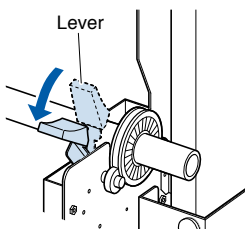

CAUTION

During a plotting or cutting operation, be sure to keep your hands, hair, and so forth away from the media stocker and collar.

Loading Sheet Media

Operation

- 1 Lower the media set lever to raise the push rollers.

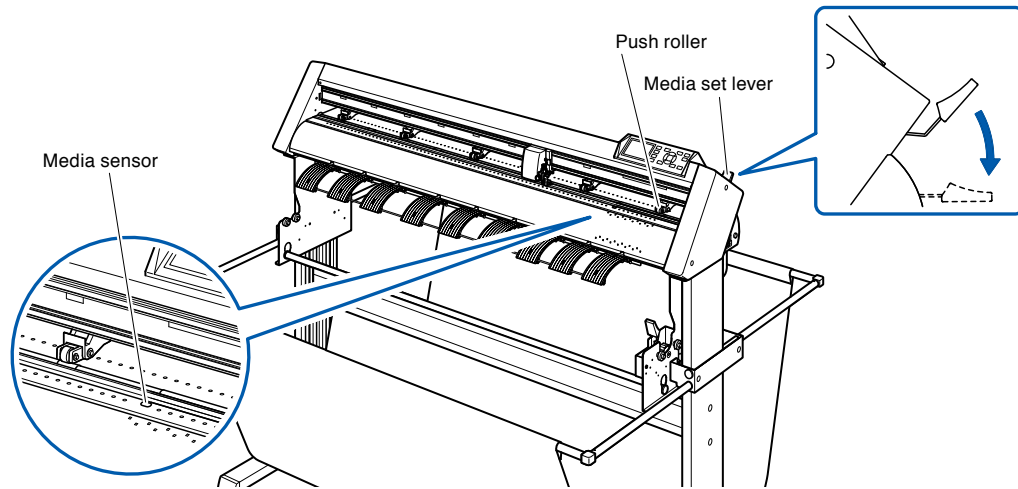

- 2 Make sure that the sheet media completely covers the media sensor.

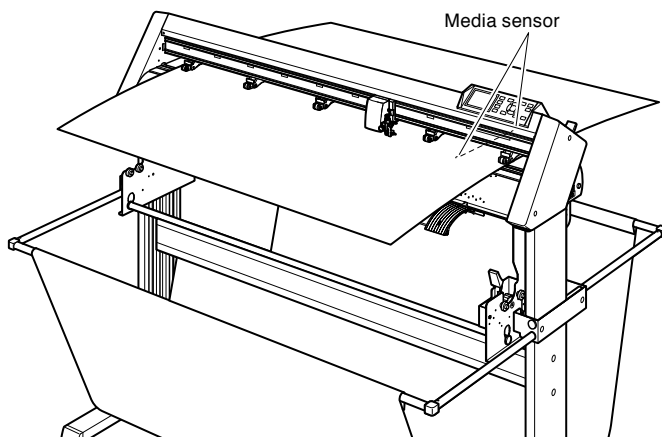

3

Position the media and the push rollers to correspond with the width of the media.

Use the 5 push rollers to push down the sides and center of the media. Use the grit roller position guide and make sure the push rollers are on top of the grit rollers.

Use the grit roller position guide to make sure the push rollers are set on top of the grit rollers.

You can adjust the center push roller's hold-down force.

Supplement

- The media must always be positioned over the media sensor.
- See "2.4 Aligning the Push Rollers" → P.2-16 about the position of the push rollers.
- See "2.4 Aligning the Push Rollers" → P.2-16 for information about center 3 push roller hold-down force.

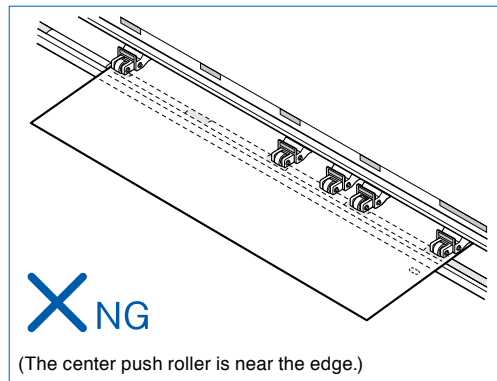
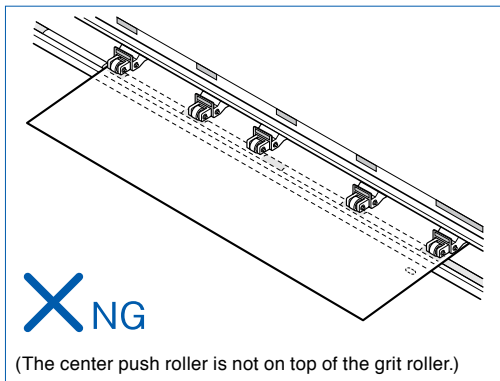
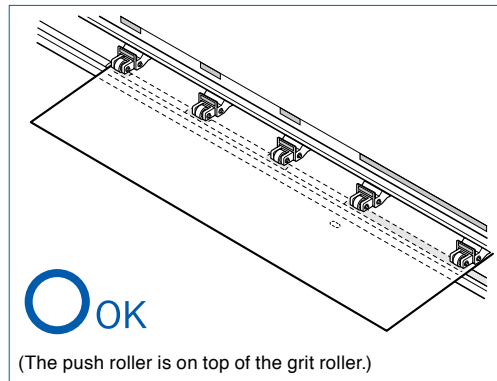
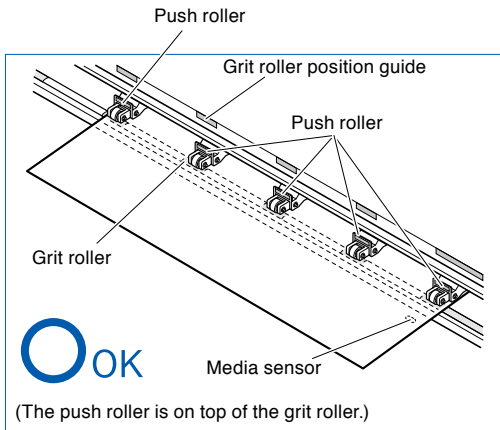

4

Straighten and align the end of the paper using the holes above and below the media guide as a reference point.

Raise the set lever after confirming there is no slackening to secure the sheet paper and push roller position.

Supplement

Please ensure that the media passes over the media sensor.

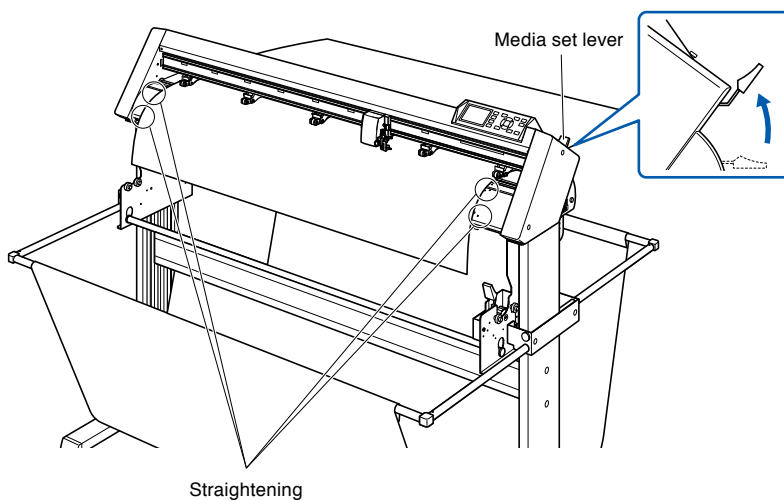

2.4

Aligning the Push Rollers

This section describes how to alignment of the push rollers.

Aligning the Push Roller

Position the left and right push rollers to correspond with the width of the media. Adjust the push rollers so that they are positioned above both the media and the grit rollers.

All the push rollers should come above the grid rollers.

Position the push rollers within the grit roller position guides ensures that they are above the grit rollers.

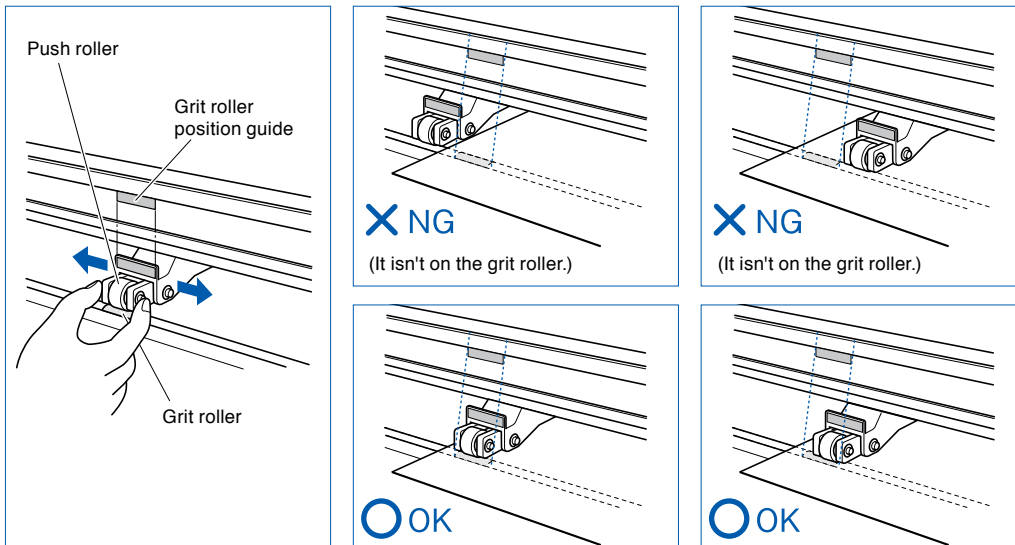

CAUTION

To move the push rollers, the media set lever must be in the lowered position.

Supplement

If a [confirming push roller point] message appears after setting the media and raising the set lever, it means the right push roller is not set on the long right grit roller, or that the left or center 3 push rollers are not set on the proper grit roller. Make sure everything is set correctly.

When Feeding Long-axis Media (at exceeds 2 meters)

Position the push rollers at least 15 mm inside the edges of the media.

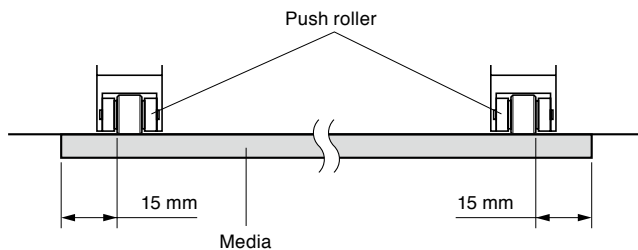

CAUTION

When setting on inside more than 30mm, cut cross is not available.

When Feeding Long-axis Media (at least 2 meters)

Position the push rollers at least 5 mm inside the edges of the media.

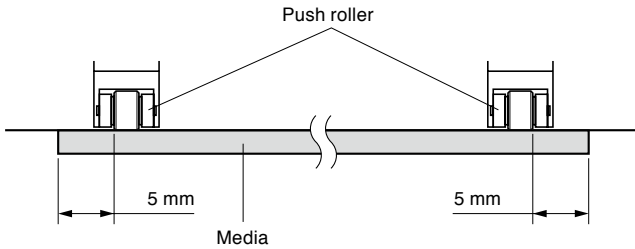

CAUTION

When setting on inside more than 30mm, cut cross is not available.

To use a paper wider than 1,119 mm

Carefully set the position of the left edge of the push roller.

Set the right edge of the grit roller between 2 mm and 8 mm.

It's not possible to set the right edge of the grit roller to a size greater than 8 mm. (There is a stopper.)

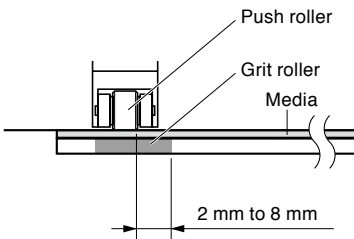

CAUTION

Notes on the left grit roller

- The left grit roller is not available in all locations.
- It's not possible to set the right edge of the grit roller to a size greater than 8 mm. (There is a stopper.)
- Please set the push roller to the position between 2 mm and 8 mm from the right edge of the grit roller.

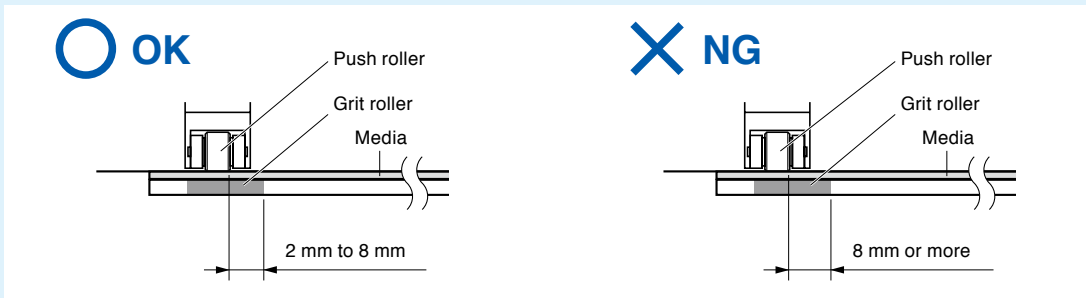

For minimum width media

The CE6000-120AP can take media of 594 mm (A1 size) or more.

CAUTION

- The media must be at least 125 mm in length in media feed direction.
- The media must always be positioned over the media sensor.

Changing the Hold-down Force

The down force applied by the middle 3 push rollers can be changed depending on the width and type of media used.

When using the genuine Graphtec paper, please set the force of the middle push roller to "Normal" and the remaining 2 rollers to "Low" (OFF).

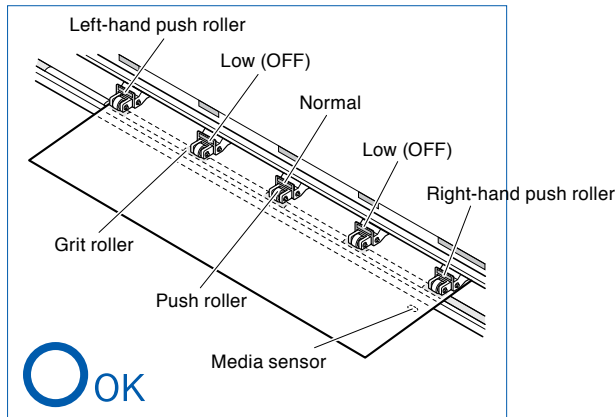

Switching

- (1) Lower the media set lever to raise the push rollers.
- (2) Use the push roller hold-down force switching lever on the back of the push roller to adjust the center push roller's hold-down force. It can be set to Normal or Low (OFF).
- (3) When the push roller hold-down force switching lever is up, it is in Normal mode. When it is down, it's Low (OFF).

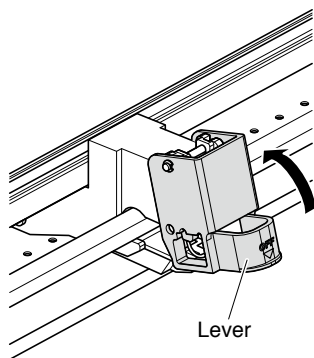

Hold-down force: Normal

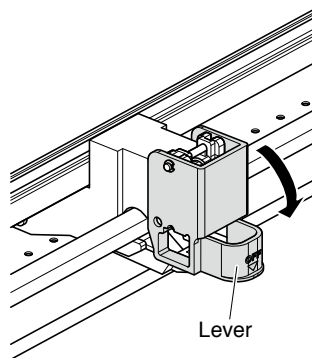

Hold-down force: Low (OFF)

CAUTION

Hold-down force can not be switched for side push rollers.

Supplement

Switch the hold-down force as necessary for different types of media.

2.5

About the Default Screen

The Initial Setup Screen appears only when powering up the machine for the first time after purchase. Here, you can set the display language and length unit.

You can also enter the menu select from the READY status after a setup.

➡ P.9-2 Display Language Settings (LANGUAGE SELECTION)

➡ P.9-3 Display Length Unit Settings (LENGTH UNIT)

See "2.6 Connecting to the Power" ➡ P.2-20 for turning on the power.

Operation

- 1 Once the machine is powered on (with the "I" switch) a message will be displayed after the version is displayed.

▶ Here, PLEASE DISPLAY LANGUAGE setting screen is displayed.



- 2 Use the POSITION (▲▼◀▶) keys to select the language. (This manual assumes you chose the English language setting.)

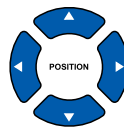

- 3 Press the [ENTER] key.

▶ After the DISPLAY LANGUAGE is selected, the LENGTH UNIT screen will appear.

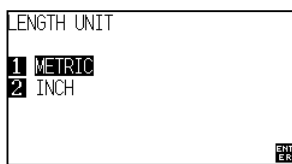

- 4 Press the [1] key (METRIC) or the [2] key (INCH) to select the length unit setting.

- 5 Confirm the setting and press the [ENTER] key (SET).

▶ Setting will be set, and it will return to default screen.

Supplement

The default value for the command setting is HP-GL, and the origin position is lower left.

2.6

Connecting to the Power

Turning on the power of the plotter.

Operation

- 1 Check that the power switch is turned off. (the "O" side is pressed down)

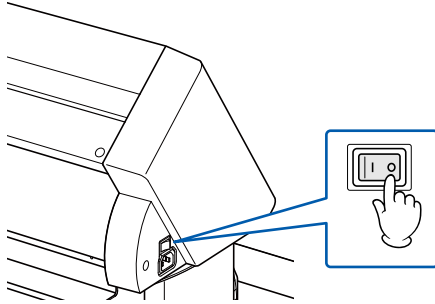

- 2 Connect one end of the provided power cord to the CE6000-120AP AC line inlet and the other end to an electrical socket of the rated supply voltage.

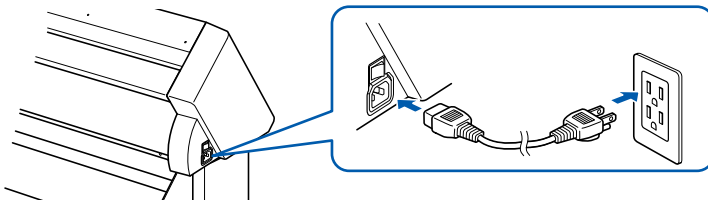

- 3 Turn on the CE6000-120AP by pressing the "I" side of the switch. LCD on the control panel is lit.

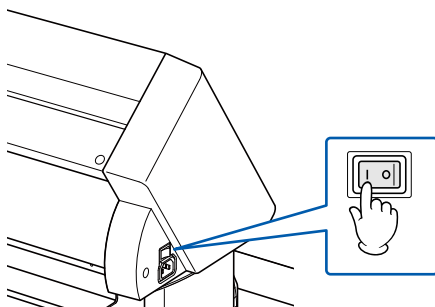

- 4 If media has not been loaded, the firmware version number is displayed, followed by a prompt to load media.

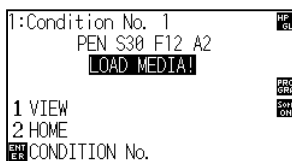

Media set lever raised
(The push roller is up)

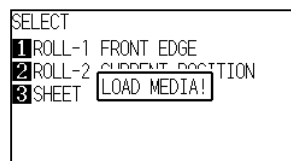

Media set lever lowered
(The push roller is down)

Supplement

When turning the power off, wait over 20 seconds before turning it on again, otherwise problems may occur with the display.

Supplement

- The Default Screen will appear after purchasing the machine. See "2.5 About the Default Screen" [→ P.2-19](#) for more information.
- This screen is described as "default screen" in this document.
- Settings such as initial media feed speed and communication conditions can be performed.

2.7

How to Use Control Panel

This section explains the function of lamps and keys on the control panel.

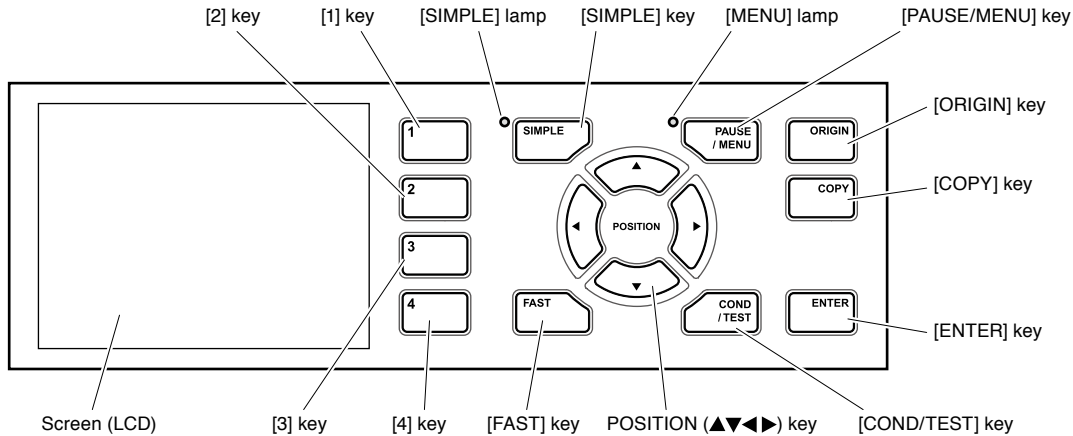

Control Keys

POSITION (▲▼◀▶) key

..... There are following functions depending on the operation.
Move the tool carriage and media. It will move specified distance (see "Setting of Step Movement Distance" → P.3-4) when it is pressed once, and continuously move when it is pressed down. It will select the menu when ▲▼◀▶ are displayed in the menu on the screen.

FAST The tool carriage or the media will move faster when it is pressed simultaneously with POSITION key.
It will work as a menu key when it is displaying "FAST" on the screen. Press the [FAST] key during READY status to display the current area and tool carriage position.

ORIGIN It will set the current position as an origin point.
On the default screen, pressing the [ENTER] and [ORIGIN] keys at the same time will allow you to reset the machine. (Only in Normal menu)

COPY Copy of data in the buffer memory is output.

Menu Keys

SIMPLE The switch between Simple menu and Normal menu can be performed on the default screen.

PAUSE/MENU It will switch to the MENU mode. MENU lamp is lit in the MENU mode.
It will go into MENU mode if it is pressed once, and MENU mode will be turned off when it is pressed again.
Different function are set in the MENU mode.
Data received while in the MENU mode will be stored in the data buffer.

COND/TEST It will display the screen to set the tool conditions.
Use this when checking tool conditions to activate a cutting test.

1, 2, 3, 4 Select the menu number displayed in the screen.

ENTER It will define the settings.
Press the [ENTER] and [ORIGIN] keys simultaneously on the default screen to reset the machine.

Indicator Lamp

SIMPLE lamp A green light indicates Simple menu is on.

MENU lamp A green light indicates MENU mode is on.

Reading the Screen (LCD)

Information reflecting the status will be displayed in the screen of the control panel.

Name of the button and corresponding function is displayed on the screen when a function is allocated to the button on the control panel. Button name will be displayed in reverse when the button is enabled.

Following items are displayed in the default screen.

This instruction manual will use Normal menu screens to demonstrate everything.

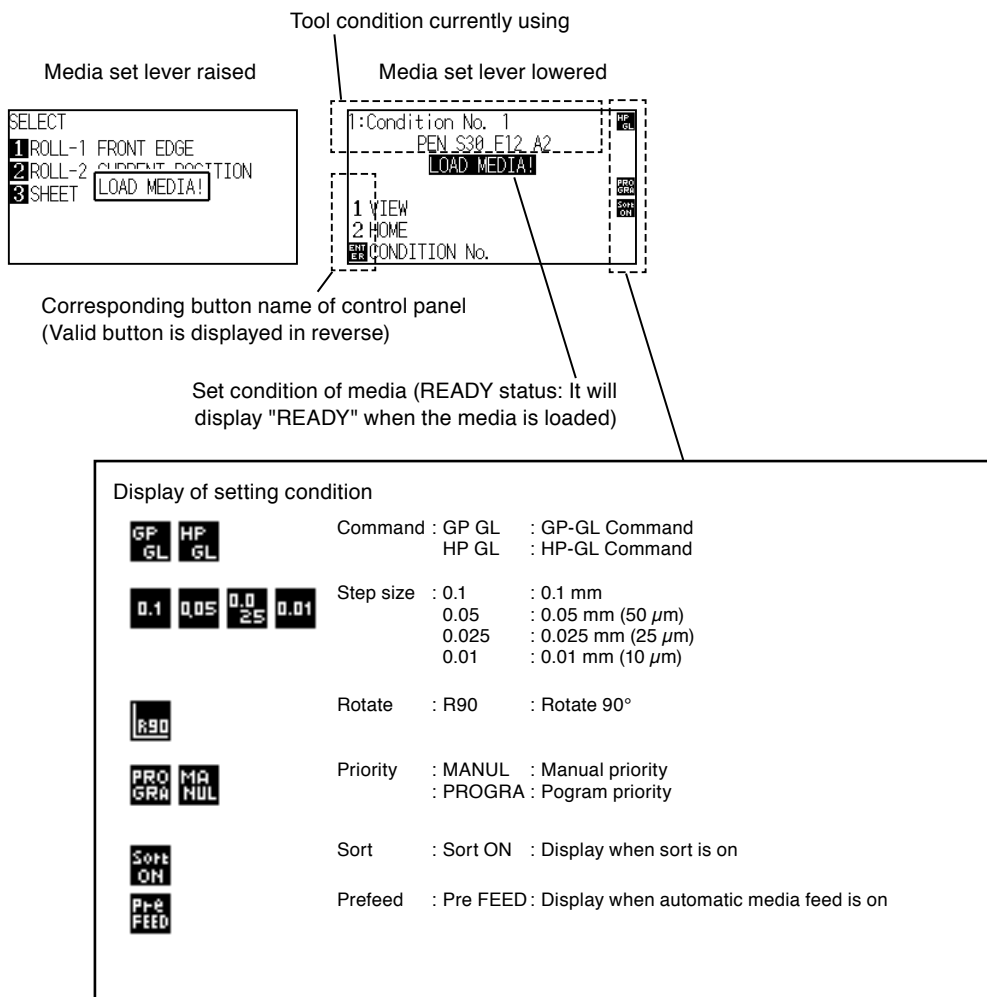

Default Screen (Ready Screen)

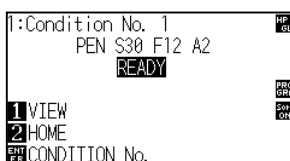

Screen to set the corresponding conditions is displayed when the [PAUSE/MENU] key or [COND/TEST] key are pressed.

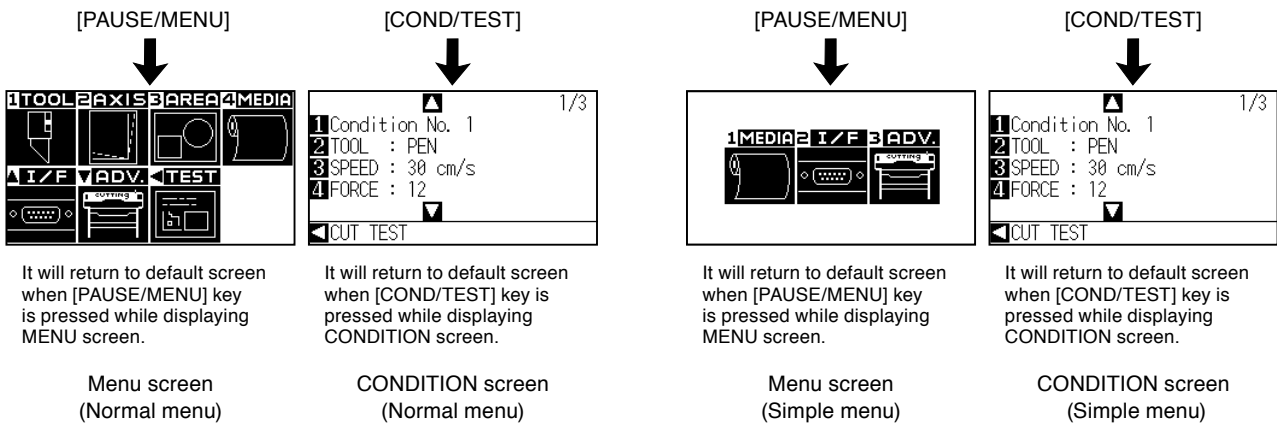

Page number is displayed in the upper right corner of the screen if there are too many settings or selection that will need multiple pages to display.

Press the POSITION (▲▼) key to move to different page.

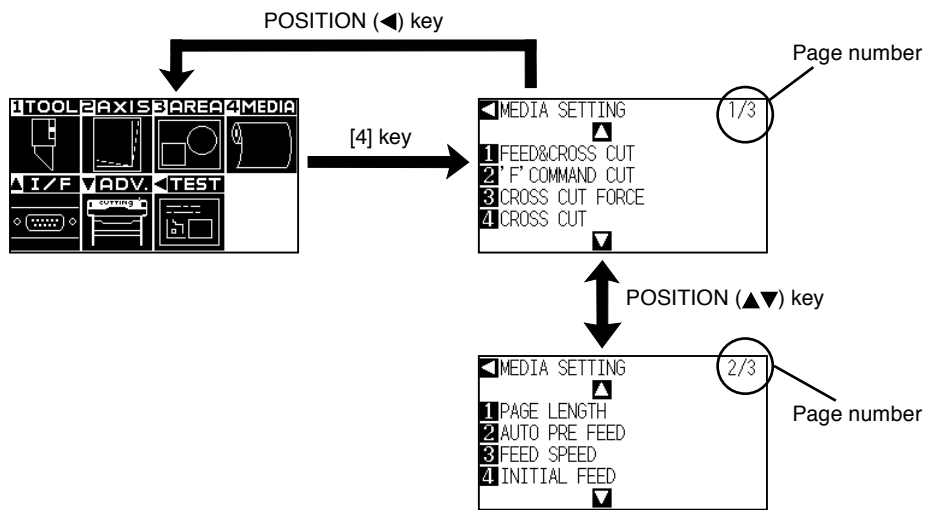

Example of moving page and operation button (Normal menu)

Icon of the corresponding operation button is displayed in the screen to change the setting values.



Increase or decrease the setting value using POSITION (▲▼) key. Select the change unit by [FAST] key.

Select the setting by number keys (1, 2, 3, 4) or POSITION (▲▼◀▶) keys.

Example of screen to change the settings value

Contents of Operation from Menu Screen

You can use the [SIMPLE] key on the default screen to switch between Simple menu and Normal menu.

In Simple menu you can change easy settings from the menu screen.

In Normal menu, you will be able to change more detailed settings.

Simple mode and Normal mode are independent from one another. The settings of the mode you're currently in will take precedence.

➡ P.2-43 See "About Simple menu" for more information.

Simple menu

In Simple menu, [1], [2], [3] keys can be used.

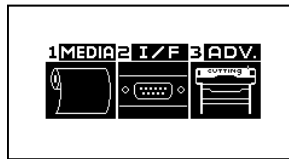

Menu screen (Simple menu)

Contents of the operation and settings that is displayed in MENU screen with [PAUSE/MENU] key is as following:

[1] (MEDIA) : Set the setting of the condition for the media.

[2] (I/F) : Set the settings of the condition for the interfacing with the control computer.

[3] (ADV) : Make the settings of the conditions for the basic operation of the CE6000-120AP such as unit of length.

[PAUSE/MENU] : It will close the MENU screen and return to default screen.

[FAST] : Displays the position key screen. When media is set, the tool point can be moved.

➡ P.A-5 See the "Menu Tree" for list of the descriptions about each settings.

Normal menu

In Normal mode, [1], [2], [3], [4] and [▲], [▼], [◀] keys can be used.



Menu screen (Normal menu)

Contents of the operation and settings that is displayed in MENU screen with [PAUSE/MENU] key is as following:

[1] (TOOL) : Set the setting for the operation of the tool.

[2] (AXIS) : Makes corrections on the axis bases on 2 points of comparison.

[3] (AREA) : Make the settings for area and rotation, etc., of the cutting.

[4] (MEDIA) : Set the setting of the condition for the media.

[▲] (I/F) : Set the settings of the condition for the interfacing with the control computer.

[▼] (ADV) : Set the settings of the conditions for the basic operation of the plotter, such as display language, unit of the measurements.

[◀] (TEST) : Does the operation necessary for maintenance, such as self diagnostic test or printout of the condition settings list.

[PAUSE/MENU] : It will close the MENU screen and return to default screen.

[FAST] : Displays the position key screen. When media is set, the tool point can be moved.

➡ P.A-5 See the "Menu Tree" for list of the descriptions about each settings.

Contents of Operation from [COND/TEST] Key

Simple menu is the same as normal menu.

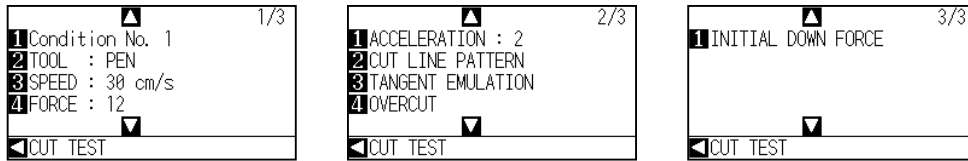

CONDITION screen (1-3) : (Normal mode)

Tool conditions are set in the setting screens displayed by the [COND/TEST] key.

Up to 8 CONDITION settings can be saved with different settings in numbers 1 through 8.

[COND/TEST]: This will clear the CONDITION screen and return to default screen.

➡ P.2-29 See "2.10 Selecting Tool Condition" for the detailed tool condition.

2.8

Setting Feeding Method

Feeding method for the loaded media is set.

Operation

- 1 If you have already loaded the media, the MEDIA TYPE menu appears. Select the media type to suit the loaded media.

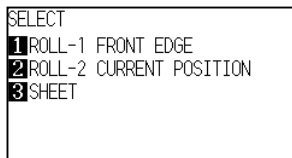

Check that the media stopper is unlocked and then select a media type on the media set setting screen.

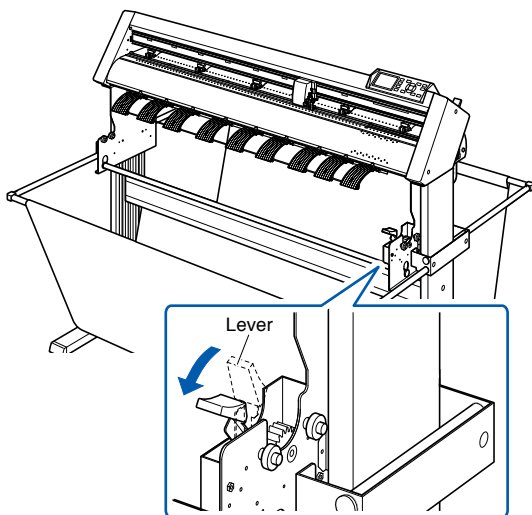

Lowering the lever releases the stopper lock.

When Selecting [ROLL-1 FRONT EDGE] Pressing the [1] Key

Select this when you have loaded a roll of media and you wish to start cutting or plotting from the leading edge. The width and leading edge of the roll media are detected.

When Selecting [ROLL-2 CURRENT POSITION] Pressing the [2] Key

Select this when you have loaded a roll of media and you wish to start cutting or plotting from a point beyond the leading edge.

Only the width of the roll media is detected.

When pressing the [3] key to select SHEET

Select this when a cut sheet has been loaded. The width, leading edge, and trailing edge of the sheet are detected.

CAUTION

Before doing the media set selection, make sure to release the media lock.

Supplement

The CONTINUE menu parameter appears when the media set lever is raised and then lowered again after media was previously loaded, making it possible to select the previous settings.

Pressing the [4] key to Continue (Do the same thing as last time)

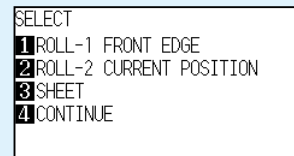

When using the same media without changing the position of the media, the CONTINUE function enables the continued use of the plotting area, pen position and origin position that were specified before the media set lever was lowered. If the current media is the same size as the last media that was loaded, the plotter does not detect the media's edges.

Supplement

When selecting [1] or [2] key

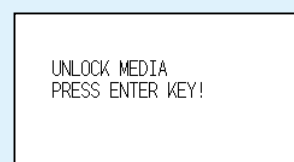

Please confirm on the confirmation screen that the lever lock has been released, then press the [ENTER] key. This will be displayed on the above screen.

When selecting [3] key

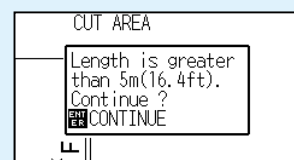

The above screen will display when set-up for media more than 5 meters long. Please confirm and then press the [ENTER] key To cancel, please lower the media set level and change the media.

- 2 When selecting [1] or [2] key, the following screen is displayed.

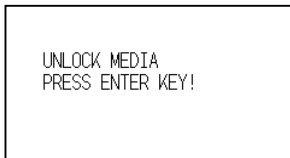

Please confirm that the stock shaft lock has been released, then press the [ENTER] key.

When [3] key is selected to set-up media more than 5 meters long, the following screen is displayed.

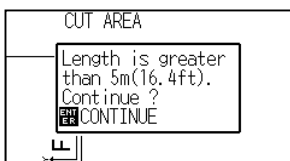

Please confirm, then press the [ENTER] key. To cancel, please lower the set level and change the media.

- 3 After the media is detected, the plotter is ready to receive data for cutting or plotting. This status is called "READY status" of the default screen.
- When setting is finished, the tool carriage's location will become the initial point.
- If the interface or command settings have not been made, make these settings before sending the data.
- If the settings have been made, tool adjustment is performed.
- When the pen adjustments have been made, the plotter is ready to start cutting.
- Send the cutting or plotting data from the application software.

▶ Default screen is displayed.

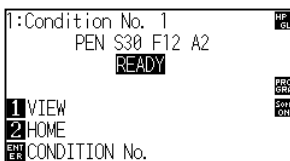

Supplement

The screen below shows a machine currently detecting media.

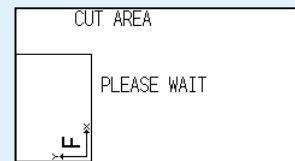

2.9

Auto media transfer and cross cut

The auto media transfer and cross cut action performs cross_cuts in single page sections.

1. The length of a single page is determined in "page length" under "settings".

When in operation, it performs a cross_cut from the current tool position.

➔ P.4-5 "Setting Length of the Page"

Operation

1 Press the [PAUSE/MENU] key in READY status.

▶ MENU screen is displayed.



MENU screen
(Normal menu)

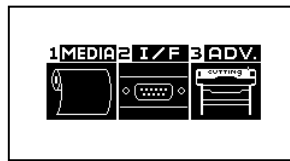

MENU screen
(Simple menu)

2 Press [4] key (MEDIA) in Normal menu, or [1] key (MEDIA) in Simple menu.

▶ MEDIA SETING screen is displayed.

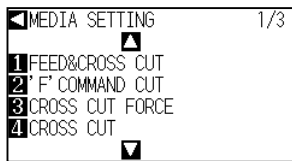

MEDIA SETING screen
(Normal menu)

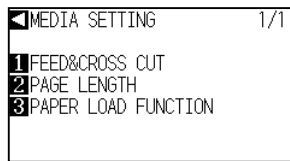

MEDIA SETING screen
(Simple menu)

3 Press the [1] key (FEED&CROSS CUT).

▶ Auto media transfer and cross cut screen is displayed.

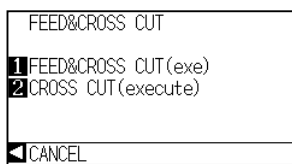

4 Press [1] key (FEED&CROSS CUT) or [2] key (CROSS CUT) to begin operation.

With "FEED&CROSS CUT," cross-cutting will begin after 1 page has been transferred.

"CROSS CUT" will start from the current tool position when you press [2] key.

5 Press the [PAUSE/MENU] key.

▶ It will return to default screen.

CAUTION

Pressing [1] or [2] key activates the tool carriage. Take care to ensure that you do not cut your fingers on the cutter blade.

2.10

Selecting Tool Condition

Tool condition can remember up to 8 settings.

Changing these settings allows you to make the proper settings for each different type of media.

Selecting Tool Condition

Condition No.1 applies specifically to use of the pen plunger for the either oil-based ballpoint pen or water based fiber-tip pen.

Condition No.2 to No.8 applies specifically to the use of the cutter plunger.

Operation

- 1 Press the [COND/TEST] key in the default screen.

▶ CONDITION setting screen (1/3) is displayed.

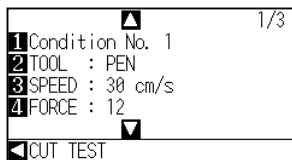

Supplement

CONDITION No. can also be changed from READY status. See "Changing CONDITION No." [P.3-6](#).

- 2 Press the [1] key (Condition No.).

▶ CONDITION No. selection screen is displayed.

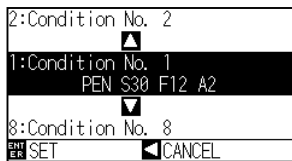

- 3 Press the POSITION (▲▼) key and select the setting (CONDITION No.).

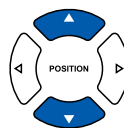

Supplement

It will return to CONDITION screen without changing the settings when you press the POSITION (◀) key (CANCEL).

- 4 Confirm the setting and press the [ENTER] key (SET).

▶ Setting will be set, and it will return to CONDITION screen (1/3)

- 5 Press the [COND/TEST] key.

▶ It will return to default screen.

Setting the Tool Condition

This section describes how to make the tool, speed, force, acceleration, and tool number settings. Before cutting media, the following four cutter-pen conditions must be specified.

- FORCE
- SPEED
- ACCELERATION
- OFFSET

CAUTION

It may result to damaging the cutter blade or the cutting mat if the blade is extended too much.

Tool Conditions (Cutter Blade) for Each Media Type

Refer to the Cutter Blade Manual.

Blade Part Nos., Displayed Blade Types, and CUTTER OFFSET Values

Refer to the Cutter Blade Manual.

Reference Pen Conditions for Plotting Pen

Pen type	Part no.	Force	Speed (cm/s)	Acceleration
Oil-based ballpoint pen	KB700 series	12 to 31	60 or under	2 or under
Water-based fiber-tip pen	KF700 series	10 to 12	20 or under	2 or under

To prolong the pen life, set the FORCE to the lowest setting, and set the SPEED after checking to confirm that there are no faint lines or other problems during plotting.

Supplement

- Acceleration will become coarser, but the cut time is decreased when the settings for the speed and acceleration is set higher. Especially with the large media, good cut quality might not be achieved by rumbling media. Decrease the values for the speed and acceleration settings in that case.
- Acceleration will become good, but the cut time will increase when the settings for the speed and acceleration is set smaller.

Setting the Tool

Set the type and offset value of the tool that is used in each of the tool condition numbers.

Condition No.1 applies specifically to use of the pen plunger for the either oil-based ballpoint pen or water based fiber-tip pen.

Condition No.2 to No.8 applies specifically to the use of the cutter plunger.

Setting Condition No.1 (Pen plunger specific)

Operation

- 1 Press the [COND/TEST] key in the default screen.

▶ CONDITION setting screen (1/3) is displayed.

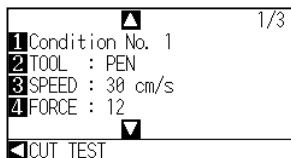

- 2 Press the [2] key (TOOL).

▶ TOOL setting screen is displayed.

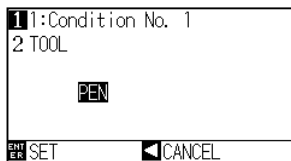

- 3 Press the [1] key.

▶ CONDITION No. selection screen is displayed.

* Display may vary depending on the selected condition number.

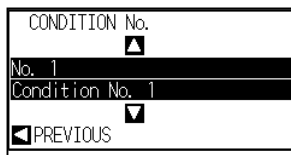

- 4 Press the POSITION (▲▼) keys to select the Condition No. of the Tool/Offset you wish to change.
From here, select "Condition No.1"

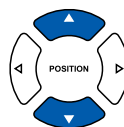

- 5 Confirm the setting and press the POSITION (◀) key (PREVIOUS).

▶ CONDITION No. will get set and return to TOOL setting screen.

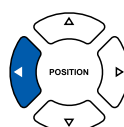
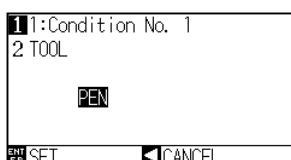

Supplement

Please select Condition No.1 under "Selecting the Tool Conditions" when setting up tool conditions for the pen plunger, and choose "Condition No.2" to "Condition No.8" when setting up the tool conditions for the cutter plunger. For more information, see "2.10 Selecting Tool Condition" [P.2-29](#).

Supplement

It will return to CONDITION screen without changing the settings when you press the POSITION (◀) key (CANCEL).

- 6 Confirm that "PEN" is set and press the POSITION (◀) key (PREVIOUS).

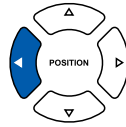

Supplement

Please note that Condition No.1 is pen plunger specific, and does not alter other tool settings.

- 7 Press the [COND/TEST] key.
▶ It will return to default screen.

Setting for Condition No.2 to No.8 (For cutter plunger)

Operation

- 1 Press the [COND/TEST] key in the default screen.
▶ CONDITION setting screen (1/3) is displayed.

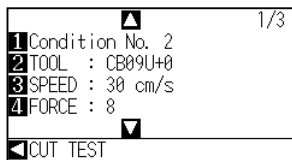

Supplement

Please select Condition No.1 under "Selecting the Tool Conditions" when setting up tool conditions for the pen plunger, and choose "Condition No.2" to "Condition No.8" when setting up the tool conditions for the cutter plunger. For more information, see "2.10 Selecting Tool Condition" [P.2-29](#).

- 2 Press the [2] key (TOOL).
▶ TOOL setting screen is displayed.

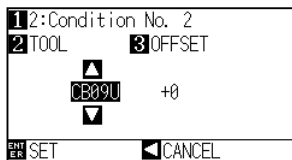

Supplement

It will return to CONDITION screen without changing the settings when you press the POSITION (◀) key (CANCEL).

- 3 Press the [1] key.
▶ CONDITION No. selection screen is displayed.
* Display may vary depending on the selected condition number.

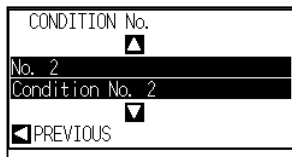

- 4 Press the POSITION (▲▼) keys to select the Condition No. of the TOOL/OFFSET you wish to change.
From here, select "Condition No.2"

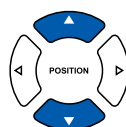

5 Confirm the setting and press the POSITION (◀) key (PREVIOUS) .

▶ CONDITION No. will get set and return to TOOL setting screen.

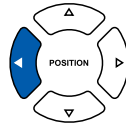

6 Press the POSITION (▲▼) key, and set the tool.

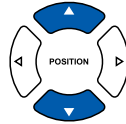
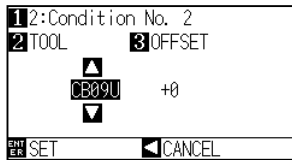

Supplement

- It will return to CONDITION screen without changing the settings when you press the POSITION (◀) key (CANCEL) .

7 Press the [3] key (OFFSET).

▶ OFFSET setting screen is displayed.

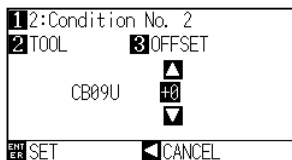

8 Press the POSITION (▲▼) key and increase or decrease the setting value.

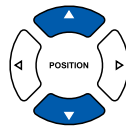

Supplement

- What is Offset
It will adjust the difference between the tip of the blade in the plunger and the center of the plunger. There are standard adjustment values for each cutter blades. Fine adjustment will be made to that standard values here. (Adjustment will be made with standard value as 0.)
It is not necessary to set the offset if "PEN", was selected in the tool settings. (not displayed)
- Guideline to Set Offset
Refer to the Cutter Blade Manual.
- To return to continue the settings of other tool condition number, return to step 3 by pressing the [1] key.

9 Confirm the setting and press the [ENTER] key (SET).

▶ Setting will be set, and it will return to CONDITION screen (1/3).

10 Press the [COND/TEST] key.

▶ It will return to default screen.

Setting the Speed

Set the speed of the tool that is used in each of the condition numbers.

Setting range: 1 to10 (in 1 cm/s increment), 10 to 60 (in 5 cm/s increment)

Operation

- 1 Press the [COND/TEST] key in the default screen.

▶ CONDITION setting screen (1/3) is displayed.

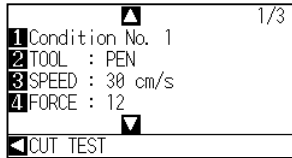

- 2 Press the [3] key (SPEED) .

▶ SPEED setting screen is displayed.

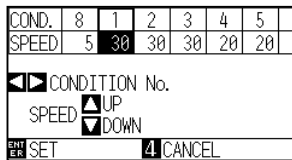

* Display may vary depending on the selected tool condition number.

- 3 Press the POSITION (◀▶) key and select the tool condition number (CONDITION No.) .

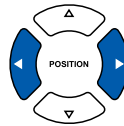

- 4 Press the POSITION (▲▼) key and increase or decrease the setting value.

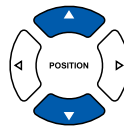

- 5 Confirm the setting and press the [ENTER] key (SET).

▶ Setting will be set, and it will return to CONDITION screen (1/3).

- 6 Press the [COND/TEST] key.

▶ It will return to default screen.

Supplement

Please select Condition No.1 under "Selecting the Tool Conditions" when setting up tool conditions for the pen plunger, and select from Condition No.2 to Condition No.8 when setting up the tool conditions for the cutter plunger. For more information, see "2.10 Selecting Tool Condition" [▶ P.2-29](#) .

Supplement

It will return to CONDITION screen (1/3) without changing the settings when you press the [4] key (CANCEL) .

Supplement

Guideline to set speed
See "Setting the Tool Condition" [▶ P.2-30](#) .

Setting the Force

Set the cutting force that is used in each of the condition numbers.

Setting range: Condition No.1: 1 to 31

Condition No.2 to No.8: 1 to 38

Operation

- 1 Press the [COND/TEST] key in the default screen.

▶ CONDITION setting screen (1/3) is displayed.

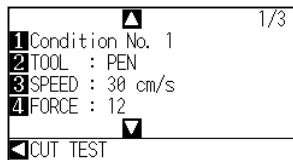

- 2 Press the [4] key (FORCE).

▶ FORCE setting screen is displayed.

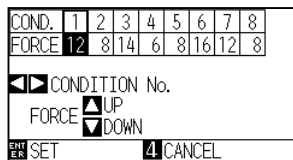

* Display may vary depending on the selected condition number.

- 3 Press the POSITION (◀▶) key and select the condition number (CONDITION No.).

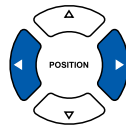

- 4 Press the POSITION (▲▼) key and increase or decrease the setting value.

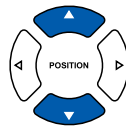

- 5 Confirm the setting and press the [ENTER] key (SET).

▶ Setting will be set, and it will return to CONDITION screen (1/3).

- 6 Press the [COND/TEST] key.

▶ It will return to default screen.

Supplement

Please select Condition No.1 under "Selecting the Tool Conditions" when setting up tool conditions for the pen plunger, and select from Condition No.2 to Condition No.8 when setting up the tool conditions for the cutter plunger. For more information, see "2.10 Selecting Tool Condition" [▶ P.2-29](#).

Supplement

It will return to CONDITION screen (1/3) without changing the settings when you press the [4] key (CANCEL).

Supplement

Guideline to set force
See "Setting the Tool Condition" [▶ P.2-30](#).

Setting the Acceleration

Set the acceleration of the tool that is used in each of the tool condition numbers.

Setting range: 1 to 2

Operation

- 1 Press the [COND/TEST] key in the default screen.

▶ CONDITION setting screen (1/3) is displayed.

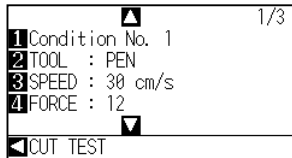

Supplement

Please select Condition No.1 under "Selecting the Tool Conditions" when setting up tool conditions for the pen plunger, and select from Condition No.2 to Condition No.8 when setting up the tool conditions for the cutter plunger. For more information, see "2.10 Selecting Tool Condition" [▶ P.2-29](#).

- 2 Press the POSITION (▲) key.

▶ CONDITION setting screen (2/3) is displayed.

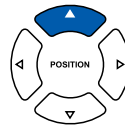
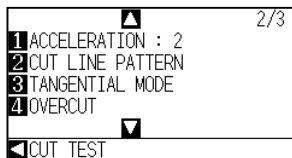

- 3 Press the [1] key (ACCELERATION).

▶ ACCEL setting screen is displayed.

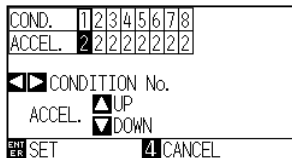

* Display may vary depending on the selected tool condition number.

Supplement

It will return to CONDITION screen (2/3) without changing the settings when you press the [4] key (CANCEL) .

- 4 Press the POSITION (◀▶) key and select the tool condition number (CONDITION No.).

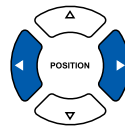

- 5 Press the POSITION (▲▼) key and increase or decrease the setting value.

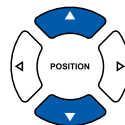

Supplement

Guideline to set acceleration
See "Setting the Tool Condition" [▶ P.2-30](#).

- 6 Confirm the setting and press the [ENTER] key (SET).

▶ Setting will be set, and it will return to CONDITION screen (2/3).

- 7 Press the [COND/TEST] key.

▶ It will return to default screen.

Adjust the Blade Length

Optimal cut is not achieved unless the blade length is adjusted in accordance to the used media and the cutter blade. Perform further adjustment by performing cutting test after adjusting the blade length manually.

CAUTION

- To avoid bodily injury, handle cutter blades with care.
- It may result to damaging the cutter blade or the cutting mat if the blade is extended too much.

Supplement

See "Running Cutting Tests" [P.2-41](#) or cutting tests.

Operation

- 1 Align the blade tip to the tip of the cutter pen, and make it touch the surface of the media.

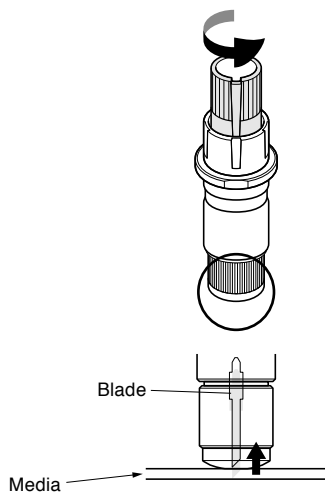

- 2 The blade will gradually extend to suit the thickness of the media being cut; the optimal length is slightly greater than the thickness of the media. A test cut will then be performed, and the blade length adjusted if there is any media left uncut.

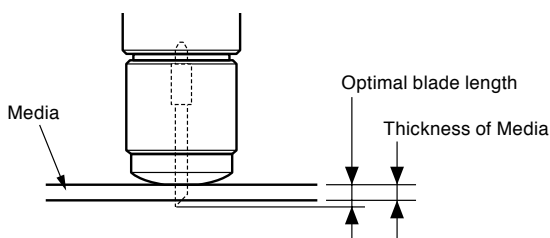

Supplement

- Blade length can be changed by spinning the adjuster on the blade. Spinning it in the A direction pushes it out, while spinning it in the B direction pulls it in. One scale unit is equal to 0.1 mm.

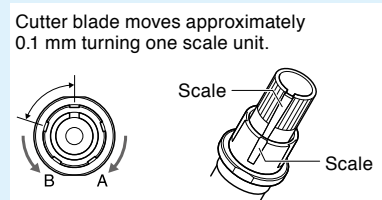

- Guideline to Set the Blade Length
See "Setting the Tool" [P.2-30](#) for the thickness of the media.

2.11

Setting Cut Line Pattern

Lines can be cut with perforated lines so the cut parts will not fall off. There are 8 different perforation patterns of perforated lines set as 0 to 7, and the ratio of cut and uncut part differs in each. (Cut length decreases cutting perforation length, up length decreases the perforation connection length or the connection cut force.)

The cut part becomes longer with a larger value, and becomes easier to separate the cut parts with a smaller up value.

In addition to above 8 patterns, there are "OFF", which cuts by the solid line without perforation patter, "NONE", which controls the perforation patter with the command, and "USER", where user can specify a unique pattern. The processing in the part is not cut with perforation patter is adjusted in "UP MODE".

The perforation patter can be set for each condition number.

Supplement

- Use the holder (forward).

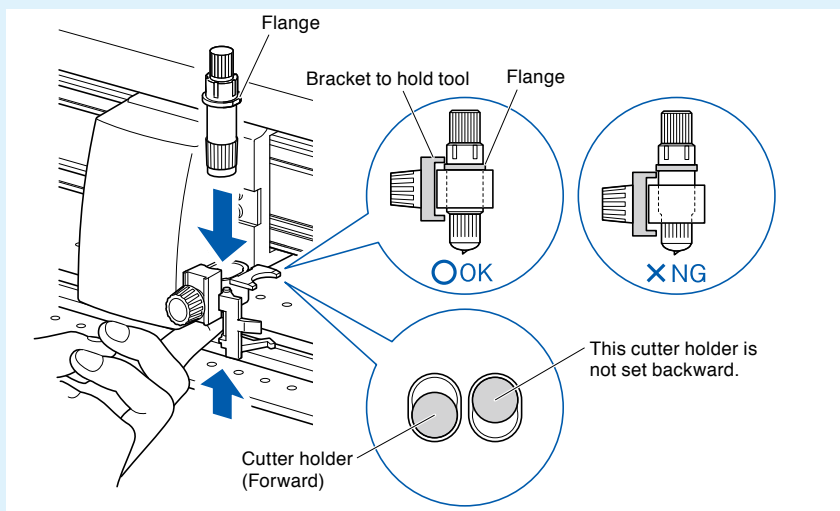

- Damaged marking mats can be replaced at the owner's expense.
- When controlling the perforated pattern with FORCE setting command, set to "NONE".

Guideline to perforation pattern

Thickness of material	Pattern number	Cutting length (L)	Up length (L)
Approx. 130 g/m ²	3	30.00 mm	1.00 mm
Approx. 80 g/m ²	5	30.00 mm	1.40 mm
Approx. 65 g/m ²	1	15.00 mm	1.40 mm

* The materials of 60g/m² or less are not suitable for cut with perforation pattern. We recommended that they are used for a pen plotting.

Operation

- 1 Press the [COND/TEST] key.
 - ▶ CONDITION setting screen (1/3) is displayed.

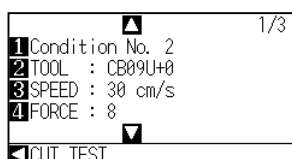

Supplement

Condition No.1 is pen specific. When setting up tool conditions for the cutter plunger, please choose from Condition No.2 to Condition No.8 under "Selecting the Tool Condition". For more information, see "2.10 Selecting Tool Condition" [P.2-29](#).

2 Press the POSITION (▲) key.

▶ CONDITION screen (2/3) is displayed.

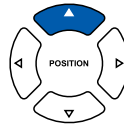
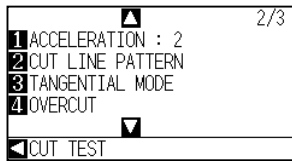

Supplement

It will return to default screen without changing the settings when you press the [CONDITION] key.

3 Press the [2] key (CUT LINE PATTERN).

▶ CUT LINE PATTERN setting screen is displayed.

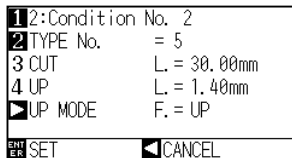

4 Press the [1] key (Condition No.).

▶ CONDITION No. selection screen is displayed.

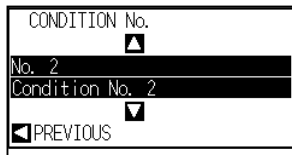

5 Press the POSITION (▲▼) key and select the CONDITION No.

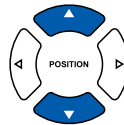

6 Confirm the setting value, and press the POSITION (◀) key (PREVIOUS).

▶ CONDITION No. is selected and return to CUT LINE PATTERN setting screen.

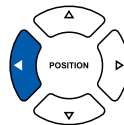

7 Press the [2] key (TYPE No.).

▶ TYPE No. setting screen is displayed.

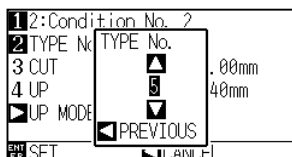

8 Press the POSITION (▲▼) key and select the TYPE No.

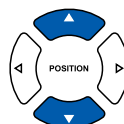

9 Confirm the setting value, and press the POSITION (◀) key (PREVIOUS).

▶ TYPE No. is selected and return to CUT LINE PATTERN setting screen.

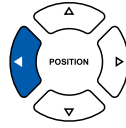
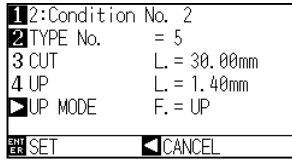

Supplement

- CUT L and UP L is displayed when the TYPE No. 0-7 is selected. Also, you will be able to set the UP MODE.
- Setting for all becomes enabled when USER is selected.
- Nothing will be displayed when "NONE" or "OFF" is selected.

10 Press the POSITION (▶) key (UP MODE).

▶ UP MODE setting screen is displayed.

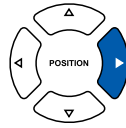
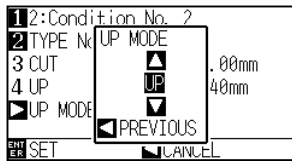

Supplement

Setting range is from 1 to 31, and "UP".

11 Press the POSITION (▲▼) key and set the UP MODE.

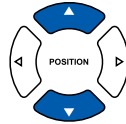

Supplement

Value set here will be the cut force for the uncut part of the perforated lines. Toll will be raised when set to "UP".

12 Confirm the setting, and press the POSITION (◀) key (PREVIOUS).

▶ It will return to UP MODE CUT LINE PATTERN setting screen.

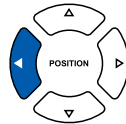

13 If the "USER" is chosen in step 8, press the [3] key (CUT) and the [4] key (UP) to set the cut length and tool up length. Follow steps 10 to 12 for this operation.

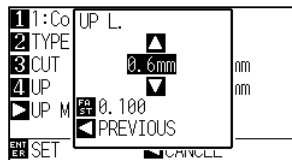
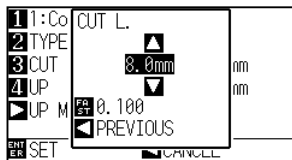

Supplement

- If the TYPE No. 0 to 7 is selected in step 8, CUT L and UP L is only displayed, and not possible to change. Skip this step, and proceed.
- Range possible to set for the CUT L is 0.1 mm to 100.0 mm.
- Range possible to set for the UP L is 0.1 mm to 10.0 mm.
- Digits of settings can be changed by pressing the [FAST] key.

14 Confirm the setting and press the [ENTER] key (SET) in the CUT LINE PATTERN setting screen.

▶ Setting will be set, and it will return to CONDITION screen (2/3).

15 Press the [COND/TEST] key.

▶ It will return to the default screen.

Supplement

It will return to CONDITION screen (2/3) without changing the settings when you press the POSITION (◀) key (CANCEL).

2.12 Running Cutting Tests

Test cutting can be performed after making the tool, speed, force, acceleration, and perforation pattern settings to ensure that the selected cutting conditions actually produce the desired cutting results. Check how far the blade cuts into the media and how the corners are being cut. If the cutting results are not satisfactory, adjust the various settings and repeat the test cutting until the optimal settings are achieved.

Cutting Test

Here, you can either cut one test pattern based on the current values.

Operation

- 1 Load the media for test cutting in the plotter.
- 2 Press the [COND/TEST] key in the default screen.

▶ In Normal mode, CONDITION screen (1/3) is displayed.

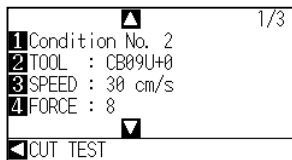

Supplement

Please choose from Condition No.2 to Condition No.8 under "Selecting the Tool Condition". For more information, see "2.10 Selecting Tool Condition" → P.2-29.

- 3 Press the POSITION (◀) key (CUT TEST).

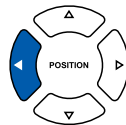
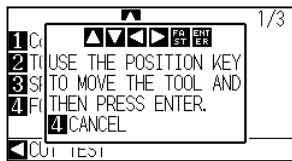

Supplement

It will return to CONDITION screen by pressing the [4] key (CANCEL).

- 4 Press the POSITION (▲▼◀▶) key the tool carriage to the location you wish to perform the test cutting.

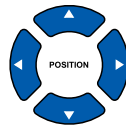

Supplement

Pushing the [POSITION] and [FAST] keys simultaneously will move the tool carriage faster.

- 5 Press the [ENTER] key.

▶ 1 cut test pattern is cut.

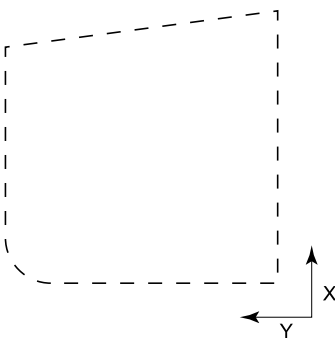

CAUTION

When the [ENTER] key is pressed, the tool carriage will start moving, so take care not to cut your fingers.

- 6 Press the [ENTER] key after completion.

▶ CONDITION screen is displayed.

- 7 Press the [COND/TEST] key.

▶ It will return to default screen.

Confirm the Results of the Cutting Test

Confirm the cutting test results, and adjust to optimal setting. Repeat cutting test and adjustment until optimal cut is achieved.

Adjustment of Offset

Check the corners of the triangles and rectangles. See "Setting the Tool Condition" [P.2-30](#) and adjust the offset value if the corner is not cut or if it is cut too much.

Supplement

How to check offset:

Check if the offset value is set correctly by following.

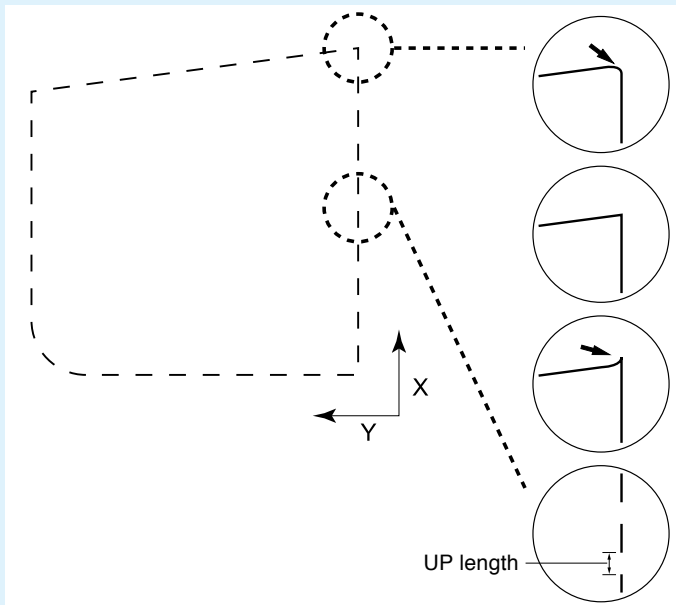

Not enough adjustment.
Increase the offset value.

Optimal offset value.

Too much adjustment.
Decrease the offset value.

Check the UP length when cutting.
When the UP length is not enough, those that
are cut during cutting, may come off.

Adjustment for Cutting Out

Adjust so the media is completely cut out.

If the media is not completely cut, either the FORCE setting is too low or the cutter blade tip is not sufficiently extended.

See "Adjusting the Blade Length" [P.2-2](#) and "Setting the Force" [P.2-35](#) and adjust the settings.

Adjustment When Using Plotting Pen

Adjust the FORCE so there will be no faint lines. To prolong the pen life, set the FORCE to the lowest setting without any faint lines. See "Setting the Force" [P.2-35](#) or setting the FORCE.

2.13

About Simple menu

Simple settings can be made from the menu in Simple menu.

The green Simple Lamp will come on when Simple mode is activated.

In the default screen, the [SIMPLE] key allows you to change between Simple menu and Normal menu.

Supplement

In Simple menu, TOOL, AXIS, AREA, TEST settings are not available..

You can choose the following settings on Simple mode's default screen.

➡ P.2-21 See "How to Use Control Panel" for detailed information.

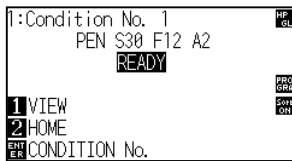

[COND/TEST] : Set "Tool Conditions". (See ➡ P.2-29 : Selecting Tool Condition)

[COPY] : Make a copy. (See ➡ P.4-11 : Copy)

You can choose the following settings on the Simple mode menu screen.

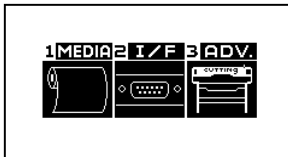

MENU screen
(Simple menu)

[1] (MEDIA) : Set "FEED & CROSS CUT", "PAGE LENGTH", and "PAPER LOAD FUNCTION".

[2] (I/F) : Set "SELECT USER", and "RS-232C".

[3] (ADV) : Set "LENGTH UNIT".

That concludes the Simple mode menu screen setting explanation.

2.13.1 Setting Page Length (Simple mode)

Use 1 Page Length when using Roll media.

If the machine receives data for a cut longer than the set page length, it will only cut for the set area parameters. The excess area will not be cut.

This can also be set in Normal mode.

Reference

- Default page length is 3 m. When doing long cuts, set the page length. Check the setting of the page length when cutting long length.
 - * Be sure to use the basket.
- For the CE6000-120AP, the page length up to 50 m can be set. We give quality assurance for page feeding up to 3 m. (Under the condition that the media described below is used.)
 - Be sure to use the basket.
 - Media: genuine Graphtec brand products
 - Setting Conditions: Speed under 30, acceleration under 2.
 - Perform pre feed for the amount to be used before cutting.
 - Leave the media in environment to use for adequate time if the deviation of temperature and humidity is big.
 - Set the both push rollers at least 15mm inside the edge of media.
 - The paper needs to be reset after cutting 5 consecutive pages.
 - Each page should be removed from the basket after it has been cut.
- When setting media for long-plotting, set the tension on the left and right of the width of the media to a uniform value. If it is not uniform, the media may be removed from the roller that presses it during plotting.
- Make sure to level the whole of the media to get rid of unevenness before cutting. (See "Setting the number of pre feeds" [▶P.4-7](#)). Also, pre feeding can be done automatically when the data is received (see "Perform Automatic Pre Feed When Cut Data is Received" [▶P.7-4](#)), or done automatically when the media is loaded (see "Perform Automatic Pre Feed When Media is Set (Initial Feed)" [▶P.7-6](#)).
 - * Pre feeding will stabilize the feed by acclimating the media, taking out the slack.
- This setting is maintained even after the power is turned off.

Operation

1 Press [PAUSE/MENU] key.

▶ MENU screen is displayed.

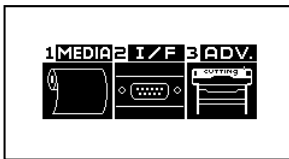

2 Press [1] key (MEDIA).

▶ MEDIA SETTING screen is displayed.

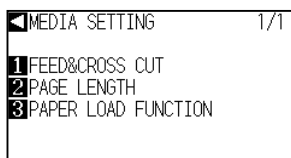

3 Press [2] key (PAGE LENGTH).

▶ PAGE LENGTH screen is displayed.

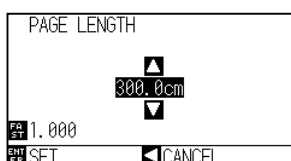

- 4 Press the POSITION (▲▼) keys to change the current setting.

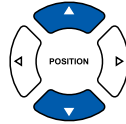

- 5 Confirm the setting and press the [ENTER] key (SET).

▶ Setting will be set, and it will return to MEDIA SETTING screen.

- 6 Press [PAUSE/MENU] key.

▶ It will return to default screen.

Supplement

- Press the [FAST] key to change the setting digits.
- You can enter any digit between 20.0cm and 5000.0cm.
- The following screen will display if using a setting greater than 500cm.

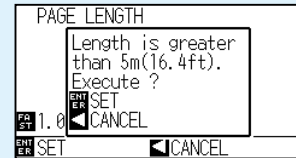

After confirming, press the [ENTER] key.

Supplement

Press the POSITION (◀) key to return to the MEDIA setting screen without changing any settings.

2.13.2 Setting the number of pre feeds (Simple menu)

Set the number of pre feeds to prevent deviations from occurring when the roll media is pulled out. During the pre feed, the grit roller leaves traces on the paper. Pre feeds can be repeated after paper exposure time has elapsed (see "Setting paper Ready time" [➔ P.4-8](#)). This function is available when the Initial Feed or if Partition Pastern are activated, and can be set under the "normal" menu.

This setting is enabled only when the initial feed setting is "On", or the partition pastern is "On".

You can also be set it on the Normal menu.

Operation

1 Press [PAUSE/MENU] key.

▶ MENU screen is displayed.

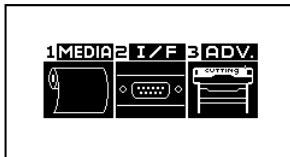

2 Press [1] key (MEDIA).

▶ MEDIA SETTING screen is displayed.

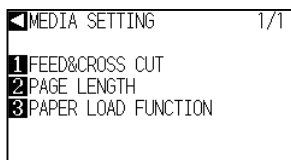

3 Press [3] key (PAPER LOAD FUNCTION).

▶ PAPER LOAD FUNCTION setting screen is displayed.

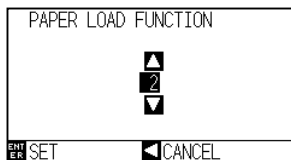

4 Press the POSITION (▲▼) keys to change the current setting.

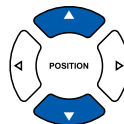

5 Confirm the setting and press the [ENTER] key (SET).

▶ Setting will be set, and it will return to MEDIA SETTING screen.

6 Press [PAUSE/MENU] key.

▶ It will return to default screen.

Supplement

- You can set between 0 and 5.
- Cutting/plotting will begin immediately after the pre feed is complete and data sent during paper exposure time is received.

Supplement

Press the POSITION (◀) (CANCEL) key to return to the MEDIA SETTING screen without changing any settings.

2.13.3 User selection settings (Simple menu)

Call up the user selection settings (CAD). "Command", "Origin point", "Step size", "Separator", "Timeout", "Page length", and "Transfer conditions for RS-232C" have been set.

You can also be set in Normal menu.

List of user selection settings

User selection settings	1	2	3	4	5	6	7	8
Command	HP-GL	HP-GL	GP-GL	HP-GL	HP-GL	HP-GL	HP-GL	HP-GL
Step size	0.025	0.025	0.025	0.025	0.025	0.025	0.025	0.025
Origin point	LOWER LEFT	CENTER	LOWER LEFT	LOWER LEFT	LOWER LEFT	CENTER	CENTER	CENTER
Separator	PG	NR	J0	SP	PG	SP	None	None
Time out	0	0	120	120	1	10	0	0
Page length (mm)	1500	3000	1500	5000	3000	1500	5000	5000
Transfer conditions	9600N81X	9600N81X	9600N81X	9600N81X	9600N81X	19200N81X	9600N81X	9600N81X
Step pass	–	–	–	–	–	0	–	–
Tool up speed	–	–	–	–	–	60 cm/s	–	–
Cross cut	–	–	–	–	–	ON	–	–
Cut line pattern	–	–	–	–	–	OFF	–	–
Space rear	–	–	–	–	–	12 mm	–	–

–: The current value is set.

User preference 6 is determined as per the following cutter pen conditions (all settings other than those listed revert to default).

The settings other than the table are set to default value.

Condition No.	Speed	Acceleration	Force	Pen type (Cutter blade)	Compensation value (Offset)
1	60	1	17	Pen	–
2	30	1	14	09U	0
3	30	1	14	09U	0
4	30	1	14	09U	0
5	30	1	14	09U	0
6	30	1	14	09U	0
7	30	1	14	09U	0
8	60	1	14	09U	0

Operation

1 Press [PAUSE/MENU] key.

▶ MENU screen is displayed.

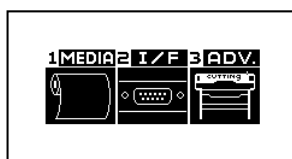

2 Press [2] key (I/F).

▶ INTERFACE screen is displayed.

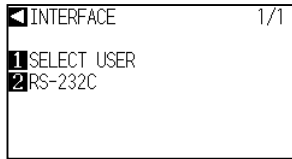

3 Press [1] key (SELECT USER).

▶ SELECT USER setting screen is displayed.

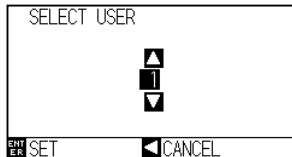

4 Press the POSITION (▲▼) keys to select the setting number.

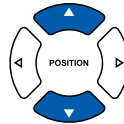

Supplement

There are 8 different setting numbers.

5 Confirm the settings and press the [ENTER] key (SET).

▶ Setting will be set, and the restart is activated.

Supplement

Press the POSITION (◀) key (CANCEL) to return to the INTERFACE setting screen without changing any settings.

2.13.4 Setting RS-232C interface (Simple menu)

When using the RS-232C interface, set the command settings, step size settings (when using GP-GL commands), origin point settings for HP-GL (when using HP-GL commands), and transfer conditions for the RS-232C interface.

In Normal menu, set the command settings, step size settings (when using GP-GL commands), origin point settings for HP-GL (when using HP-GL commands). (➡ P.10-2 "Setting the Command", ➡ P.10-4 "Setting the Step Size", ➡ P.3-9 "Setting Origin Point When HP-GL is Set")

The transfer condition for RS-232C interface can be set from the control panel. The transfer condition should be set to the same in the software used and in the CE6000-120AP. If there is a mistake in the settings an error may display in the machine and lack of data can cause a malfunction. In such a case, please confirm the transfer condition settings again.

Changing and saving the RS-232C interface settings

Operation

- 1 In default screen, press [PAUSE/MENU] key.

▶ MENU screen is displayed.

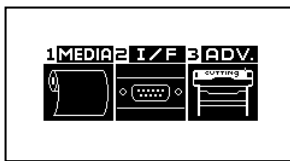

- 2 Press [2] key (I/F).

▶ INTERFACE screen is displayed.

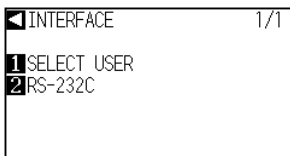

- 3 Press [2] key (RS-232C).

▶ RS-232C screen is displayed.



- 4 Press [1] key (BAUD RATE).

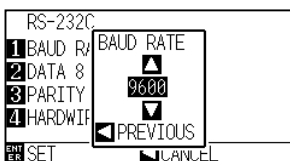

Supplement

Press the POSITION (◀) key (CANCEL) to return to the INTERFACE setting screen without changing any settings.

Supplement

Baud rate can be set to 19200, 9600, 4800, 2400, 1200, 600, or 300.

- 5 Press the POSITION (▲▼) keys and increase or decrease the setting value.

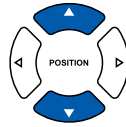

Supplement

Match it to the software you are using.

- 6 Confirm the settings and press the POSITION (◀) key (PREVIOUS).

▶ The baud rate is selected and it will return to RS-232C setting screen.

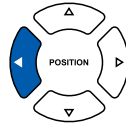

- 7 Press [2] key (DATA BIT).

▶ DATA BIT setting screen is displayed.

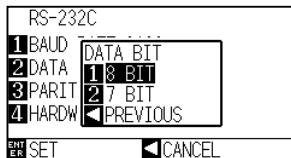

- 8 Press [1] key (8 BIT) or [2] key (7 BIT).

▶ Data length is set, and it will return to RS-232C setting screen.

Supplement

- Match it to the software you are using.
- Press the POSITION (◀) key (PREVIOUS) to return to the RS-232C setting screen without changing any settings.

- 9 Press [3] key (PARITY).

▶ PARITY setting screen is displayed.



- 10 Press [1] key (NONE), [2] key (EVEN), or [3] key (ODD).

▶ The parity is selected and it will return to RS-232C setting screen.

Supplement

- Match it to the software you are using.
- Press the POSITION (◀) key (PREVIOUS) to return to the RS-232C setting screen without changing any settings.

- 11 Press [4] key (HANDSHAKE).

▶ HANDWIRE setting screen is displayed.



12 Press [1] key (HARDWIRE), [2] key (X on/off), or [3] key (Enq/Ack).

▶ The handshake is selected and it will return to RS-232C setting screen.

13 Confirm the settings and press the [ENTER] key (SET).

▶ Setting will be set, and it will return to MEDIA setting screen.

14 Press [PAUSE/MENU] key.

▶ It will return to default screen.

Supplement

- Match it to the software you are using.
- Press the POSITION (◀) key (PREVIOUS) to return to the RS-232C setting screen without changing any settings.
- The Enq/Ack settings are available for HP-GL. Even if Enq/Ack is set for GP-GL, it is set to HARDWIRE.

2.13.5 Display Length Unit Settings (Length Unit) (Simple menu)

You can choose to have length units displayed in either meters or inches.
This can be changed in Normal mode.

Operation

- 1 In default screen, press [PAUSE/MENU] key.

▶ MENU screen is displayed.

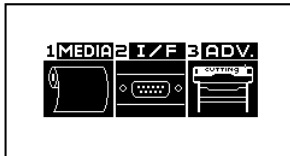

- 2 Press [3] key (ADV.).

▶ ADVANCE setting screen is displayed.

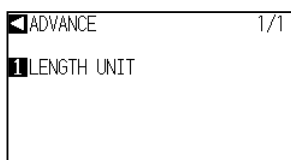

- 3 Press [1] key (LENGTH UNIT).

▶ LENGTH UNIT setting screen is displayed.

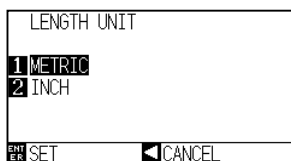

- 4 Press [1] key (METRIC) or [2] key (INCH).

- 5 Confirm the setting and press the [ENTER] key (SET).

▶ Setting will be set, and it will return to ADVANCE setting screen.

- 6 Press [PAUSE/MENU] key.

▶ It will return to default screen.

Chapter 3: Basic Operations

This chapter describes the basic methods to operate the plotter manually.

All the operations described in this chapter is to start from the READY status (media is set) as a general condition. Perform the operation described in this chapter after making the plotter in READY status referring to previous chapter.

PRODUCT SUMMARY

- 3.1 Raise or Lower the Tool***
- 3.2 Move the Tool Carriage and Media***
- 3.3 Setting the Origin Point***
- 3.4 Setting the Cutting Direction***
- 3.5 Stop Cutting***

3.1

Raise or Lower the Tool

This is a function to raise or lower the tool (pen).

Operation

- 1 Press the [PAUSE/MENU] key.

▶ MENU screen is displayed.



- 2 Press the [1] key (TOOL).

▶ TOOL SETTING (1/3) screen is displayed.

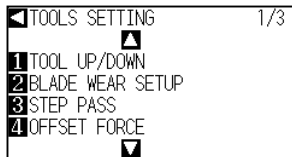

- 3 Tool is raised or lowered every time the [1] key (TOOL UP/DOWN) is pressed.

- 4 Press the [PAUSE/MENU] key.

▶ It will return to default screen.

Supplement

Perform the settings in Normal menu.

3.2

Move the Tool Carriage and Media

Tool carriage and media can be moved manually using the POSITION key.

It also can move the tool carriage and media to the origin, or move it certain distance to keep it away.

Move in Steps Manually

It can manually move in steps when the screen is displaying "READY", or when the POSITION (▲▼◀▶) key is displayed.

Operation

- 1 Press the POSITION (▲▼◀▶) keys once to move in the desired direction.

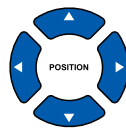

- ▶ Tool carriage or the media will move toward the direction of the pressed POSITION key for 1 step.

Supplement

- It will move in steps every time POSITION (▲▼◀▶) key is pressed.
- Distance of step movement can be changed. See "Setting of Step Movement Distance" [▶ P.3-4](#).

Continuously Move Manually

It can manually move continuously when the screen is displaying "READY", or when the POSITION (▲▼◀▶) key is displayed.

Operation

- 1 Hold the POSITION (▲▼◀▶) keys down to keep moving in the desired direction.

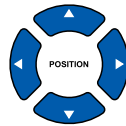

- ▶ Tool carriage or the media will keep on moving toward the direction of the pressed POSITION key.

- 2 Release the POSITION (▲▼◀▶) key.

- ▶ Movement of the tool carriage or the media will stop.

Supplement

Tool carriage will move faster when [FAST] key is pressed simultaneously with POSITION key.

Setting of Step Movement Distance

The parameters when setting the cutting direction are determined by the distance of the cutting direction.

Operation

- 1 Press the [PAUSE/MENU] key.

▶ MENU screen is displayed.



Supplement

Perform the settings in Normal menu.

- 2 Press the POSITION (▼) key (ADV).

▶ ADV. setting screen (1/2) is displayed.

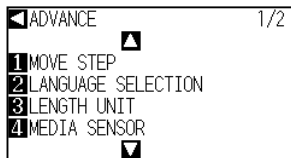

- 3 Press the [1] key (MOVE STEP).

▶ MOVE STEP screen is displayed.

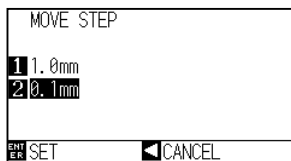

- 4 Press the [1] key (1.0mm) or the [2] key (0.1mm).

Supplement

Value chosen here will be the movement distance for the step movement.

- 5 Confirm the setting and press the [ENTER] key (SET).

▶ Setting will be set, and it will return to DEFAULT setting screen (1/2).

Supplement

It will return to DEFAULT setting screen (1/2) without changing the settings when you press the POSITION (◀) key (CANCEL).

- 6 Press the [PAUSE/MENU] key.

▶ It will return to default screen.

Move Away the Tool Carriage

It is possible to move the tool carriage toward upper right. It makes it easier to confirm the cutting results if you perform this operation after the cutting is completed.

<When using Roll Media>: Seen from above

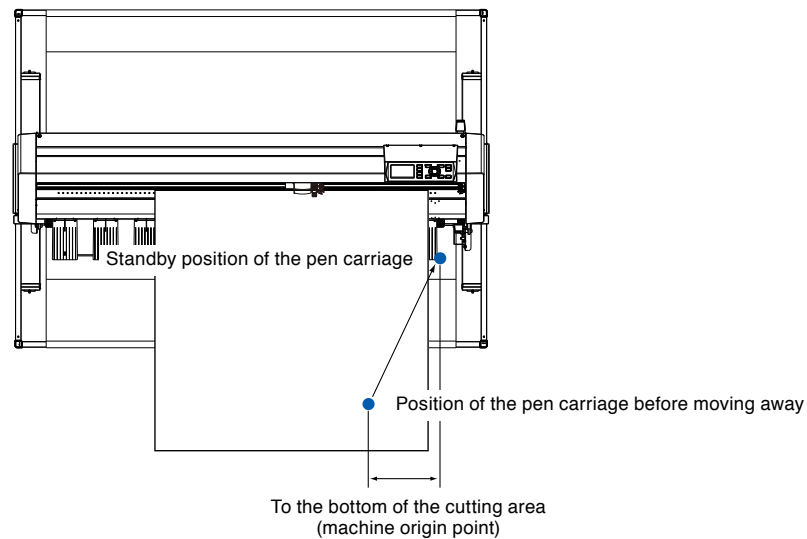

<When using Sheet Media>: Seen from above

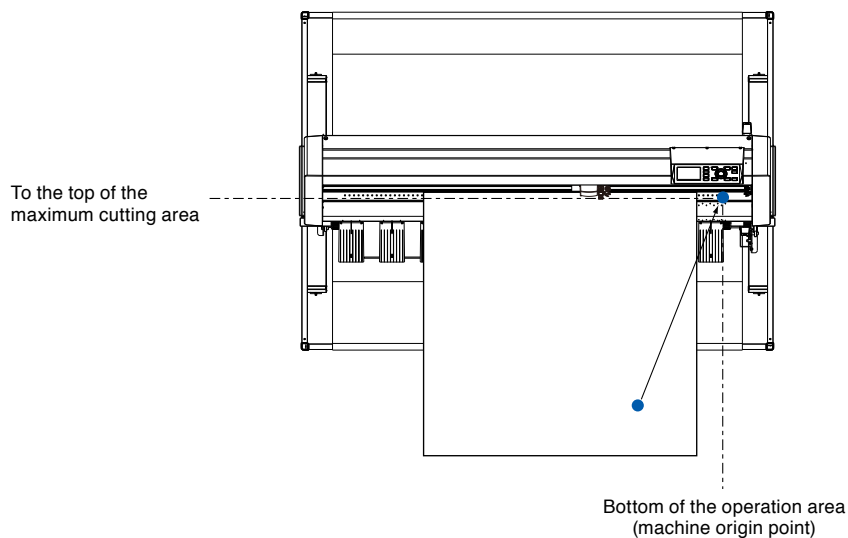

Operation

- 1 Press the [1] key (VIEW) in READY status.
 - ▶ Tool carriage will move away.

Supplement

Tool carriage will move away to upper right by continuously performing the same operation.

To move the tool carriage to the origin point, do following:

Operation

- 1 Press the [2] key (HOME) in READY status.
 - ▶ Tool carriage will move to the origin point.

Change the Cutting Condition (Condition No.)

Go through the following steps to change the Cutting Condition (Condition No.):

Operation

- 1 Press the [ENTER] key in READY status.

▶ CONDITION No. selection screen is displayed.



- 2 Press the [1] key (No.1), the [2] key (No.2), the [3] key (No.3), the [4] key (No.4), the [▲] key (No.5), the [▼] key (No.6), the [◀] key (No.7), or the [▶] key (No.8), while simultaneously pressing the [ENTER] key.

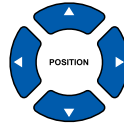

▶ Setting will be set, and it will return to default screen.

Supplement

It will return to state when the power is turned on when the [ORIGIN] key (RESET) is pressed. Please refer to [P.3-6](#) for Reset (Revert to the initial state when the power was turned on.).

Reset (Revert to the initial state when the power was turned on.)

To move to the position as after the power was turned on, do following:

Operation

- 1 Press the [ENTER] key in READY status.

▶ CONDITION No. selection screen is displayed.

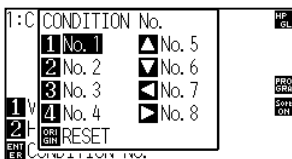

- 2 Press the [ORIGIN] key (RESET), while simultaneously pressing the [ENTER] key.

▶ Initialization is performed, and SELECT screen is displayed.

Supplement

Perform the settings in Normal menu.

3.3

Setting the Origin Point

Point where the cutting starts is called origin point. The origin point can be set at any location.

<When using Roll Media >

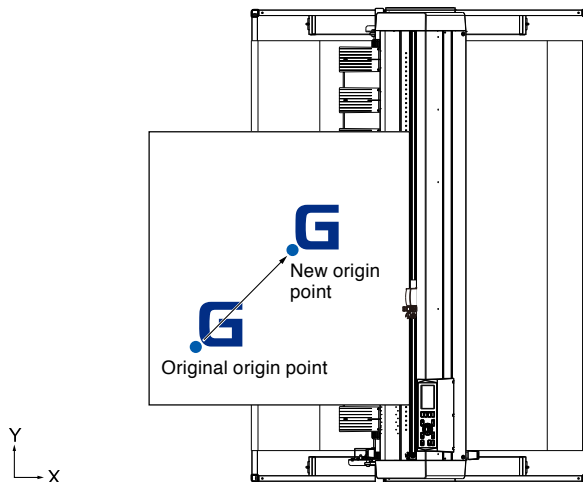

Operation

- 1 Move the tool to the new origin point by pressing the POSITION (▲▼◀▶) key when it is in READY status.

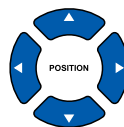

- 2 Press the [ORIGIN] key.

- ▶ New origin point is set, and "NEW ORIGIN POINT IS SET !" is displayed for few seconds in the screen.



Supplement

An Initial feed will be performed when initial feed is set to ON and the [ORIGIN] key is pressed. For more information on media settings and automatic pre feeds, see "Initial Feed" [P.7-6](#).

When Coordinate Axes Rotation are Set

If the origin point is moved while the coordinate axes are rotated, the origin point will move as shown below.

Supplement

See "Setting the Cutting Direction" [P.3-10](#) about the rotation of the coordinate axes.

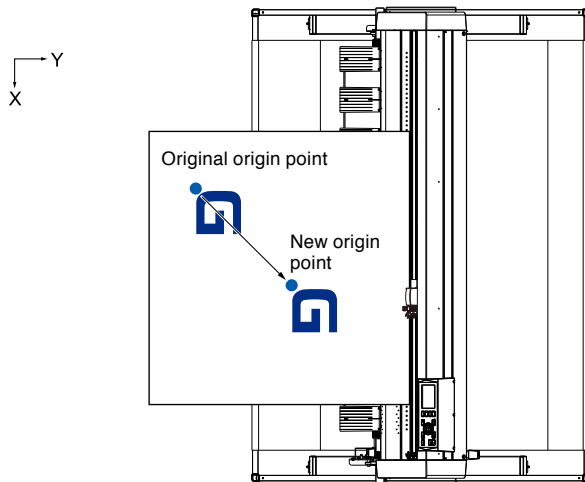

When Coordinate Axes are Rotated After Origin Point is Set

The origin point will be initialized as shown below if the coordinate is rotated after moving the origin point. Distance "a" will be maintained, but distance "b" will be initialized.

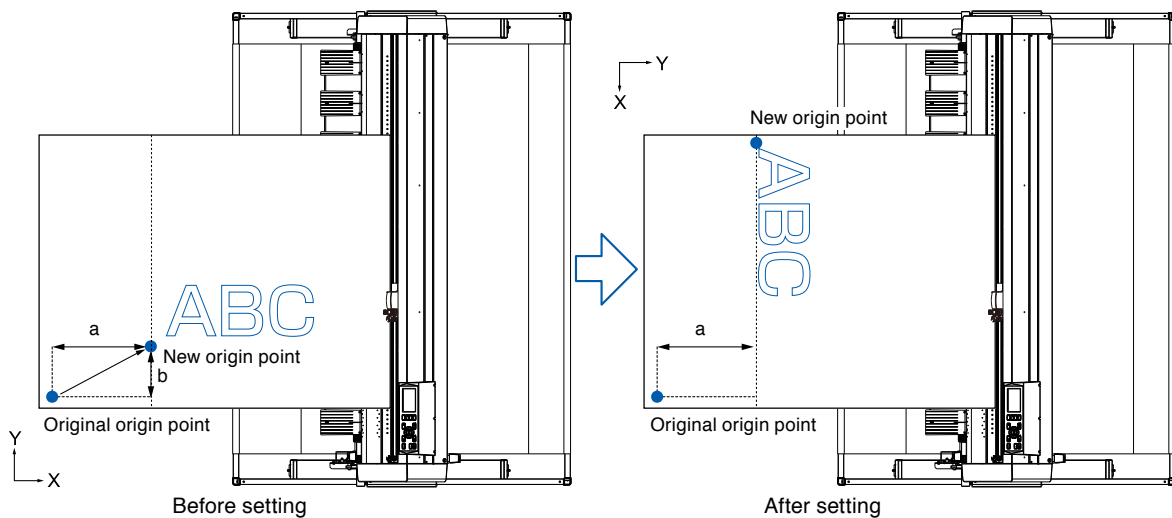

Supplement

- To use the origin point movement and coordinate axes rotation together, always rotate the coordinate axes first, and then move the origin point.
- Coordinate value displayed after setting new origin point is a distance from the new origin point.

Setting Origin Point When HP-GL is Set

When using the HP-GL command, the origin point is set to either the lower left of the cutting area or the center.

Supplement

- When using the GP-GL command, this setting does not affect the operation.
- See "Settings of Controls from Computer" [P.10-1](#) about setting the COMMAND.

Operation

- 1 Press the [PAUSE/MENU] key.

▶ MENU screen is displayed.



- 2 Press the POSITION (▲) key.

▶ INTERFACE screen (1/3) is displayed.

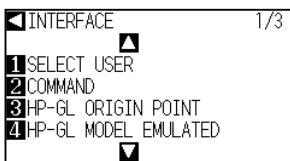

- 3 Press the [3] key (HP-GL ORIGIN POINT).

▶ HP-GL ORIGIN POINT setting screen is displayed.

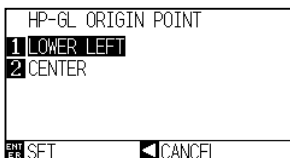

- 4 Press the [1] key (LOWER LEFT) or the [2] key (CENTER).

- 5 Confirm the setting and press the [ENTER] key (SET).

▶ Setting will be set, and it will return to I/F screen.

- 6 Press the [PAUSE/MENU] key.

▶ It will return to the default screen.

Supplement

Perform the settings in Normal menu.

Supplement

It will return to I/F screen without changing the settings when you press the POSITION [◀] key (CANCEL).

3.4

Setting the Cutting Direction

Rotate the coordinate axes to change the cutting direction.

Reference

The rotation settings will be saved even if the power is shut off.

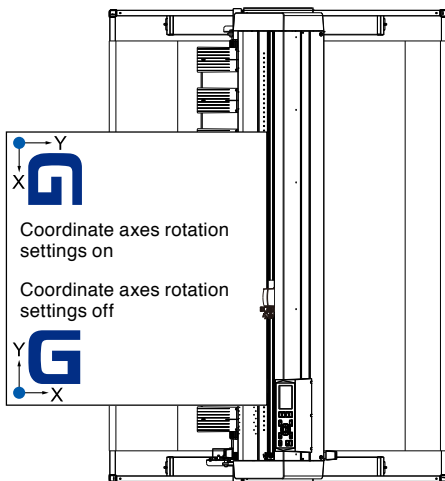

Operation

- 1 Press the [PAUSE/MENU] key.

▶ MENU screen is displayed.



- 2 Press the [3] key (AREA).

▶ AREA PARAMETERS setting screen (1/1) is displayed.

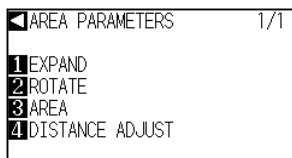

- 3 Press the [2] key (ROTATE).

▶ ROTATE screen is displayed.

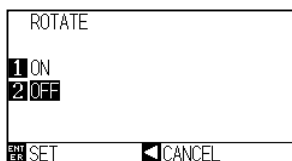

- 4 Press the [1] key (ON) or the [2] key (OFF).

Supplement

Perform the settings in Normal menu.

- 5 Confirm the setting and press the [ENTER] key (SET).
 - ▶ Setting will be set, and it will return to AREA PARAMETERS screen (1/1).

- 6 Press the [PAUSE/MENU] key.
The tool carriage moves to the coordinate position you set.
 - ▶ It will return to default screen.

Supplement

It will return to AREA PARAMETERS setting screen (1/1) without changing the settings when you press the POSITION (◀) key (CANCEL).

3.5

Stop Cutting

It will stop cutting when the [PAUSE/MENU] key is pressed while cutting. Operation selection menu is displayed on the screen of the control panel while it is stopped. It is possible to choose either to continue or stop the operation.

It is also possible to exchange or reset the media while it is stopped.

Pause and Resume Cutting

Operation

1 Press the [PAUSE/MENU] key.

▶ Cutting will stop and following screen is displayed.

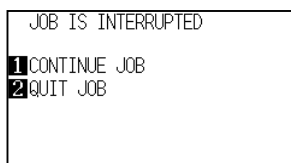

2 Perform necessary operation, such as exchanging the media.

Supplement

There is no effect on the selection of media type when the media set lever is moved up and down while pausing the cutting. It is also possible to exchange or reset the media.

3 Press the [1] key (CONTINUE JOB).

▶ Cutting will start and the screen will resume to operation.

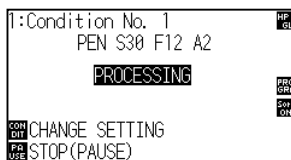

Supplement

It will stop cutting by pressing [2] key (QUIT JOB).

See "Stop Cutting" [▶ P.3-13](#) .

Stop Cutting

Operation

1 Press the [PAUSE/MENU] key.

▶ Operation will stop and following screen is displayed.

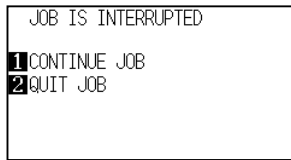

2 Press the [2] key (QUIT JOB).

▶ Following screen is displayed.

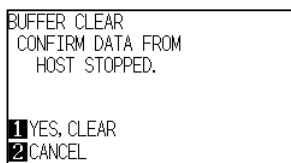

3 Confirm if the data transfer from the computer is stopped and press the [1] key (YES, CLEAR).

▶ Following screen is displayed, the buffer memory is cleared, and it will return to default screen.

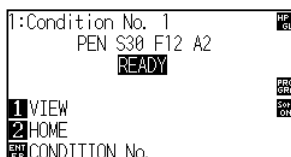

Supplement

It will resume cutting by pressing [1] (CONTINUE JOB) key.

See "Pause and Resume Cutting" [↪ P.3-12](#).

Supplement

- It will return to operation stop screen without clearing buffer memory when [2] key (CANCEL) is pressed.
- In the case that the operation is interrupted and the buffer is cleared, make sure that the data transfer is stopped. If the data transfer continues, abnormal operations where data is processed from the middle may occur.

Chapter 4: Convenient Functions

This chapter describes about the convenient functions of the plotter.

PRODUCT SUMMARY

- 4.1 Settings for Cutting**
- 4.2 Copy (Duplicate Cutting)**
- 4.3 Panel Cutting**
- 4.4 Setting a cross cut**
- 4.5 Setting a cut (F_CUT) for F command**
- 4.6 Setting a force for cross cut**

4.1

Settings for Cutting

Settings such as area and width of cutting, page length, mirrored, enlarged, shrunk, etc., can be set.

Setting Cutting Area

Origin point will be set at lower left of the AREA once the AREA is set. It is possible to set the origin point at the center when the HP-GL is selected.

Move the origin point to change the cutting position.

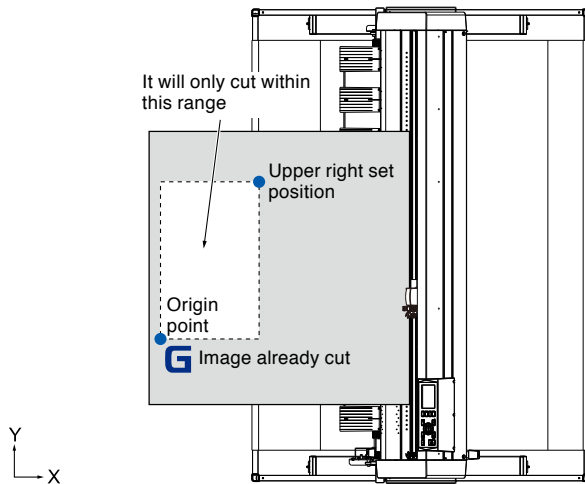

Supplement

- See "Setting the Origin Point" [P.3-7](#) about the moving the origin point.
- See "Setting Origin Point When HP-GL is Set" [P.3-9](#) for setting the origin point with HP-GL command.

Operation

- 1 Press the [PAUSE/MENU] key in READY status.

▶ MENU screen is displayed.



- 2 Press the [3] key (AREA).

▶ AREA PARAMETERS setting screen (1/1) is displayed.

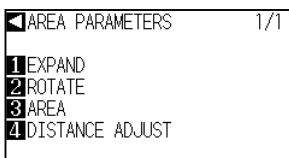

- 3 Press the [3] key (AREA).

▶ SET LOWER LEFT screen is displayed.

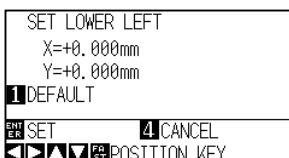

Supplement

- Perform the settings in Normal menu.
- See "How to Use Control Panel" [P.2-21](#) for READY status.

Supplement

- Coordinate value displayed here is the distance to the tool carriage from the origin point.
- Press [1] key (DEFAULT) if the cutting area is not to change.

- 4 Press the POSITION (▲▼◀▶) key and move the tool carriage to the position to be the lower left of the AREA.

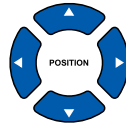

- 5 Press the [ENTER] key (SET) once the tool carriage is in correct position.

▶ SET UPPER RIGHT screen is displayed.

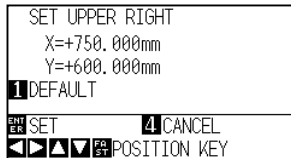

- 6 Press the POSITION (▲▼◀▶) key and move the tool carriage to the upper right position of the AREA.

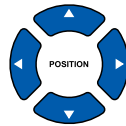

- 7 Press the [ENTER] key (SET) once the tool carriage is in correct position.

▶ Setting will be set, and it will return to AREA PARAMETER screen (1/1).

- 8 Press the [PAUSE/MENU] key.

▶ It will return to default screen.

Supplement

Please set the X and Y cut range for the areas on the upper right and lower left points to at least 10 mm.

An error message will appear for areas that are too small.



You will need to reset the settings for the upper right and lower left points.

Supplement

It will return to AREA PARAMETERS setting screen (1/1) without changing the settings when you press the [4] key (CANCEL).

Setting Cutting Width (EXPAND)

Set the cutting width. It is possible to set that it will cut to the area outside of the push rollers, or not to cut at the ends of the media.

Default setting is to the internal edge of the push rollers. It can be set up to 10 mm* outside (positive value) or 10 mm inside (negative value) from the default position. The width will enlarge if the value is set to positive, and the width will decrease if the value is set to negative. Setting will affect both ends, resulting the total width change will be double the set value.

- * The value of the left-hand margin when using the left grit roller are as follows;
When the left grid roller is used, it does not spread to positive towards the left-hand.
Even if the value between +1 and +10 is set, the left-hand margin will be 0.

Media size	Making an expand setting			
	0 (Default)		+10 mm	
	Left-hand	Right-hand	Left-hand	Right-hand
1201 mm to 1220 mm	0	0	0	10 mm

CAUTION

Do not set the "INITIAL BLADE CONTROL POSITION" of the tool setting to "OUTSIDE" when the setting value is set to more than 8 mm. The blade might be damaged by moving the carriage outside the media under this condition.

Supplement

- If the value is set to positive, it is able to cut over where the push rollers are, but the push rollers passes where it is cut, creating a chance of bad feeding depending on the media.
- Set the width of cutting area, and then send the cutting data to the plotter. Cutting data in the buffer memory will be cleared when cutting area width is changed.

Operation

- 1 Press the [PAUSE/MENU] key in READY status.

▶ MENU screen is displayed.



Supplement

- Perform the settings in Normal menu.
- See "How to Use Control Panel" → P.2-21 for READY status.

- 2 Press the [3] key (AREA).

▶ AREA PARAMETERS setting screen (1/1) is displayed.

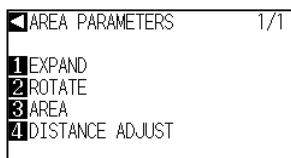

- 3 Press the [1] key (EXPAND).

▶ SET EXPAND LIMIT setting screen is displayed.

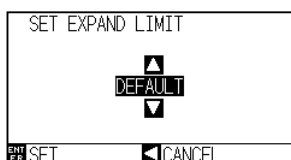

- 4 Press the POSITION (▲▼) key and increase or decrease the setting value.

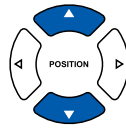

Supplement

- If the settings value is set to an area between +1.0 mm and +10.00 mm, transfer direction of the cutting area will also expand 5 mm forward.
- The default area which can be set is +10.0 to -10.0 mm.

- 5 Confirm the setting and press the [ENTER] key (SET).

- ▶ Setting will be set, and it will return to AREA PARAMETERS setting screen (1/1).

Supplement

It will return to AREA PARAMETER screen (1/1) without changing the settings when you press the POSITION (◀) key (CANCEL).

- 6 Press the [PAUSE/MENU] key.

- ▶ It will return to default screen.

Setting Length of the Page

Length of 1 page when using the roll media is set.

Only the part that will fit in to the set page length will be cut for the cutting data that is longer than the set page length, and the exceeding part will not be cut.

Reference

- Default page length is 3 m. When doing long cuts, set the page length. Check the setting of the page length when cutting long length.
 - * Be sure to use the basket.
- For the CE6000-120AP, the page length up to 50 m can be set. We give quality assurance for page feeding up to 3 m. (Under the condition that the media described below is used.)
 - Be sure to use the basket.
 - Media: genuine Graphtec brand products
 - Setting Conditions: Speed under 30, acceleration under 2.
 - Perform pre feed for the amount to be used before cutting.
 - Leave the media in environment to use for adequate time if the deviation of temperature and humidity is big.
 - Set the both push rollers at least 15mm inside the edge of media.
 - The paper needs to be reset after cutting 5 consecutive pages.
 - Each page should be removed from the basket after it has been cut.
- When setting media for long-plotting, set the tension on the left and right of the width of the media to a uniform value. If it is not uniform, the media may be removed from the roller that presses it during plotting.
- Make sure to level the whole of the media to get rid of unevenness before cutting. (See "Setting the number of pre feeds" [▶P.4-7](#)). Also, pre feeding can be done automatically when the data is received (see "Perform Automatic Pre Feed When Cut Data is Received" [▶P.7-4](#)), or done automatically when the media is loaded (see "Perform Automatic Pre Feed When Media is Set (Initial Feed)" [▶P.7-6](#)).
 - * Pre feeding will stabilize the feed by acclimating the media, taking out the slack.
- This setting is maintained even after the power is turned off.

Operation

- 1 Press the [PAUSE/MENU] key.

- ▶ MENU screen is displayed.



MENU screen
(Normal menu)

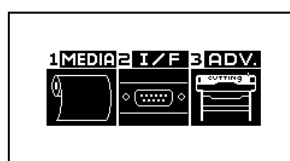

MENU screen
(Simple menu)

2 Press the [4] key (MEDIA) in Normal menu, or press the [1] key (MEDIA) in Simple menu.

▶ MEDIA SETTING screen is displayed.

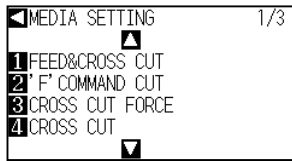

MEDIA SETTING screen (Normal menu)

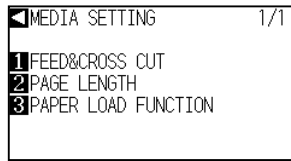

MEDIA SETTING screen (Simple menu)

3 Press the POSITION (▲) key in Normal menu.

▶ MEDIA SETTING screen (2/3) is displayed.

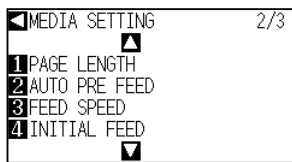
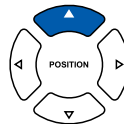

MEDIA SETTING screen (Normal menu)

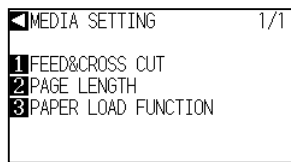

MEDIA SETTING screen (Simple menu)

4 Press the [1] key (PAGE LENGTH) in Normal menu, or press the [2] key (PAGE LENGTH) in Simple menu.

▶ PAGE LENGTH screen is displayed.

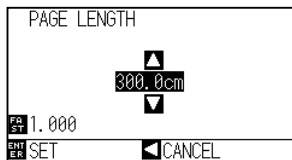

5 Press the POSITION (▲▼) key and increase or decrease the setting value.

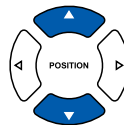

6 Confirm the setting and press the [ENTER] key (SET)

▶ Setting will be set, and it will return to MEDIA SETTING screen (1/2).

7 Press the [PAUSE/MENU] key.

▶ It will return to default screen.

Supplement

- Digits of settings can be changed by pressing the [FAST] key.
- Setting range is from 20.0 cm to 5000.0 cm.
- The following screen will display if using a setting greater than 500 cm.

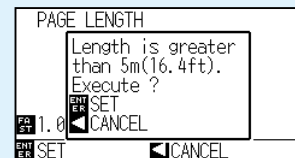

After confirming, press the [ENTER] key.

Supplement

It will return to MEDIA SETTING screen without changing the settings when you press the POSITION (◀) key (CANCEL).

Setting the number of pre feeds

Set the number of pre feeds to prevent deviations from occurring when the roll media is pulled out. During the pre feed, the grit roller leaves traces on the paper. Pre feeds can be repeated after paper exposure time has elapsed (see "Setting paper ready time" [▶ P.4-8](#)). This function is available when the Initial Feed or if Partition Pastern is ON.

Operation

- 1 Press the [PAUSE/MENU] key.

▶ MENU screen is displayed.



MENU screen
(Normal menu)

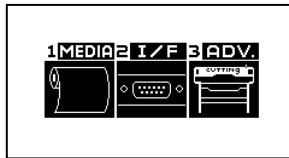

MENU screen
(Simple menu)

Supplement

Perform the settings in Normal menu.

- 2 Press the [4] key (MEDIA) in Normal menu, or press the [1] key (MEDIA) in Simple menu.

▶ MEDIA SETTING screen is displayed.

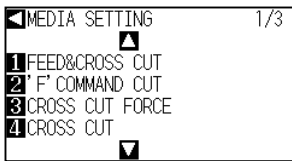

MEDIA SETTING screen
(Normal menu)

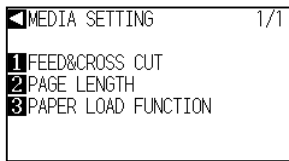

MEDIA SETTING screen
(Simple menu)

- 3 Press the POSITION (▼) key in Normal menu.

▶ MEDIA SETTING screen (3/3) is displayed.

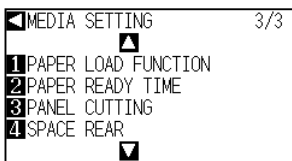
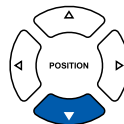

MEDIA SETTING screen
(Normal menu)

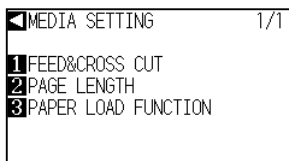

MEDIA SETTING screen
(Simple menu)

- 4 Press the [1] key (PAPER LOAD FUNCTION) in Normal menu, or press the [3] key (PAPER LOAD FUNCTION) in Simple menu.

▶ PAPER LOAD FUNCTION setting screen is displayed.

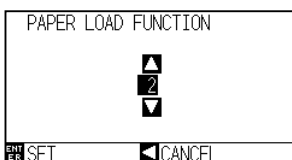

- 5 Press the POSITION (▲▼) keys to change the current setting.

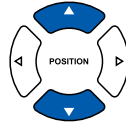

Supplement

- You can set between 0 and 5.
- Cutting/plotting will begin immediately after the pre feed is complete and data sent during paper exposure time is received.

- 6 Confirm the setting and press the [ENTER] key (SET)
 ▶ Setting will be set, and it will return to MEDIA SETTING screen (1/2).

Supplement

It will return to MEDIA SETTING screen without changing the settings when you press the POSITION (◀) key (CANCEL).

- 7 Press the [PAUSE/MENU] key.
 ▶ It will return to default screen.

Setting paper Ready time

This function sets the time the paper/media is acclimated to the operating environment after being pulled off the paper roll to minimize media expansion or contraction, and prevent it from adversely effecting cutting or plotting. After the initial feed is complete, the paper will be fed backwards to half the preset feed length and exposed for the set amount of time.

This function is available when the Initial Feed or if Panel Cutting is ON.

Operation

- 1 Press the [PAUSE/MENU] key in READY status.
 ▶ MENU screen is displayed.



Supplement

- Perform the settings in Normal menu.
- For the READY status, see "How to Use Control Panel" → P.2-21.

- 2 Press the [4] key (MEDIA).
 ▶ MEDIA SETTING screen (1/3) is displayed.

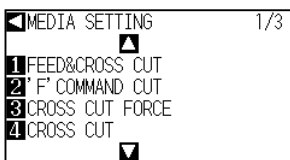

- 3 Press the POSITION (▼) key.
 ▶ MEDIA SETTING screen (3/3) is displayed.

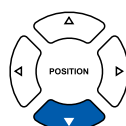
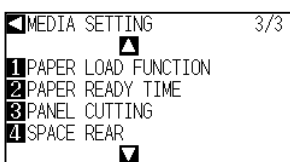

4 Press the [2] key (PAPER READY TIME).

▶ PAPER REDY TIME setting screen is displayed.

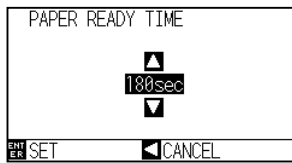

5 Press the POSITION (▲▼) key and increase or decrease the setting value.

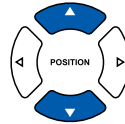

Supplement

Paper exposure time can be set to 0, 60, 120, 180, 300, 420, or 600 seconds.

6 Confirm the setting and press the [ENTER] key (SET).

▶ Setting will be set, and it will return to MEDIA SETTING screen (3/3).

Supplement

Press the POSITION (◀) (CANCEL) key to return to the MEDIA SETTING screen (3/3) without changing any settings.

7 Press the [PAUSE/MENU] key.

▶ It will return to default screen.

Setting the space rear

This setting allows a cross cut to be made from the maximum value of the cut along the X axis based on the rear margin setting during time out or when making a cross cut across a separator.

Operation

1 Press the [PAUSE/MENU] key in READY status.

▶ MENU screen is displayed.



Supplement

- Perform the settings in Normal menu.
- For the READY status, see "How to Use Control Panel" → P.2-21.

2 Press the [4] key (MEDIA).

▶ MEDIA SETTING screen (1/3) is displayed.

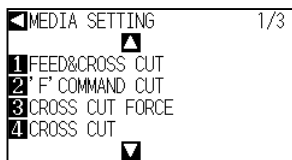

3 Press the POSITION (▼) key.

▶ MEDIA SETTING screen (3/3) is displayed.

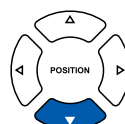
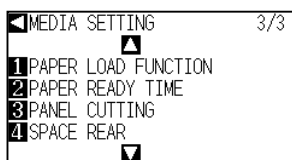

4 Press the [4] key (SPACE REAR).

▶ SPACE REAR setting screen is displayed.

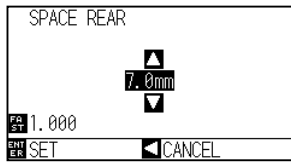

5 Press the POSITION (▲▼) key and increase or decrease the setting value.

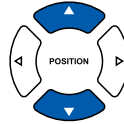

Supplement

- Press the [FAST] key to change the setting digits.
- The rear margin can be set between 7.0 mm to 30.0 mm.

6 Confirm the setting and press the [ENTER] key (SET).

▶ Setting will be set, and it will return to MEDIA SETTING screen (3/3).

Supplement

Press the POSITION (◀) (CANCEL) key to return to the MEDIA SETTING screen (3/3) without changing any settings.

7 Press the [PAUSE/MENU] key.

▶ It will return to default screen.

4.2

Copy (Duplicate Cutting)

The function to cut specified numbers of cutting data stored in the buffer memory is called COPY.

Supplement

- Do not send new data to plotter while copying. Cutting data in the buffer memory will be cleared.
- Previous cutting data will be cleared and newly sent data will be stored as cutting data if you send new data with 10 seconds or more interval from the time it finished cutting.
- It can not copy if data is more than 1.6 MB because it cannot be stored in the buffer memory of the plotter.
- Buffer memory that can be used for copy will decrease if you turn on the data sort. Turn off the data sort when you need to copy cutting with large data. See "Sorting the Cutting Data" [P.7-2](#) for data sort.
- Watch out that it does not fall out of media when cutting with copy function.
- If the original cutting data to be copied starts away from the origin point, copied cutting will also start away from the origin point. To avoid wasted space, create the cutting data close to the origin point.
- Alignment registration mark data cannot be copied.

When Media Change mode is off

Copy is performed in following order.

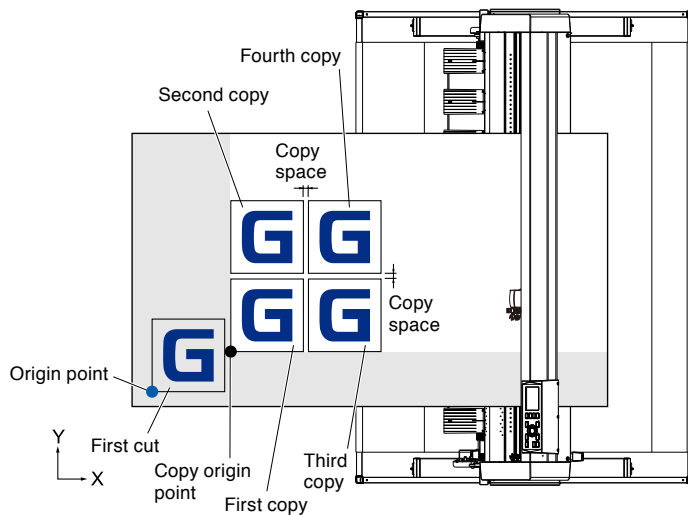

It will copy in following order when COORDINATE AXES ROTATION is set.

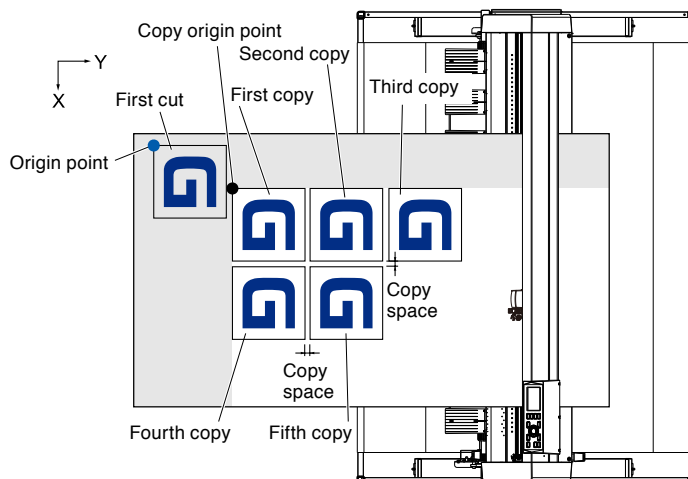

Operation

1 Create one data you want to copy.

▶ Cutting data is stored in the buffer memory.

2 Press the POSITION (▲▼◀▶) key and move the tool carriage to the position to copy.

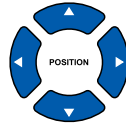

3 Press the [COPY] key.

▶ COPY MODE screen is displayed.

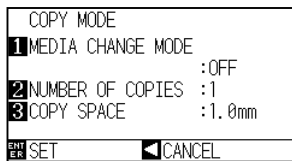

4 Press the [1] key (MEDIA CHANGE MODE).

▶ MEDIA CHANGE MODE setting screen is displayed.

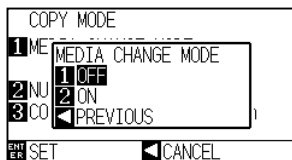

5 Press the [1] key (OFF).

▶ Confirm the settings and return to the COPY MODE screen.

6 Press the [2] key (NUMBER OF COPIES).

▶ NUMBER OF COPIES setting screen is displayed.

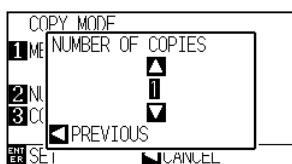

7 Press the POSITION (▲▼) key and increase or decrease the setting value.

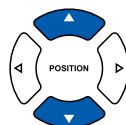

8 Confirm the setting and press the POSITION (◀) key (PREVIOUS).

▶ Number of copies will be selected, and it will return to COPY mode screen.

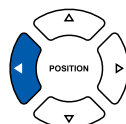

Supplement

- When setting the copy interval, set "MEDIA CHANGE MODE" to OFF.
- "NO DATA FOR COPY IN BUFFER!" is displayed if there is no data in the buffer memory. Send the cutting data.
- If too much data is sent from the buffer memory, "1 copy in the Copy mode buffer!" will be displayed.
- If the data to be copied is larger than the cutting area, "Cannot copy, the valid area is too small!" will be displayed.

Supplement

- Number of copies can be set from 1 to 100, as much as it can fit in the media set on the printer.
- The initial value for the number of copies is always 1.

Supplement

"CANNOT COPY CUT AREA TOO SMALL!" is displayed if the cutting area is smaller than the copy data. Either expand the cutting area, or set the media that is big enough to copy.

9 Press the [3] key (COPY SPACE).

▶ COPY SPACE setting screen is displayed.

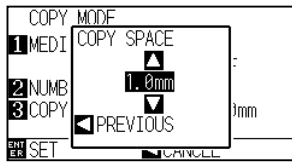

Supplement

- Copy interval can be set when MEDIA CHANGE MODE is turned off.
- Copy space can be set from 1.0 mm to 10.0 mm.
- This setting is maintained even if the power is turned off.

10 Press the POSITION (▲▼) key and increase or decrease the setting value.

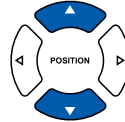

11 Confirm the setting and press the POSITION (◀) key (PREVIOUS).

▶ Copy space will be selected, and it will return to COPY MODE screen.

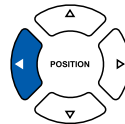

12 Confirm the setting and press the [ENTER] key (SET).

▶ "COPY" is displayed on the screen, and it will copy as much as specified.

Supplement

Cutting data is stored even if the media is exchanged. It can be copied as many times until the buffer memory is cleared. It can be copied again after exchanging the media by pressing [COPY] key.

When Media Change mode is on

The Change Media message appears each time when ending a single cut in Media Change mode. Choosing to change media will instantly detect the media and proceed to a copy area (cut). Media switch copies can be made up to the set copy number (designated number).

Operation

- 1 Create one data you want to copy.
 - ▶ Cutting data is stored in the buffer memory.

- 2 Press the [COPY] key.
 - ▶ COPY MODE screen is displayed.

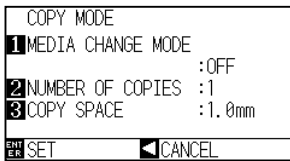

- 3 Press the [1] key (MEDIA CHANGE MODE).
 - ▶ MEDIA CHANGE MODE setting screen is displayed.

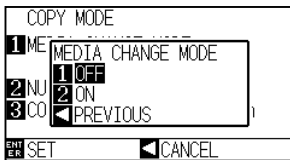

- 4 Press the [2] key (ON).
 - ▶ Confirm the settings and return to the COPY MODE screen.

- 5 Press the [2] key (NUMBER OF COPIES).
 - ▶ NUMBER OF COPIES setting screen is displayed.

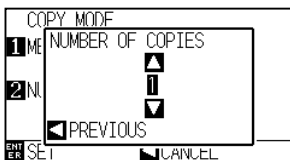

- 6 Press the POSITION (▲▼) key and increase or decrease the setting value.

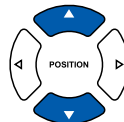

Supplement

- Turning MEDIA CHANGE MODE on will display the CHANGE MEDIA message each time after a single cut.

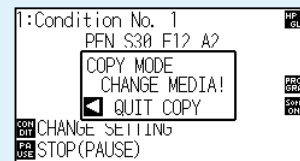

"If the POSITION (◀) key (QUIT COPY) is pressed, copying will be suspended and it will return to the default screen.

- When exchanging media, the media selection will be chosen from what was selected before copying.
- If there is no data in the buffer memory, "There is no data for copying in the buffer" will be displayed. Please send cutting data.
- If too much data is sent from the buffer memory, "1 copy in the Copy mode buffer!" will be displayed.

Supplement

It will return to COPY MODE screen without changing the settings when you press the POSITION (◀) key (PREVIOUS).

Supplement

The copy number can be set from 1 to 100.

7 Confirm the setting and press the POSITION (◀) key (PREVIOUS).

▶ Copy space will be selected, and it will return to COPY MODE screen.

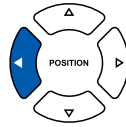

Supplement

"CANNOT COPY CUT AREA TOO SMALL!" is displayed if the cutting area is smaller than the copy data. Either expand the cutting area, or set the media that is big enough to copy.

8 Confirm the setting and press the [ENTER] key (SET).

▶ "COPY MODY CHANGE MEDIA!" will be displayed on the screen.

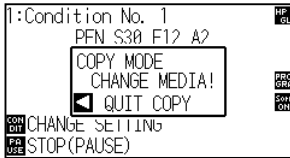

Supplement

Cutting data is stored even if the media is exchanged. It can be copied as many times until the buffer memory is cleared. It can be copied again after exchanging the media by pressing [COPY] key.

9 Replace the media.

▶ The plotter starts a copy immediately after replacing the media.

This operation's specified number of copies will be repeated.
In the case of suspension, press the POSITION (◀) key (QUIT COPY).

4.3

Panel Cutting

To prevent long skew, utilize partition length when cutting.

Supplement

- When Partition Pastern is on, the machine will begin by dividing up partition length and continue cutting until one of the following data breaks appears. When the first partitioned area cut is finished, the machine will move to the next area, and repeat this until all areas have been cut.
- Data Breaks:
 - (1) No data sent for a few second after finishing cutting. (Time Out)
 - (2) A feed-related command is set. (GP-GL: F, FS commands, HP-GL: AF, AH, PG commands)
 - (3) HP-GL: SP0, NR, GP-GL: J0, SO.
 - (4) When commands from data breaks (2) and (3) appear, that command work will begin after the partition pastern cutting is finished.
- Partition pastern cutting will continue for each piece of data when a data break is caused by a command, even if multiple pieces of data are sent in before the cutting finishes (even when numerous pieces of partition pastern data are in the plotter buffer).
- When partition pastern is on, the machine works with priority of partition length plus something minutes ago (with footprints).
- When partition pastern is on, and registration marks will not be seen ignored, and copy, initial feed, and cutting area cannot be changed.
- Partition pastern cannot be done when one file of data makes the buffer full. Make sure to always send in data lower than the buffer size.
- When Partition Pastern is on, the paper will be exposed for a set amount of time after the initial feed is complete, and then pre-fed the set number of pre feeds. (This will not happen if paper exposure time and number of pre feeds are both set to 0.)
- When Partition Pastern is on, set the cutting/plotting speed to 30 cm/s.

Reference

This setting will be saved even if the power is shut off.

Operation

1 Press the [PAUSE/MENU] key.

▶ MENU screen is displayed.



2 Press the [4] key (MEDIA).

▶ MEDIA SETTING screen (1/3) is displayed.

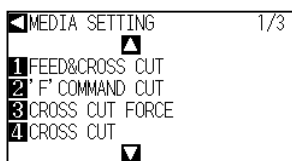

Supplement

Perform the settings in Normal menu.

3 Press the POSITION (▼) key

▶ MEDIA SETTING screen (3/3) is displayed.

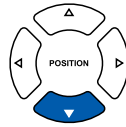
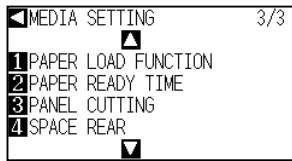

4 Press the [3] key (PANEL CUTTING).

▶ PANEL CUTTING screen is displayed.

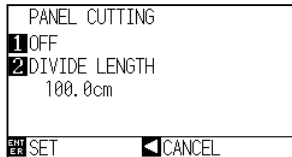

5 Press the [1] key (OFF).

▶ PANEL CUTTING setting screen is displayed.

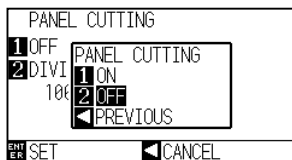

6 Press the [1] key (ON), or the [2] key (OFF).

▶ Confirm the settings and return to the PANEL CUTTING screen.

7 Press the [2] key (DIVIDE LENGHT).

▶ DIVIDE LENGHT setting screen is displayed.

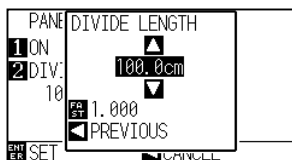

8 Press the POSITION (▲▼) key and increase or decrease the setting value.

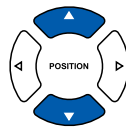

9 Confirm the setting and press the [ENTER] key (SET).

▶ Confirm the settings and return to the MEDIA SETTING screen (3/3).

10 Press the [PAUSE/MENU] key.

▶ It will return to default screen.

Supplement

- Press the [FAST] key to change the setting digits.
- The partition length can be set from 1.0 to 2000.0 cm.

Supplement

It will return to MEDIA SETTING screen (3/3) without changing the settings when you press the POSITION (◀) key (CANCEL).

4.4

Setting a cross cut

Using the values set with the command and timeout specified in separator, set whether performing cross cut or not.

➔ P.8-8 "Setting a separator"

➔ P.8-11 "Setting a timeout"

Reference

This setting will be saved even if the power is shut off.

Operation

1 Press the [PAUSE/MENU] key.

▶ MENU screen is displayed.



2 Press the [4] key (MEDIA).

▶ MEDIA SETTING screen (1/3) is displayed.

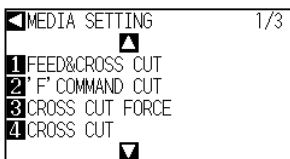

3 Press [4] key (CROSS CUT).

▶ CROSS CUT screen is displayed.

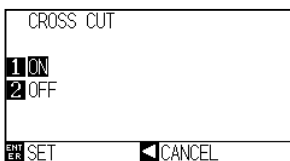

4 Press [1] key (ON) or [2] key (OFF).

5 Confirm the setting and press the [ENTER] key (SET).

▶ Confirm the settings and return to the MEDIA SETTING screen (1/3).

6 Press the [PAUSE/MENU] key.

▶ It will return to default screen.

Supplement

Perform the settings in Normal menu.

Supplement

It will return to MEDIA SETTING screen (1/3) without changing the settings when you press the POSITION (◀) key (CANCEL).

4.5

Setting a cut (F_CUT) for F command

When using the GP-GL command, using the feed command, you can set whether performing cross cut or not. In this function, even if the parameter that do not cut the media with the feed command is sent, the cross cut will be performed.

Reference

This setting will be saved even if the power is shut off.

Operation

1 Press the [PAUSE/MENU] key.

▶ MENU screen is displayed.



2 Press the [4] key (MEDIA).

▶ MEDIA SETTING screen (1/3) is displayed.

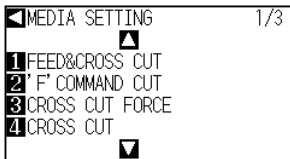

3 Press [2] key ('F' COMMAND CUT).

▶ 'F' COMMAND CUT screen is displayed.

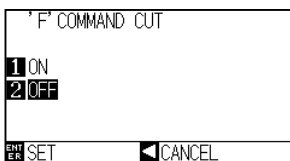

4 Press [1] key (ON) or [2] key (OFF).

5 Confirm the setting and press the [ENTER] key (SET).

▶ Confirm the settings and return to the MEDIA SETTING screen (1/3).

6 Press the [PAUSE/MENU] key.

▶ It will return to default screen.

Supplement

Perform the settings in Normal menu.

Supplement

It will return to MEDIA SETTING screen (1/3) without changing the settings when you press the POSITION (◀) key (CANCEL).

4.6

Setting a force for cross cut

This allows you to adjust the blade force for cross cut.

The setting range for cross cut is between 1 and 38. The larger the set value, the stronger the force.

If the media is thin, set the smaller value and vice versa.

Reference

This setting will be saved even if the power is shut off.

Operation

- 1 Press the [PAUSE/MENU] key.

▶ MENU screen is displayed.



- 2 Press the [4] key (MEDIA).

▶ MEDIA SETTING screen (1/3) is displayed.

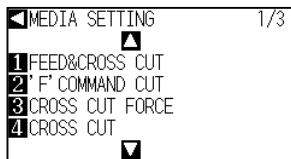

- 3 Press [3] key (CROSS CUT FORCE).

▶ CROSS CUT FORCE screen is displayed.

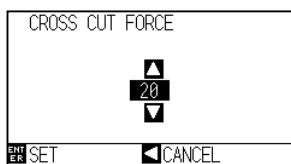

- 4 Press the POSITION (▲▼) keys to change the current setting.

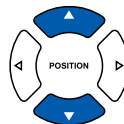

- 5 Confirm the setting and press the [ENTER] key (SET).

▶ Confirm the settings and return to the MEDIA SETTING screen (1/3).

- 6 Press the [PAUSE/MENU] key.

▶ It will return to default screen.

Supplement

Perform the settings in Normal menu.

Supplement

You can set the range between 1 to 38.

Supplement

It will return to MEDIA SETTING screen (1/3) without changing the settings when you press the POSITION (◀) key (CANCEL).

Chapter 5: Manual Position Adjust

Here, we will explain how to match up points while manually confirming the media and tool (cutter pen or plotting pen) points.

The ARMS function cannot be used for accurately matching up points.

PRODUCT SUMMARY

5.1 *Outline of Manual Position Adjust*

5.2 *Adjusting coordinate Axes*

5.1

Outline of Manual Position Adjust

For axis adjustment, the inclination of the axis can be adjusted based on the coordination of 2 grit and/or registrations marks. Furthermore, it's possible to adjust the distance by entering the distance of each point. Move the tip of each tool to the appropriate point.

Use media that has the plots (grits or alignment marks) required to find the X-Y axis and the origin.

Alignment registration mark

There are two alignment marks. The position of each alignment mark is shown in the next figure.

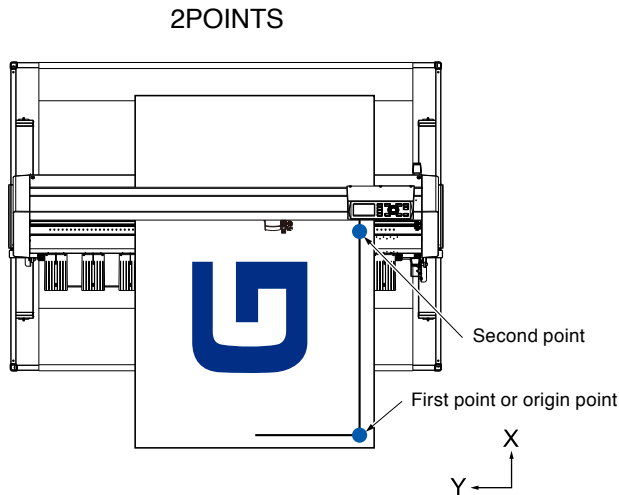

Example of axis adjustment

The pre and post adjustment grid appears as follows

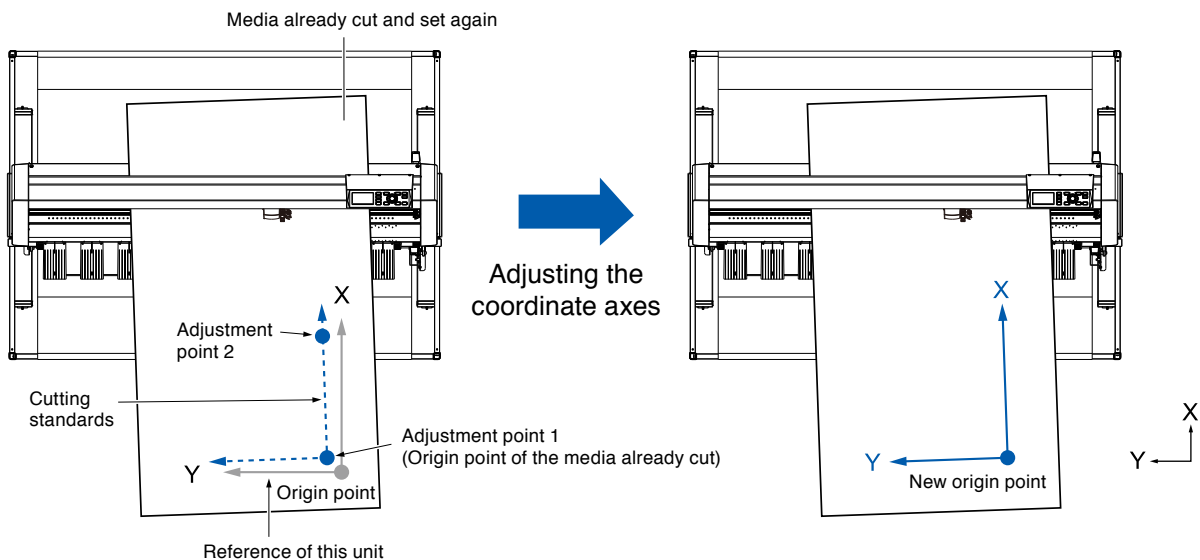

There is a deviation between the X-Y axis and origin point of the unit and the media plotted.

To eliminate the deviation, correct the deviations of the X-Y axis and origin point.

5.2

Adjusting coordinate Axes

The following explain how to adjust to coordinated axes.

Supplement

- Adjustment will be cleared if following is done after setting the adjustment.
 - Set new origin point.
 - Set the media again.
 - Set rotation or mirror. (Set the rotation or mirror prior to the axis adjustment)

Axis adjustment will convert in accordance with rotation or mirror in this case.

- When the inclination of the axis is too large when setting the first and second point, "Angle adjustment error, please reset" will be displayed. After setting the media so as to make the inclination small, please perform adjustment operations.
- Axis adjustment will be cleared when point 1 and point 2 is set to same point.

Setting the start point

Adjust plot deviations on the X and Y axis and origin point.

This function also makes it possible to re-plot paper that has already been cut.

Before adjusting the coordinate axes, please make sure to plot the line of the X Axis and the Origin point, so that it will be easier to tell where the Origin point and the coordinate axes are.

Please make sure to plot inside of the area parameters so that the machine can determine the line of the X axis and the origin point even if the media is tilted.

Please note that if you plot the Origin point and the X Axis very close to the plotting range, the set position will fall outside of the plotting range, meaning that adjustment will not be possible.

Operation

- 1 Load the media with adjustment mark in the plotter.
➡ P.2-7 Loading Media (Paper).

Supplement

Confirm that the push roller is steadily on the media within the range of media movement. This adjustment is based on assumption that media is slightly tilted. Media might fall off if the tilting of the media is too large.

- 2 Set a cutter plunger or a pen in the tool holder.

Supplement

Please take care when setting cutter plunger in the tool holder to position it front facing out in tool holder 1. For more information on attaching a tool, see "Attaching a tool" ➡ P.2-4 .

- 3 Press the [PAUSE/MENU] key.
▶ MENU screen is displayed.

Supplement

Perform the settings in Normal menu.



4 Press the [2] key (AXIS).

▶ AXIS ALIGNMENT screen (1/1) is displayed.

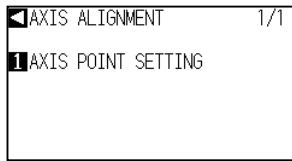

5 Press [1] key (AXIS POINT SETTING).

▶ The following message is displayed.



6 Press the POSITION (▲▼◀▶) keys to move the tip of the tool to the alignment registration mark position.

▶ Move the tool to adjustment point 1 (any point that is already plotted on the X axis).

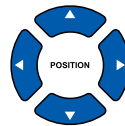

Supplement

Tool carriage will move faster when the [FAST] key is pressed simultaneously with the POSITION key.

7 Press [ENTER] key to check the tool position.

Supplement

Press the [4] key (CANCEL) to return to the default screen without reading.

8 Press the POSITION (▲▼◀▶) keys to move the tip of the tool to the alignment registration mark position.

▶ Move the tool to adjustment point 2 (any point that is already plotted on the X axis).

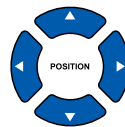
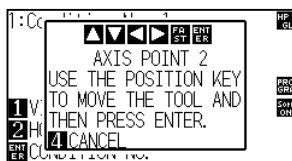

Supplement

Tool carriage will move faster when the [FAST] key is pressed simultaneously with the POSITION key.

9 Confirm the position of tool and then press [ENTER] key.

Supplement

Press the [4] key (CANCEL) to return to the default screen without reading.

10 Press the POSITION (▲▼◀▶) keys to move the tip of the tool to the alignment registration mark position.

▶ Move the tool to a new origin (the desired origin point).

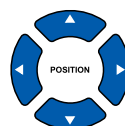
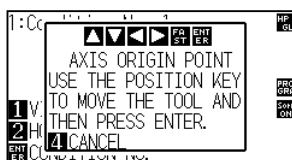

Supplement

Tool carriage will move faster when the [FAST] key is pressed simultaneously with the POSITION key.

11

Press the POSITION (▲▼◀▶) key, match the tool tip and move to the mark position.

- ▶ This will now measure the degree of the tilt on the X axis and make the necessary adjustments. Once the adjustments are complete, it will return you to the default screen.

Chapter 6:

Setting Regarding Cutting Quality

When actually plotting (cutting), there may be situations where it's not possible to plot (cut) ideally, or where lines are slightly off, corners are deformed, or uncut paper remains as a result of the characteristics of the media (its thickness or hardness) or the condition of the blade. Adjust the movement speed and the pressure on the tool and the control method in order to avoid this problem.

This chapter explains the settings for the quality of these types of plots (cuts).

PRODUCT SUMMARY

- 6.1 To cut the corner of thick media sharply***
- 6.2 Setting the Step Pass***
- 6.3 Setting the Offset Angle***
- 6.4 Setting the Distance Adjust***
- 6.5 Setting Initial Blade Control Position Adjust***
- 6.6 Settings for OFFSET FORCE***
- 6.7 Blade Wear Detection***
- 6.8 Adjust the space between tools 1 and 2***

6.1

To cut the corner of thick media sharply

Outline of TANGENTIAL MODE

The blade needs to be facing toward the direction of cut when cutting the media. The tip of the blade is shaped as shown so the blade is facing the cutting direction even when it is cutting curved lines or corners. The tip of the blade is off from the rotation axis of the blade (CUTTER OFFSET). The blade will automatically turn and face the cutting direction when the tool carriage moves, because the blade is forced to move from the rotation center, and the blade tip gets resistance by the media.

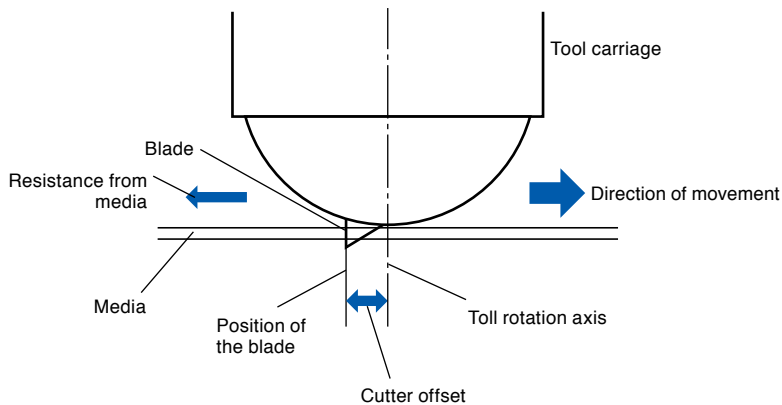

The blade tip gets sunk into the media with 0.3 mm or thicker, making the blade hard to rotate. Especially for the corners where two straight lines meet, cutting becomes very hard because it cannot rotate smoothly. Tangential mode is a control method to precisely cut corners where two straight lines meet. (See below) With the tangential mode, the blade is advanced so it will overcut at the corners before raising the tool. Then, it will be lowered at the position slightly before the next line, and start to cut with slight overcut.

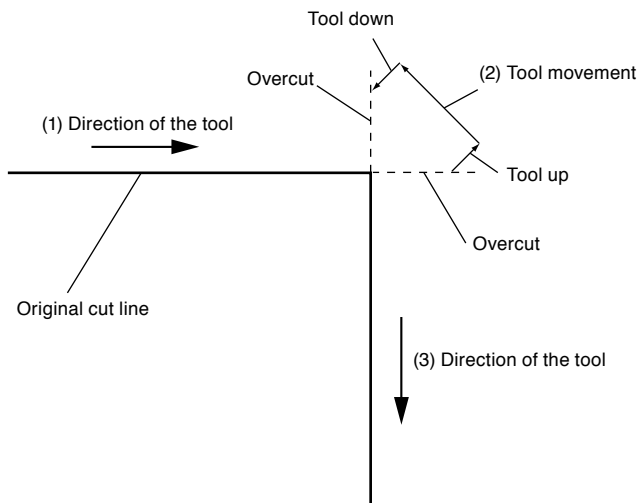

There are 2 modes for tangential mode.

Mode 1 : Overcuts the start and end points and acute-angle corners to eliminate uncut sections. In addition, the cutter blade is moved on the surface of the medium during cutting when it is rotated significantly, ensuring sharp cutting unaffected by the hardness or thickness of the media.

Mode 2 : Overcuts the start and end points only. In addition, the cutter blade is rotated on the medium surface for the start cutting position only. Mode 2 uses simpler cutter control than Mode 1, and provides a shorter cutting time.

The length of the overcuts by tangential mode can be set individually for start of the line and for end of the line.

Setting the Tangential Mode

On/off and the mode of the tangential mode can be set individually for each of 2-8 tool control numbers.

Operation

- 1 Press the [COND/TEST] key.
▶ CONDITION setting screen (1/3) is displayed.

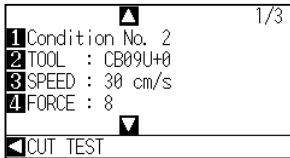

- 2 Press the POSITION (▲) key.
▶ CONDITION setting screen (2/3) is displayed.

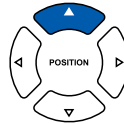
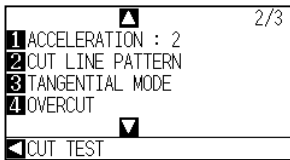

- 3 Press the [3] key (TANGENTIAL MODE).
▶ TANGENTIAL MODE setting screen is displayed.

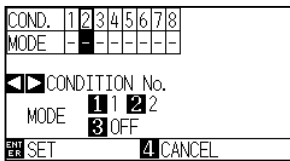

- 4 Press the POSITION (◀▶) keys and select the tool condition number (CONDITION No.).

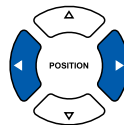

- 5 Press the [1] key (MODE1), the [2] key (MODE2), or the [3] key (OFF) and select the mode.

- 6 Confirm the setting and press the [ENTER] key (SET).
▶ Setting will be set, and it will return to CONDITION setting screen (2/3).

- 7 Press the [COND/TEST] key.
▶ It will return to default screen.

Supplement

Condition No.1 is pen specific. When setting up tool conditions for the cutter plunger, please choose from Condition No.2 to Condition No.8 under "Selecting the Tool Condition". For more information, see "2.10 Selecting Tool Condition" [▶ P.2-29](#).

Supplement

It will return to CONDITION screen (2/3) without changing the settings when you press the [4] key (CANCEL).

Setting Length of the Overcut

Set the length of overcut with tangential mode.

Operation

1 Press the [COND/TEST] key.

▶ CONDITION setting screen (1/3) is displayed.

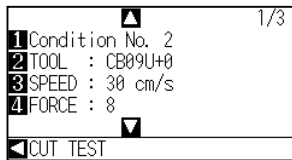

2 Press the POSITION (▲) key.

▶ CONDITION setting screen (2/3) is displayed.

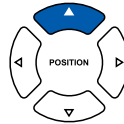
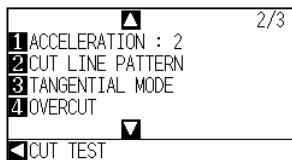

3 Press the [4] key (OVERCUT).

▶ OVERCUT setting screen is displayed.

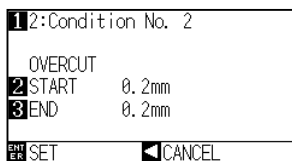

4 Press the [1] key (Condition No.)

▶ CONDITION No. selection screen is displayed.

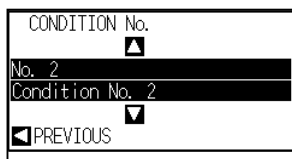

5 Press the POSITION (▲▼) key and select the CONDITION No.

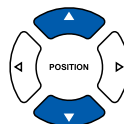

6 Confirm the setting, and press the POSITION (◀) key (PREVIOUS).

▶ Condition No. is selected and return to OVERCUT setting screen.

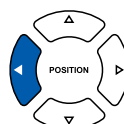

Supplement

Condition No.1 is pen specific. When setting up tool conditions for the cutter plunger, please choose from Condition No.2 to Condition No.8 under "Selecting the Tool Condition". For more information, see "2.10 Selecting Tool Condition" [▶ P.2-29](#).

7 Press the [2] key (START).

▶ Overcut length for START setting screen is displayed.

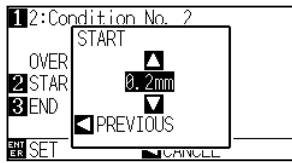

8 Press the POSITION (▲▼) key and increase or decrease the setting value.

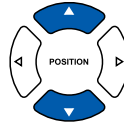

Supplement

Setting range is from 0.0 mm to 0.9 mm.

9 Confirm the setting value, and press the POSITION (◀) key (PREVIOUS).

▶ Length for overcut START is selected and return to OVERCUT setting screen.

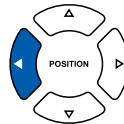

10 Press the [3] key (END).

▶ Overcut length for END setting screen is displayed.

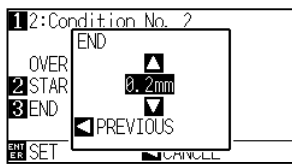

11 Press the POSITION (▲▼) key and increase or decrease the setting value.

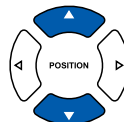

Supplement

Setting range is from 0.0 mm to 0.9 mm.

12 Confirm the setting value, and press the POSITION (◀) key (PREVIOUS).

▶ Length for overcut END is selected and return to OVERCUT setting screen.

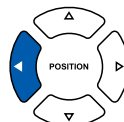

13 Repeat steps 3 to 12 as necessary to set multiple tool CONDITION No.

14 Confirm the setting and press the [ENTER] key (SET).

▶ Setting will be set, and it will return to CONDITION setting screen (2/3).

15 Press the [COND/TEST] key.

▶ It will return to default screen.

Supplement

It will return to CONDITION screen (2/3) without changing the settings when you press the POSITION (◀) key (CANCEL).

Setting of the Initial Down Force

The initial down-force setting is effective when tangential mode is selected.

tangential mode is generally used for the cutting of thick media. With thick film, additional time is required for the cutter blade to penetrate the media fully, even when the necessary cutting force is applied.

The cutting operation starts before the cutter blade has fully penetrated the media, causing uncut sections to be left. When the initial down force is specified, this force is used as the cutting force immediately after the lowering of the tool when tangential mode is selected, enabling the cutter blade to penetrate the media rapidly. (As an example, if the cutting force is 25 and the initial down force is 4, for example, the cutting force applied immediately after the pen is lowered will be 29)

The upper limit for added value is 39.

Operation

- 1 Press the [COND/TEST] key.
▶ CONDITION setting screen (1/3) is displayed.

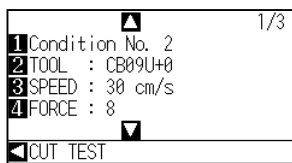

- 2 Press the POSITION (▼) key.
▶ CONDITION setting screen (3/3) is displayed.

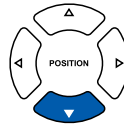
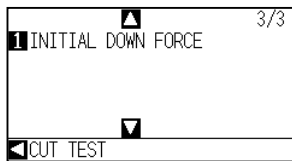

- 3 Press the [2] key (INITIAL DOWN FORCE).
▶ INITIAL DOWN FORCE setting screen is displayed.

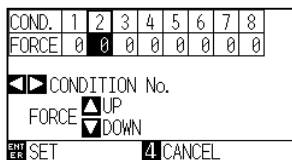

- 4 Press the POSITION (◀▶) key and select the CONDITION No.

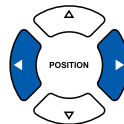

- 5 Press the POSITION (▲▼) key and increase or decrease the setting value.

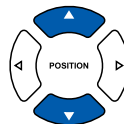

- 6 Confirm the setting and press the [ENTER] key (SET).
▶ Setting will be set, and it will return to CONDITION setting screen (3/3).

- 7 Press the [COND/TEST] key.
▶ It will return to default screen.

Supplement

Condition No.1 is pen specific. When setting up tool conditions for the cutter plunger, please choose from Condition No.2 to Condition No.8 under "Selecting the Tool Condition". For more information, see "2.10 Selecting Tool Condition" → P.2-29.

Supplement

Setting range is from 0 to 20.

Supplement

It will return to CONDITION screen (3/3) without changing the settings when you press the POSITION (◀) key (CANCEL).

6.2

Setting the Step Pass

It may not cut the curved line smoothly if there is very short lines in the curve.

It will cut in the units of the specified value when the STEP PASS is used, which allows to control the short lines with certain length, resulting to stable rotation of the blade for higher cut quality.

Setting range of STEP PASS is from 0 to 20.

Actual length of the STEP PASS is the value of the STEP PASS multiplied by the distance set in the "STEP SIZE".

➡ P.10-4 "Setting the Step Size (STEP SIZE)"

Supplement

- This setting will be saved even if the power is shut off.
- The cut image may not be what you intended if the set value is too large. It is recommended to set to "1" for normal use.

Operation

1 Press the [PAUSE/MENU] key.

▶ MENU screen is displayed.



2 Press the [1] key (TOOL).

▶ TOOLS SETTING screen (1/3) is displayed.

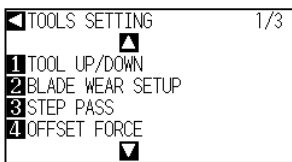

3 Press the [3] key (STEP PASS).

▶ STEP PASS setting screen is displayed.

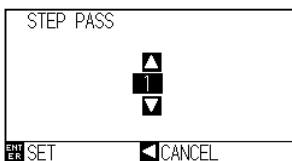

4 Press the POSITION (▲▼) key and increase or decrease the setting value.

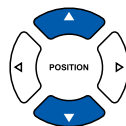

5 Confirm the setting and press the [ENTER] key (SET).

▶ Setting will be set, and it will return to TOOLS setting screen (1/3).

6 Press the [PAUSE/MENU] key.

▶ It will return to default screen.

Supplement

Perform the settings in Normal menu.

Supplement

Setting range is from 0 to 20.

Supplement

It will return to TOOLS SETTING screen (1/3) without changing the settings when you press the POSITION (◀) key (CANCEL).

6.3

Setting the Offset Angle

The CE6000-120AP analyzes the cutting data, and controls the angle of the cutter blade tip if the change in the angles of the corner is large.

Angle control is applied if there is larger angle change than the angle specified as reference angle.

The time to cut is shortened by setting large value for the reference angle, since it will only apply blade control when there are angles with large angle change, hence reducing the time to make the blade control.

But, if it is set too large, there will be not enough angle control of the blade, and the cut result may differ from what was expected. Set the reference angle in good balance.

Supplement

This setting is maintained even if the power is turned off.

Operation

1 Press the [PAUSE/MENU] key.

▶ MENU screen is displayed.



Supplement

Perform the settings in Normal menu.

2 Press the [1] key (TOOL).

▶ TOOLS SETTING screen (1/3) is displayed.

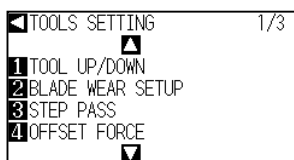

3 Press the POSITION (▲) key.

▶ TOOL SETTING screen (2/3) is displayed.

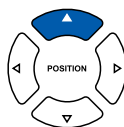
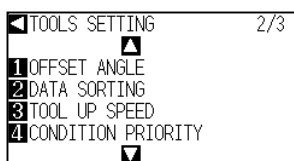

4 Press the [1] key (OFFSET ANGLE).

▶ OFFSET ANGLE screen is displayed.

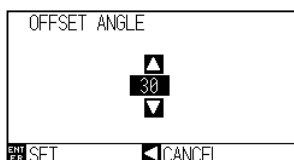

5 Press the POSITION (▲▼) key and increase or decrease the setting value.

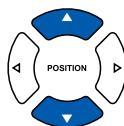

Supplement

Setting range is from 0 to 60.

- 6 Confirm the setting and press the [ENTER] key (SET).
 - ▶ Setting will be set, and it will return to TOOLS SETTING screen (2/3).
- 7 Press the [PAUSE/MENU] key.
 - ▶ It will return to default screen.

Supplement

It will return to TOOLS SETTING screen (2/3) without changing the settings when you press the POSITION (◀) key (CANCEL).

6.4

Setting the Distance Adjust

DISTANCE ADJUST value corrects any deviation in the length of cut or plotted line segments, which occurs depending on the media being used. DISTANCE ADJUST value for the deviation is specified as a percentage of the total distance. For example, a setting of +0.05% adjusts a distance of 2 m (2,000 mm) by $2,000 \times 0.05\% = 1$ mm, making 2,001 mm.

Supplement

This setting will be saved even if the power is shut off.

Operation

1 Press the [COND/TEST] key.

▶ CONDITION setting screen (1/3) is displayed.



2 Press the [3] key (AREA).

▶ AREA PARAMETERS setting screen (1/1) is displayed.

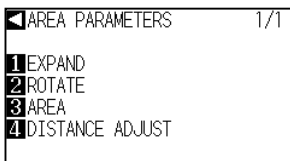

3 Press the [4] key (DISTANCE ADJUST).

▶ DISTANCE ADJUST setting screen is displayed.

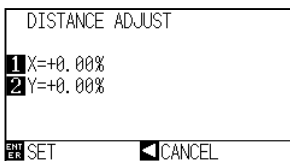

4 Press the [1] key (X).

▶ X DISTANCE ADJUST setting screen is displayed.

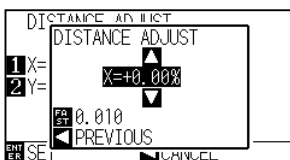

5 Press the POSITION (▲▼) key and increase or decrease the setting value.

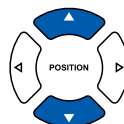

Supplement

Perform the settings in Normal menu.

Supplement

- Setting range for adjustment value is -2.00% to +2.00%.
- Press the [FAST] key to change the setting digits.

6 Confirm the setting value, and press the POSITION (◀) key (PREVIOUS).

▶ X DISTANCE ADJUST will be set, and it will return to DISTANCE ADJUST screen.

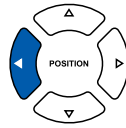

7 Press the [2] key (Y).

▶ Y DISTANCE ADJUST setting screen is displayed.



8 Press the POSITION (▲▼) key and increase or decrease the Y DISTANCE ADJUST value.

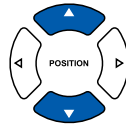

Supplement

- Setting range for adjustment value is -2.00% to +2.00%.
- Press the [FAST] key to change the setting digits.

9 Confirm the setting value, and press the POSITION (◀) key (PREVIOUS).

▶ Y DISTANCE ADJUST will be set, and it will return to DISTANCE ADJUST setting screen.

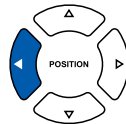

10 Confirm the setting and press the [ENTER] key (SET).

▶ Setting will be set, and it will return to AREA PARAMETERS screen (1/1).

11 Press the [PAUSE/MENU] key.

▶ It will return to default screen.

Supplement

It will return to AREA PARAMETERS screen (1/1) without changing the settings when you press the POSITION (◀) key (CANCEL).

6.5

Setting Initial Blade Control Position Adjust

After turning on the power or changing pen condition settings, touch the blade to the media and adjust the blade direction. The Initial Blade Control Position will need to be set in order to make sure the area is not damaged and that the blade properly makes contact with the media.

Selecting [2mm BELOW] will change the Initial Blade Control Position to 2 mm below the cutting start point (2 mm from the edge of the point from which the media will be shifted.)

Selecting [OUTSIDE] will put the Initial Blade Control Position out of the range of the cutting area.

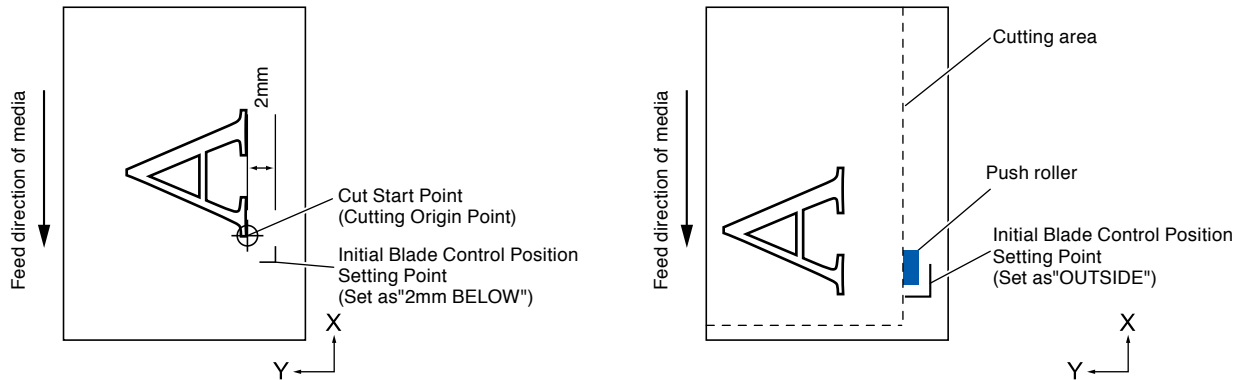

CAUTION

Selecting [OUTSIDE] and then changing the expand setting to a positive digit can damage the marking mat. Also, the Blade Direction Setting may be not properly initialized.

Operation

- 1 Press the [PAUSE/MENU] key.

▶ MENU screen is displayed.



- 2 Press the [1] key (TOOL).

▶ TOOLS SETTING screen (1/3) is displayed.

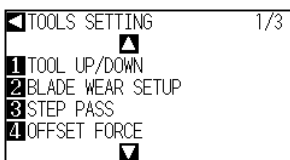

- 3 Press the POSITION (▼) key.

▶ TOOLS SETTING screen (3/3) is displayed.

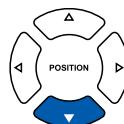
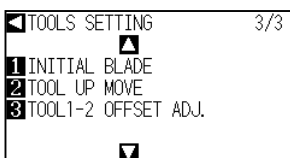

Supplement

Perform the settings in Normal menu.

4 Press the [4] key (INITIAL BLADE).

▶ INITIAL BLADE CONTROL POSITION setting screen is displayed.

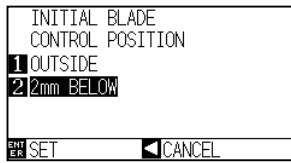

5 Press the [1] key (OUTSIDE) or the [2] key (2mm BELOW).

6 Confirm the setting and press the [ENTER] key (SET).

▶ Setting will be set, and it will return to TOOLS SETTING screen (3/3).

7 Press the [PAUSE/MENU] key.

▶ It will return to default screen.

Supplement

It will return to TOOLS SETTING screen (3/3) without changing the settings when you press the POSITION (◀) key (CANCEL).

6.6

Settings for OFFSET FORCE

Slight cut operation is performed before the actual cut operation to align the blade toward the cutting direction. Lower FORCE is necessary compared with the normal cutting, so it is possible to set lower FORCE as an OFFSET FORCE.

OFFSET FORCE is used to control the rotation of the blade with the tangential mode in addition to control the blade direction at the beginning of the cut.

Operation

1 Press the [PAUSE/MENU] key.

▶ TOOL setting screen (1/3) is displayed.



2 Press the [1] key (TOOL).

▶ TOOLS SETTING screen (1/3) is displayed.

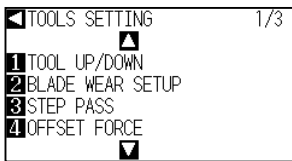

3 Press the [4] key (OFFSET FORCE).

▶ OFFSET FORCE setting screen is displayed.

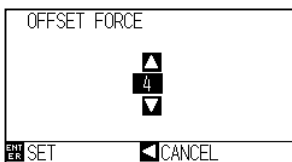

4 Press the POSITION (▲▼) key and increase or decrease the setting value.

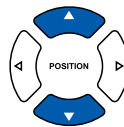

5 Confirm the setting and press the [ENTER] key (SET).

▶ Setting will be set, and it will return to TOOLS SETTING screen (1/3).

6 Press the [PAUSE/MENU] key.

▶ It will return to default screen.

Supplement

Perform the settings in Normal menu.

Supplement

Can be set from 1 to 38.

Supplement

It will return to TOOLS SETTING screen (1/3) without changing the settings when you press the POSITION (◀) key (CANCEL).

6.7

Blade Wear Detection

This function measures the depth of cuts made by the plotter to determine when the cutter blade should be replaced.

Please utilize this function to know when to change blades as cutter-blade wear rate may differ depending on the type of pen (fine ball point versus felt-tip), pen performance (plotting distance) type of material being cut, and the Tool Conditions (amount of cutting force, etc).

The Condition No.'s. are divided into a maximum of 9 available groups and each group calculates the estimated distance individually to determine the blade length. Condition No.1 for plotting pens is fixed as group 1; however, Conditions 0, and 2-8 and associated groups can be altered. Please note that estimated distance cannot be calculated in group 0.

If multiple conditions are put into a single group, the estimated distance will be calculated as the total for each condition.

Furthermore, the weighted coefficient applied to each condition can be changed to adapt to the different wear rates associated with the type of media and the condition settings used. For example, if conditions 2, 3, and 4 were under a single group, each condition would calculate an estimated distance for A, B, or C. Then, you can assign each a coefficient, for example, 0.7, 1.2, and 1.0, making the estimated distance of this group the value of $A \times 0.7 + B \times 1.2 + C \times 1.0$.

Figures' giving a total length of cuts for each group of below 1m will not be incorporated after the machine is turned off.

The blade wear detection is enabled when Blade Wear Setup is ON.

Checking the Wear Rate

When this display is on, you can confirm the present blade wear.

Operation

- 1 Press the [FAST] key in READY status.

▶ This will display blade wear under the Condition No. menu.

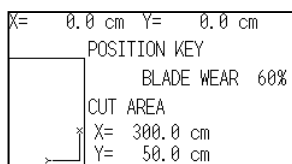

When the blade wear exceeds 100%, the display will show "Please change blade in READY status"

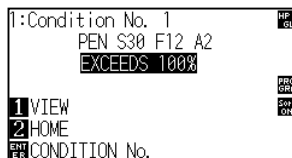

BLADE WEAR DETECT

This setting will detect the blade wear when Blade Wear Setup is ON and will not do so when OFF.

Operation

- 1 Press the [PAUSE/MENU] key.

▶ MENU screen is displayed.



- 2 Press [1] key (TOOL).

▶ TOOL SETTING screen (1/3) is displayed.

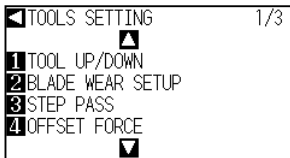

- 3 Press [2] key (BLADE WEAR SETUP).

▶ BLADE WEAR SETUP screen is displayed.

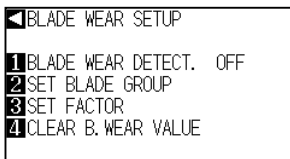

- 4 Press [1] key (BLADE WEAR DETECT.).

▶ BLADE WEAR DETECT screen is displayed.

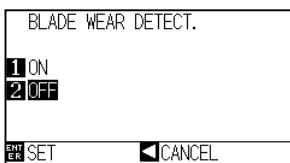

- 5 Press the [1] key (ON) or the [2] key (OFF).

- 6 Confirm the setting and press the [ENTER] key (SET).

▶ Setting will be set, and it will return to BLADE WEAR SETUP screen.

- 7 Press the [PAUSE/MENU] key.

▶ It will return to default screen.

Supplement

Perform the settings in Normal menu.

Supplement

Press [2] key to clear the blade wear.

Supplement

It will return to BLADE WEAR SETUP screen without changing the settings when you press the POSITION (◀) key (CANCEL).

SET BLADE GROUP (blade wear group settings)

These will be recorded under the Condition No. group.

Operation

1 Press the [PAUSE/MENU] key.

▶ MENU screen is displayed.



2 Press [1] key (TOOL).

▶ TOOL SETTING screen (1/3) is displayed.

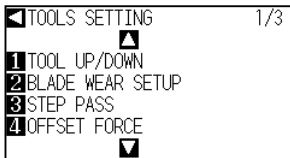

3 Press [2] key (BLADE WEAR SETUP).

▶ BLADE WEAR SETUP screen is displayed.

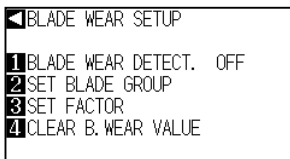

4 Press [2] key (SET BLADE GROUP).

▶ The Blade Group settings screen is displayed.

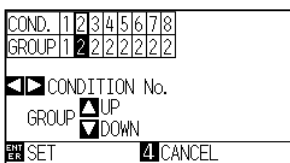

* Display may vary depending on the selected tool condition number.

5 Press the POSITION (◀▶)keys to select the tool condition number (CONDITION No.).

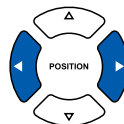

6 Press the POSITION (▲▼) key and increase or decrease the setting value.

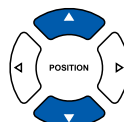

Supplement

Perform the settings in Normal menu.

Supplement

The Condition No.'s. are divided into a maximum of 9 available groups. Condition No.1 for plotting pens and is fixed as group 1; however, Conditions 0, and 2-8 and associated groups can be altered. Please note that estimated distance cannot be calculated in group 0.

- 7 Confirm the setting and press the [ENTER] key (SET).
 - ▶ Setting will be set, and it will return to BLADE WEAR SETUP screen.
- 8 Press the [PAUSE/MENU] key.
 - ▶ It will return to default screen.

Supplement

Press [4] key (CANCEL) to return to the BLADE WEAR SETUP screen without changing any settings.

BLADE WEAR SETUP (Blade wear factor settings)

This setting allows for the adaptation of different wear rates depending on the type of media and the condition settings used.

For the plotting pen, modify depending on the plotting distance.

The setting is based on the plotting distance (1 km) of oil-based ballpoint pen.

Pen type	Plotting distance	Coefficient
Oil-based ballpoint pen	1000 m	1.0
Water-based fiber-tip pen	500 m	2.0

As shown above, the plotting distance of the water-based fiber-tip pen is half of the oil-based ballpoint pen, so please use 2.0 as a reference for the coefficient.

Also, in case of the cutter plunger, it may change depending on the materials and the cutting force conditions.

The reference value is 4 km.

Blade type	Force	Material	Coefficient
CB09U	8	Coated (glossy) paper 80 g/m ²	1.0
CB15U	8	Coated (glossy) paper 80 g/m ²	1.0

Set the coefficient to a high value when the work load is likely to cause significant wear (this shortens the maximum cutting distance).

Set the coefficient to a low value when the work load isn't likely to cause significant wear (this lengthens the maximum cutting distance).

Operation

- 1 Press the [PAUSE/MENU] key.
 - ▶ MENU screen is displayed.



Supplement

Perform the settings in Normal menu.

- 2 Press [1] key (TOOL).
 - ▶ TOOL SETTING screen (1/3) is displayed.

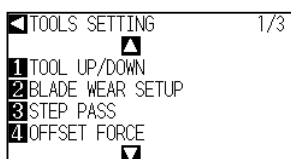

3 Press [2] key (BLADE WEAR SETUP).

▶ BLADE WEAR SETUP screen is displayed.

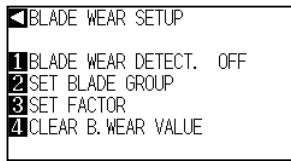

4 Press [3] key (SET FACTOR).

▶ The FACTOR setting screen is displayed.

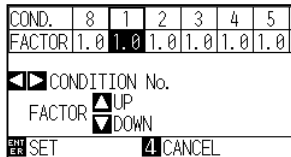

* Display may vary depending on the selected tool condition number.

5 Press the POSITION (◀▶) keys to select the tool condition number (CONDITION No.).

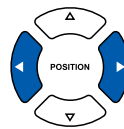

6 Press the POSITION (▲▼) key and increase or decrease the setting value.

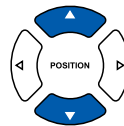

7 Confirm the setting and press the [ENTER] key (SET).

▶ Setting will be set, and it will return to BLADE WEAR SETUP screen.

8 Press the [PAUSE/MENU] key.

▶ It will return to default screen.

Supplement

Press [4] key (CANCEL) to return to the BLADE WEAR SETUP screen without changing any settings.

Supplement

You can set the range between 0.1 and 3.0.

Supplement

It will return to BLADE WEAR SETUP screen without changing the settings when you press the POSITION (◀) key (CANCEL).

CLEAR B. WEAR VALUE (estimated distance method)

Make certain to always clear the estimated distance (return to 0) when changing cutter blades. The new estimated distance will then be recalculated to the new blade.

Operation

- 1 Press the [PAUSE/MENU] key.

▶ MENU screen is displayed.



- 2 Press [1] key (TOOL).

▶ TOOL SETTING screen (1/3) is displayed.

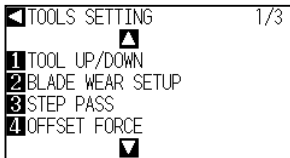

- 3 Press [2] key (BLADE WEAR SETUP).

▶ BLADE WEAR SETUP screen is displayed.

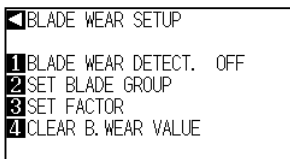

- 4 Press [4] key (CLEAR B. WEAR VALUE).

▶ CLEAR B. WEAR VALUE screen is displayed.

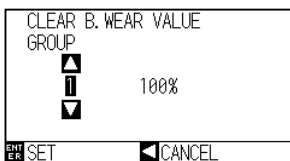

- 5 Press the POSITION (▲▼) keys to select the group.

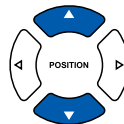

- 6 Confirm the group you want to clear and press [ENTER] key (SET).

▶ Clear confirmation screen is displayed.

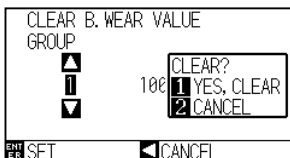

Supplement

Perform the settings in Normal menu.

Supplement

It will return to BLADE WEAR SETUP screen without changing the settings when you press the POSITION (◀) key (CANCEL).

- 7** When clearing it, select [1] key (YES. CLEAR).
When not clearing it, select [2] key (CANCEL).

▶ CLEAR B. WEAR VALUE screen is displayed.

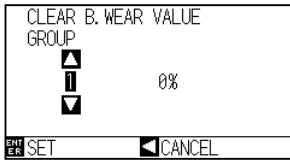

- 8** Confirm the settings and press the [◀] key (CANCEL).

▶ It will return to BLADE WEAR SETUP screen.

- 9** Press the [PAUSE/MENU] key.

▶ It will return to default screen.

6.8

Adjust the space between tools 1 and 2

Adjusting the space between tools 1 and 2 allows you to adjust the alignment of the pen and cutter plungers. First draw a crosshair (the reference line) with the pen set in the pen station/pen holder, then cut the crosshair with the cutter plunger set in the cutter holder. Perform the adjustment by inputting the gap value.

Operation

- 1 Set media that is larger than A1 size.
- 2 Put the cutter plunger in the tool holder and the pen plunger in the pen holder.
Set the tool requirements according to the tools used.

Supplement

See "Loading Media (Paper)" on [P.2-7](#) for how to set supplemental media..

- 2 Put the cutter plunger in the tool holder and the pen plunger in the pen holder.
Set the tool requirements according to the tools used.

Supplement

- The pen plunger is used for Condition No.1, and the cutter plunger is used for Condition No.2.
- For setting the pen plunger, see "Attaching a Tool" [P.2-4](#).
- For changing the tool conditions, see "Selecting Tool Condition" [P.2-29](#), and for tool settings, see "Setting the Tool Condition" [P.2-30](#).

- 3 Press the [PAUSE/MENU] key.

▶ MENU screen is displayed.



Supplement

Perform the settings in Normal menu.

- 4 Press the [1] key (TOOL).

▶ TOOLS SETTING screen (1/3) is displayed.

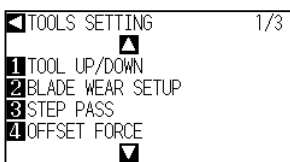

- 5 Press POSITION (▼) key.

▶ TOOL SETTING screen (3/3) is displayed.

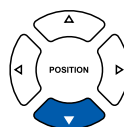
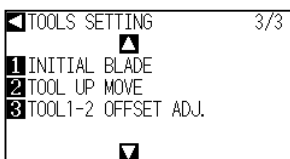

6 Press [3] key (TOOL1-2 OFFSET ADJ.).

▶ TOOL 1-2 OFFSET ADJ. setting screen is displayed.

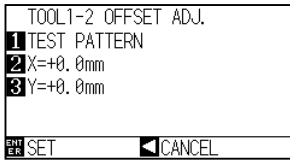

7 Press [1] key (TEST PATTERN).

▶ The following message is displayed.

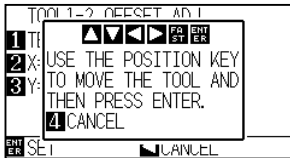

8 Press the POSITION (▲▼◀▶) keys to move the tool carriages to the position to cut a test pattern. Be sure to move it inside of a plotting range greater than 50 mm on both the X and Y axes.

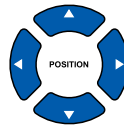

Supplement

- Press (◀) key (CANCEL) to return to Adjust the space between tools 1 and 2 setting screen without changing any settings.
- Press the [FAST] key and the POSITION key simultaneously to move the tool carriage quickly.

9 Confirm the position of tool, and then press [ENTER] key.

▶ Plot a "+" sign with the pen plunger (tool 1).
Next, plot a "+" sign with the cutter plunger (tool 2).
The settings screen for adjusting the space between tools 1 and 2 will be displayed after the plotting is completed.

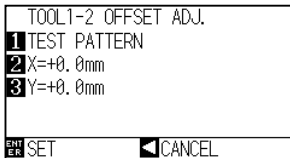

10 Measure how much the "+" cut with the cutter plunger (Tool 2) is out of alignment with the reference "+" plotted with the pen plunger (Tool 1). (For example, in the following figure, input $X = +a$ mm and $Y = -b$ mm, since it's out of alignment in the negative X-axis and the positive Y-axis)

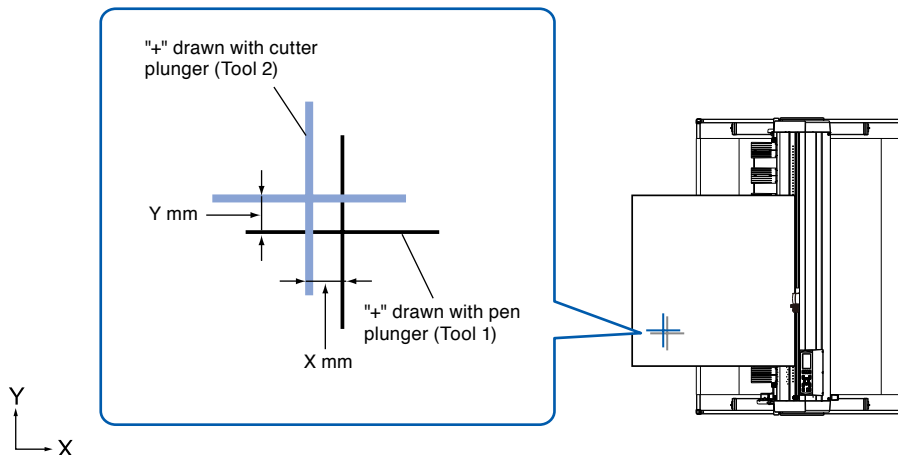

11 Press [2] key (X=+0.0mm).

▶ Adjust the space between tools 1 and 2 (X) setting screen is displayed.

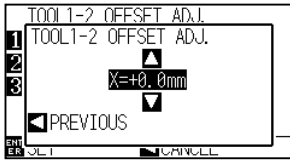

12 Press POSITION (▲▼) keys to increase or decrease the parameters.

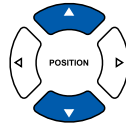

Supplement

You can set between -3.0mm and +3.0mm.

13 Confirm the settings and press the POSITION (◀) key (PREVIOUS).

▶ Adjust the space between tools 1 and 2 (X) setting screen is displayed.

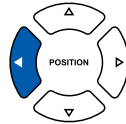

14 Press [3] key (Y=+0.0mm).

▶ Adjust the space between tools 1 and 2 (Y) setting screen is displayed.



15 Press POSITION (▲▼) keys to increase or decrease the parameters.

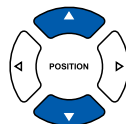

Supplement

You can set between -3.0mm and +3.0mm.

16 Confirm the settings and press the POSITION (◀) key (PREVIOUS).

▶ Adjust the space between tools 1 and 2 (Y) setting screen is displayed.

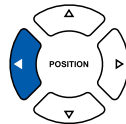

17 Repeat steps 7 through 16 until there is no longer a gap between the two tools.

18 Confirm the space and press the [ENTER] key (SET).

▶ Setting will be set, and it will return to TOOL SETTING screen (3/3).

19 Press the [PAUSE/MENU] key.

▶ It will return to default screen.

Supplement

It will return to TOOLS SETTING screen (3/3) without changing the settings when you press the POSITION (◀) key (CANCEL).

Chapter 7:

Settings Regarding Cutting Time

Time necessary for cutting depends on the speed to move the tool and media, and efficiency of the operation. It is best to cut slowly and carefully to cut precisely, but the speed is required to enhance the operational efficiency. The setting needs to be in good balance considering the characteristics of the media and tools, and the contents of the cutting data.

This chapter describes the settings affecting the cutting time.

In addition to this chapter, there are setting affecting the cutting times in following places.

➡ **P.2-30** Setting the Tool Condition

PRODUCT SUMMARY

- 7.1 *Sorting the Cutting Data***
- 7.2 *Perform Automatic Pre Feed When Cut Data is Received***
- 7.3 *Perform Automatic Pre Feed When Media is Set (Initial Feed)***
- 7.4 *Setting Feed Speed for Pre Feed***
- 7.5 *Setting the Tool Up Speed***
- 7.6 *Setting the Tool Up Move***

7.1

Sorting the Cutting Data

Sorting the cutting area parameter data will increase cut efficiency by minimizing time spent by changing tools and by grouping cuttings to happen all at once.

First plot the data from the pen plunger (Condition No.1), then plot (cut) the cutter plunger (Condition No.2 through No.8).

Supplement

- Sorting will start the process after all the data are stored in the buffer memory, so it takes time to start the cutting.
- Sorting might not be effective for the data that is created efficiently.
- Process may be faster to turn off the sorting on the plotter, if the data is already sorted using the software on the PC.

Operation

1 Press the [PAUSE/MENU] key.

▶ MENU screen is displayed.



Supplement

Perform the settings in Normal menu.

2 Press the [1] key (TOOL).

▶ TOOLS SETTING screen (1/3) is displayed.

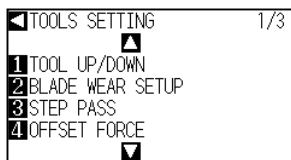

3 Press the POSITION (▲) key.

▶ TOOLS SETTING screen (2/3) is displayed.

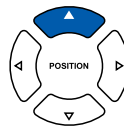
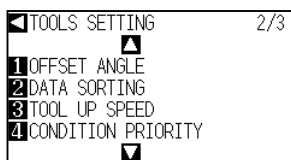

4 Press the [2] key (DATA SORTING).

▶ DATA SORTING setting screen is displayed.



5 Press the [1] key (ON) or the [2] key (OFF).

6 Confirm the setting and press the [ENTER] key (SET).

▶ Setting will be set, and it will return to TOOLS SETTING screen (2/3).

7 Press the [PAUSE/MENU] key.

▶ It will return to default screen.

Supplement

It will return to TOOLS setting screen (2/3) without changing the settings when you press the POSITION (◀) key (CANCEL).

Supplement

[] mark is displayed at the right of the screen when SORT MODE is set. See "How to Use Control Panel" [▶ P.2-21](#) .

7.2

Perform Automatic Pre Feed When Cut Data is Received

It is possible to feed and reverse the media automatically for specified amount when the plotter receives the cutting data.

"Pre feeding" to prevent the shifting of media can be done automatically. Also, the media will be unrolled from the roll before cutting when rolled media is to be used.

➡ P.7-6 "Perform Automatic Pre Feed When Media is Set (Initial Feed)"

➡ P.7-8 "Setting Feed Speed for Pre Feed"

Supplement

- The setting for AUTO PRE FEED when cutting data is received is maintained even if the power is turned off.
- Setting of the AUTO PRE FEED length is not linked to the setting of the page length. Change the setting for the page length if the cutting area is to be long.
- If data is received and auto media transfer is performed once, even if (cut in the same area) data is received again, auto media transfer will not take place.

Operation

1 Press the [PAUSE/MENU] key.

▶ MENU screen is displayed.



Supplement

Perform the settings in Normal menu.

2 Press the [4] key (MEDIA).

▶ MEDIA SETTING screen (1/3) is displayed.

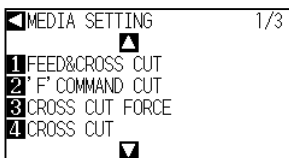

3 Press the POSITION (▲) key.

▶ MEDIA SETTING screen (2/3) is displayed.

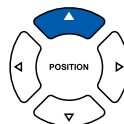
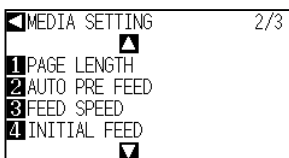

4 Press the [2] key (AUTO PRE FEED).

▶ AUTO PRE FEED screen is displayed.

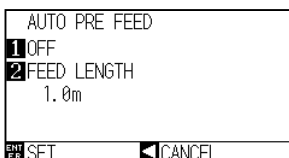

5 Press the [1] key (OFF).

▶ AUTO PRE FEED setting screen is displayed.

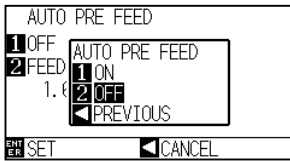

6 Press the [1] key (ON) or the [2] key (OFF).

▶ AUTO PRE FEED is selected and return to AUTO PRE FEED screen.

Supplement
It will return to MEDIA SETTING screen (2/3) without changing the settings when you press the POSITION (◀) key (PREVIOUS).

7 Press the [2] key (FEED LENGTH).

▶ FEED LENGTH setting screen is displayed.

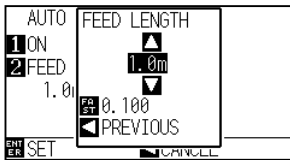

8 Press the POSITION (▲▼) key and increase or decrease the setting value.

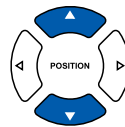

Supplement
• Feed length can be set in 0.1 m units.
• Setting range is 0.5 m to 50.0 m.
• Press the FAST key to change the setting digits.

9 Confirm the setting value, and press the POSITION (◀) key (CANCEL).

▶ FEED LENGTH is selected and return to AUTO PRE FEED screen.

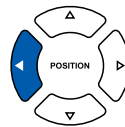

Supplement
It will return to MEDIA SETTING screen (2/3) without changing the settings when you press the POSITION (◀) key (CANCEL).

10 Confirm the setting and press the [ENTER] key.

▶ Setting will be set, and it will return to MEDIA SETTING screen (2/3).

Supplement
When setting the auto media feed, the [PreFEED] sign will appear on the right side of the screen. See "How to Use Control Panel" P.2-21.

11 Press the [PAUSE/MENU] key.

▶ It will return to default screen.

7.3

Perform Automatic Pre Feed When Media is Set (Initial Feed)

It can be set to automatically feed and return the length of the page when the media is loaded and the media set lever is raised.

This is equal to automatically perform the "Pre Feed" to prevent the shifting of the media.

- ➡ P.4-7 "Setting the number of pre feeds"
- ➡ P.4-8 "Setting paper Ready time"
- ➡ P.7-4 "Perform Automatic Pre Feed When Cut Data is Received"
- ➡ P.7-8 "Setting Feed Speed for Media Set"

Supplement

This setting will be saved even if the power is shut off.

Operation

1 Press the [PAUSE/MENU] key.

▶ MENU screen is displayed.



Supplement

Perform the settings in Normal menu.

2 Press the [4] key (MEDIA).

▶ MEDIA SETTING screen (1/3) is displayed.

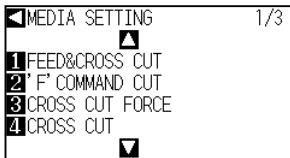

3 Press the POSITION (▲) key.

▶ MEDIA SETTING screen (2/3) is displayed.

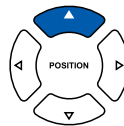
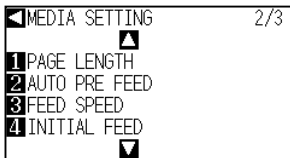

4 Press the [4] key (INITIAL FEED).

▶ INITIAL FEED screen is displayed.

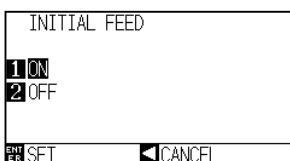

5 Set the mode by pressing the [1] key (ON) or the [2] key (OFF).

- 6** Confirm the setting and press the [ENTER] key (SET).
- ▶ Setting will be set, and it will return to MEDIA SETTING screen (2/3).

- 7** Press the [PAUSE/MENU] key.
- ▶ It will return to default screen.

Supplement

It will return to MEDIA SETTING screen (2/3) without changing the settings when you press the POSITION (◀) key.

7.4

Setting Feed Speed for Pre Feed

Sets the speed of media transfer during the feed (media carry) of auto media transfer of received cut data, leveling of the initial feed etc.

Set the feed speed to "SLOW" when using media that is thin and folds easily. Under regular circumstances, it should be set to "NORMAL".

➔ P.4-7 "Setting the number of pre feeds"

➔ P.7-6 "Perform Automatic Pre Feed When Media is Set (Initial Feed)"

➔ P.7-4 "Perform Automatic Pre Feed When Cut Data is Received"

Supplement

This setting will be saved even if the power is shut off.

Operation

1 Press the [PAUSE/MENU] key.

▶ MENU screen is displayed.



2 Press the [4] key (MEDIA).

▶ MEDIA SETTING screen (1/3) is displayed.

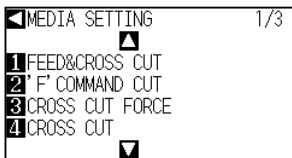

3 Press the POSITION (▲) key.

▶ MEDIA SETTING screen (2/3) is displayed.

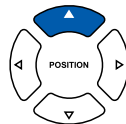
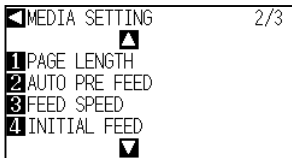

4 Press the [3] key (FEED SPEED).

▶ FEED SPEED setting screen is displayed.

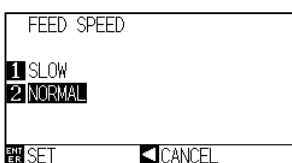

5 Press the [1] key (SLOW) or the [2] key (NORMAL).

Supplement

Perform the settings in Normal menu.

- 6** Confirm the setting and press the [ENTER] key (SET).
- ▶ Setting will be set, and it will return to MEDIA SETTING screen (2/3).

- 7** Press the [PAUSE/MENU] key.
- ▶ It will return to default screen.

Supplement

It will return to MEDIA SETTING screen (2/3) without changing the settings when you press the POSITION (◀) key (CANCEL).

7.5

Setting the Tool Up Speed

TOOL UP SPEED is the speed the tool moves when it is raised.

The cutting time in total becomes short if you set the TOOL UP SPEED to fast speed even though the speed of the tool when it is cutting (lowered) is set to slow speed for the hard to cut media (hard or sticky).

Supplement

This setting will be saved even if the power is shut off.

Operation

1 Press the [PAUSE/MENU] key.

▶ MENU screen is displayed.



Supplement

Perform the settings in Normal menu.

2 Press the [1] key (TOOL).

▶ TOOLS SETTING screen (1/3) is displayed.

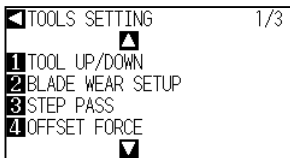

3 Press the POSITION (▲) key.

▶ TOOLS SETTING screen (2/3) is displayed.

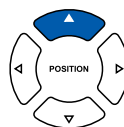
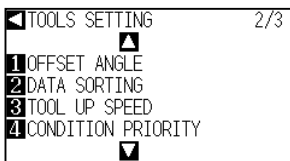

4 Press the [3] key (TOOL UP SPEED).

▶ TOOL UP SPEED setting screen is displayed.

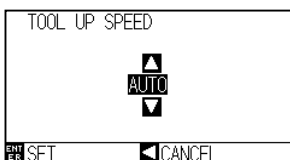

5 Press the POSITION (▲▼) key and increase or decrease the setting value.

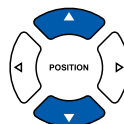

Supplement

- Values that can be set are AUTO, 10, 20, 30, 40, 50, and 60.
- It will be same speed as tool is lowered when AUTO is selected.

- 6** Confirm the setting and press the [ENTER] key (SET).
- ▶ Setting will be set, and it will return to TOOLS SETTING screen (2/3).

- 7** Press the [PAUSE/MENU] key.
- ▶ It will return to default screen.

Supplement

It will return to TOOLS SETTING screen (2/3) without changing the settings when you press the POSITION (◀) key (CANCEL).

7.6

Setting the Tool Up Move

"Tool up movement" is when you continuously receive tool up movement coordinate news from the computer connected to the CE6000-120AP and set whether to move to every coordinate in order or go directly to the last one.

There are following 2 settings for "TOOL UP MOVE".

ENABLED : If several coordinates are received continuously, it will move to each in order it is received.

DISABLED : If several coordinates are received continuously, it will directly move to the last coordinate received.

Cutting time can be reduced if it is set to "DISABLED", if the time to move the tool in raised status is wasteful.

Supplement

This setting will be saved even if the power is shut off.

Operation

1 Press the [PAUSE/MENU] key.

▶ MENU screen is displayed.



Supplement

Perform the settings in Normal menu.

2 Press the [1] key (TOOL).

▶ TOOLS SETTING screen (1/3) is displayed.

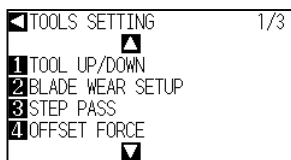

3 Press the POSITION (▼) key.

▶ TOOLS SETTING screen (3/3) is displayed.

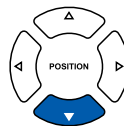
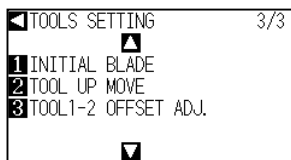

4 Press the [2] key (TOOL UP MOVE).

▶ TOOL UP MOVE setting screen is displayed.

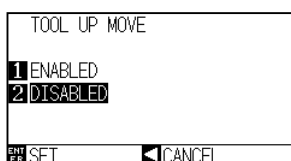

5 Press the [1] key (ENABLED) or the [2] key (DISABLED).

- 6** Confirm the setting and press the [ENTER] key (SET).
- ▶ Setting will be set, and it will return to TOOLS SETTING screen (3/3).

- 7** Press the [PAUSE/MENU] key.
- ▶ It will return to default screen.

Supplement

It will return to TOOLS SETTING screen (3/3) without changing the settings when you press the POSITION (◀) key (CANCEL).

Chapter 8: Setting Regarding Interface

This chapter describes setting regarding interface.

PRODUCT SUMMARY

- 8.1 Setting Interface***
- 8.2 Setting a separator***
- 8.3 Setting a timeout***

8.1

Setting Interface

This section describes how to set the interface.

The plotter has USB and RS-232C interfaces, and these interfaces are switched automatically.

USB Interface

To use the USB interface, a driver software must be installed in the computer. Please the SETUP MANUAL to install the driver software.

Please the Setup Manual to install the plotter driver.

For the plotter side, please perform command settings*, step size settings (when using GP-GL commands), and origin point settings for HP-GL (when using HP-GL commands).

* They cannot be set in Simple menu. Set them in Normal menu.

CAUTION

Operation cannot be guaranteed in the following cases:

- When the plotter is connected to a USB hub or extension port.
- When the plotter is connected to a hand-built or modified computer.
- When a driver software other than the one provided as a standard accessory is used.

Do not perform the followings:

- Do not connect or disconnect the USB cable while installing the USB driver software on the computer.
- Do not connect or disconnect the USB cable when the computer or the plotter is performing an initialization routine.
- Do not disconnect the USB cable within a 5-second period of connecting it.
- Do not connect multiple plotters to a single computer using the USB interface.

RS-232C Interface

When using the RS-232C interface, set the command settings, step size settings (when using GP-GL commands), origin point settings for HP-GL (when using HP-GL commands), and transfer conditions for the RS-232C interface. The transfer conditions for the RS-232C interface can be set from the operations panel. The transfer condition should be set to the same in the software used and in the CE6000-120AP. If there is a mistake in the settings an error may displayed in the machine and lack of data can cause a malfunction. In such a case, please confirm the data transfer settings again.

- ➡ P.3-9 Setting Origin Point When HP-GL is set
- ➡ P.8-3 Connecting with RS-232C
- ➡ P.10-2 Setting the Command (COMMAND)
- ➡ P.10-4 Setting the Step Size (GP-GL STEP SIZE)

Interface Setting Menu

Setting of the interface condition is only necessary when the plotter is connected using RS- 232C cables. It is not necessary when the plotter is connected using the USB cable.

- ➡ P.8-3 Connecting with RS-232C

Connecting with RS-232C

The RS-232C settings can remember up to 8 different settings that can be switched if necessary. Call up the setting to be used according to "Switching the user selection setting" [P.8-4](#), and then change and save the RS-232C settings according to "Changing and saving the RS-232C interface setting" [P.8-5](#)."

Setting user selection

Call up the user selection settings (CAD). "Command", "Origin point", "Step size", "Separator", "Timeout", "Page length", and "Transfer conditions for RS-232C" have been set.

List of user selection settings

User selection settings	1	2	3	4	5	6	7	8
Command	HP-GL	HP-GL	GP-GL	HP-GL	HP-GL	HP-GL	HP-GL	HP-GL
Step size	0.025	0.025	0.025	0.025	0.025	0.025	0.025	0.025
Origin point	LOWER LEFT	CENTER	LOWER LEFT	LOWER LEFT	LOWER LEFT	CENTER	CENTER	CENTER
Separator	PG	NR	J0	SP	PG	SP	None	None
Time out	0	0	120	120	1	10	0	0
Page length (mm)	1500	3000	1500	5000	3000	1500	5000	5000
Transfer conditions	9600N81X	9600N81X	9600N81X	9600N81X	9600N81X	19200N81X	9600N81X	9600N81X
Step pass	–	–	–	–	–	0	–	–
Tool up speed	–	–	–	–	–	60 cm/s	–	–
Cross cut	–	–	–	–	–	ON	–	–
Cut line pattern	–	–	–	–	–	OFF	–	–
Space rear	–	–	–	–	–	12 mm	–	–

–: The current value is set.

User preference 6 is determined as per the following cutter pen conditions (all settings other than those listed revert to default).

The settings other than the table are set to default value.

Condition No.	Speed	Acceleration	Force	Pen type (Cutter blade)	Compensation value (Offset)
1	60	1	17	Pen	–
2	30	1	14	09U	0
3	30	1	14	09U	0
4	30	1	14	09U	0
5	30	1	14	09U	0
6	30	1	14	09U	0
7	30	1	14	09U	0
8	60	1	14	09U	0

Switching the user selection setting

Operation

1 Press [PAUSE/MENU] key in default screen.

▶ MENU screen is displayed.



MENU screen
(Normal menu)

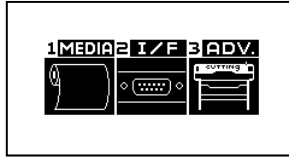

MENU screen
(Simple menu)

2 Press POSITION (▲) key (I/F) in Normal menu, press [2] key (I/F) in Simple menu.

▶ INTERFACE SETTING screen is displayed.

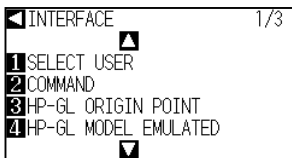

INTERFACE setting screen
(Normal menu)

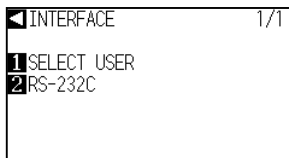

INTERFACE setting screen
(Simple menu)

3 Press the [1] key (SELECT USER).

▶ ELECT USER setting screen is displayed.

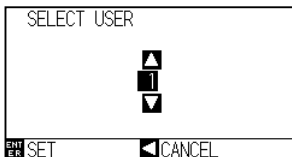

4 Press the POSITION (▲▼) keys to change the current setting.

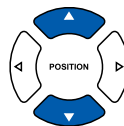

5 Confirm the setting and press the [ENTER] key (SET).

▶ Setting will be set, and the restart is activated.

Supplement

You can select the set number between 1 and 8.

Supplement

It will return to INTERFACE setting screen without changing the settings when you press the POSITION (◀) key (CANCEL).

Changing and saving the RS-232C interface setting

Operation

1 Press [PAUSE/MENU] key in default screen.

▶ MENU screen is displayed.



MENU screen
(Normal menu)

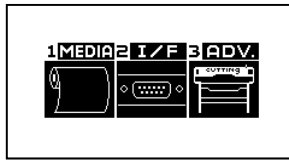

MENU screen
(Simple menu)

2 Press POSITION (▲) key (I/F) in Normal menu, press [2] key (I/F) in Simple menu.

▶ INTERFACE SETTING screen is displayed.

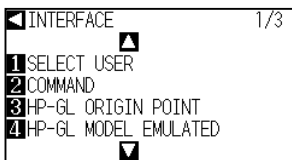

INTERFACE setting screen
(Normal menu)

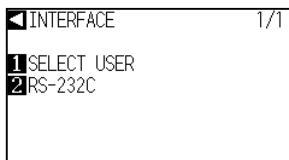

INTERFACE setting screen
(Simple menu)

3 Press POSITION (▲) key (I/F) in Normal menu.

▶ INTERFACE setting screen (2/3) is displayed.

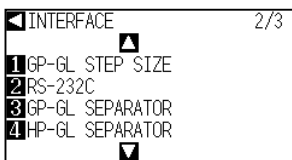
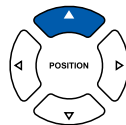

INTERFACE setting screen
(Normal menu)

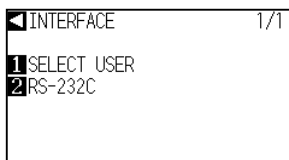

INTERFACE setting screen
(Simple menu)

4 Press the [2] key (RS-232C).

▶ RS-232C setting screen is displayed.



5 Press the [1] key (BAUD RATE).

▶ BAUD RATE setting screen is displayed.

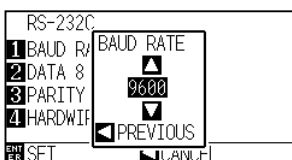

Supplement

Baud rate can be set to 19200, 9600, 4800, 2400, 1200, 600, and 300.

- 6 Press the POSITION (▲▼) key and increase or decrease the setting value.

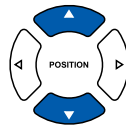

Supplement

Match the setting value of the application to be used.

- 7 Confirm the setting and press the POSITION (◀) key (PREVIOUS).

▶ BAUD RATE will be set, and it will return to RS-232C setting screen.

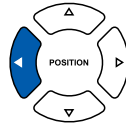

- 8 Press the [2] key (DATA BIT).

▶ DATA BIT setting screen is displayed.

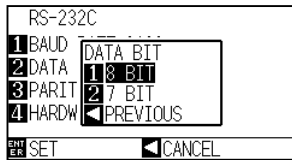

- 9 Press the [1] key (8 BIT) or the [2] key (7 BIT).

▶ DATA BIT will be set, and it will return to RS-232C setting screen.

Supplement

- Match the setting value of the application to be used.
- It will return to RS-232C setting screen without changing the settings when you press POSITION (◀) key (PREVIOUS).

- 10 Press the [3] key (PARITY).

▶ PARITY setting screen is displayed.

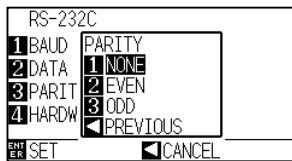

- 11 Press the [1] key (NONE), [2] key (EVEN), or the [3] key (ODD).

▶ PARITY will be set, and it will return to RS-232C setting screen.

Supplement

- Match the setting value of the application to be used.
- It will return to RS-232C setting screen without changing the settings when you press POSITION (◀) key (PREVIOUS).

- 12 Press the [4] key (HANDSHAKE).

▶ HANDSHAKE setting screen is displayed.



13 Press the [1] key (HARDWIRE), the [2] key (Xon/off), or the [3] key (Enq/Ack).

▶ HANDSHAKE will be selected, and it will return to RS-232C setting screen.

14 Confirm the setting and press the [ENTER] key (SET).

▶ Setting will be set, and it will return to INTERFACE setting screen.

15 Press the [PAUSE/MENU] key.

▶ It will return to default screen.

Supplement

- Match the setting value of the application to be used.
- It will return to RS-232C setting screen without changing the settings when you press POSITION (◀) key (PREVIOUS).
- Enq/Ack setting is valid only when it is set to HP-GL. It will be set to HARDWIRE even if Enq/Ack is selected when it is set to GP-GL.

8.2

Setting a separator

Regarding the separator settings, the command that is set as separator is judged as the data juncture when it is sent. All data up to that juncture will be plotted, after which cross cutting will be performed.

GP-GL Separator

Set the separator when using GP-GL.

Reference

This setting will be saved even if the power is shut off.

Operation

1 Press the [PAUSE/MENU] key.

▶ MENU screen is displayed.



2 Press the POSITION (▲) key (I/F).

▶ INTERFACE setting screen (1/3) is displayed.

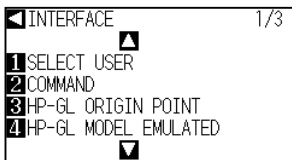

3 Press the POSITION (▲) key.

▶ INTERFACE setting screen (2/3) is displayed.

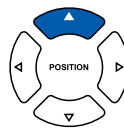
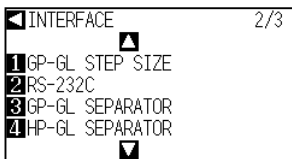

4 Press [3] key (GP-GL SEPARATOR).

▶ GP-GL SEPARATOR screen is displayed.

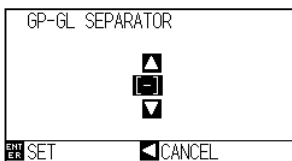

5 Press the POSITION (▲▼) keys to change the current setting.

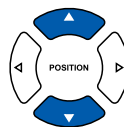

Supplement

Perform the settings in Normal menu.

Supplement

You can set "FS", "H", "J0", "F", or "-".

- 6 Confirm the setting and press the [ENTER] key (SET).
 - ▶ Setting will be set and it will return to INTERFACE setting screen (2/3).
- 7 Press the [PAUSE/MENU] key.
 - ▶ It will return to default screen.

Supplement

It will return to INTERFACE setting (2/3) screen without changing the settings when you press the POSITION (◀) key (CANCEL).

HP-GL Separator

Set the separator when using HP-GL

Reference

This setting will be saved even if the power is shut off.

Operation

- 1 Press the [PAUSE/MENU] key.
 - ▶ MENU screen is displayed.



Supplement

Perform the settings in Normal menu.

- 2 Press the POSITION (▲) key (I/F).
 - ▶ INTERFACE setting screen (1/3) is displayed.

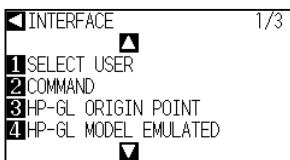

- 3 Press the POSITION (▲) key.
 - ▶ INTERFACE setting screen (2/3) is displayed.

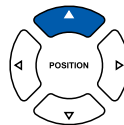
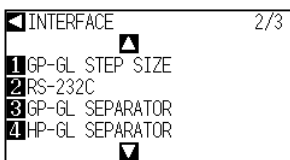

- 4 Press [4] key (HP-GL SEPARATER).
 - ▶ HP-GL SEPARATOR screen is displayed.

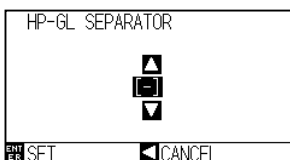

5 Press the POSITION (▲▼) keys to change the current setting.

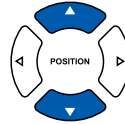

Supplement

You can set "IN", "DF", "PS", "IW", "SC", "IP", "SP", "NR", "PG", "AH", "AF", or "-".

6 Confirm the setting and press the [ENTER] key (SET).

▶ Setting will be set and it will return to INTERFACE setting screen (2/3).

7 Press the [PAUSE/MENU] key.

▶ It will return to default screen.

Supplement

It will return to INTERFACE setting (2/3) screen without changing the settings when you press the POSITION (◀) key (CANCEL).

8.3

Setting a timeout

Regarding the timeout settings, when an interval opens that is longer than the set amount of time, that part will be judged as the data juncture for the data that is entered on the interface. All data up to that juncture will be plotted, after which cross cutting will be performed.

Reference

This setting will be saved even if the power is shut off.

Operation

1 Press the [PAUSE/MENU] key.

▶ MENU screen is displayed.



2 Press the POSITION (▲) key (I/F).

▶ INTERFACE setting screen (1/3) is displayed.

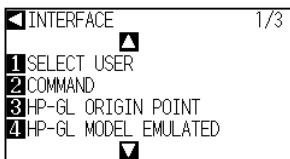

3 Press the POSITION (▼) key.

▶ INTERFACE setting screen (3/3) is displayed.

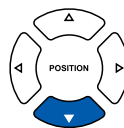
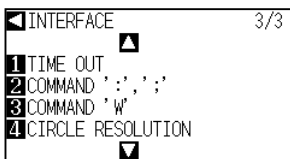

4 Press [1] key (TIME OUT).

▶ TIME OUT screen is displayed.

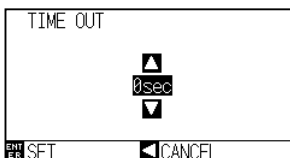

5 Press the POSITION (▲▼) keys to change the current setting.

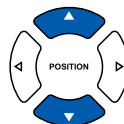

Supplement

Perform the settings in Normal menu.

Supplement

- You can set 0, 1, 2, 3, 5, 10, 20, 30, 60 or 120 (Seconds).
- When setting to 0 seconds, the cut cross with timeout is not enabled.

- 6 Confirm the setting and press the [ENTER] key (SET).
 - ▶ Setting will be set and it will return to INTERFACE setting screen (3/3).
- 7 Press the [PAUSE/MENU] key.
 - ▶ It will return to default screen.

Supplement

It will return to INTERFACE setting (3/3) screen without changing the settings when you press the POSITION (◀) key (CANCEL).

Chapter 9: Settings Regarding Operation Environment

This chapter describes setting regarding the operation environment.

Related to Menu Display

Display Language Setting (LANGUAGE SELECTION)

This function sets the language used on the display.

One of ten languages can be selected: English, Japanese, German, French, Italian, Spanish, Portuguese, Russian, Korean, and Chinese.

Operation

- 1 Press the [PAUSE/MENU] key in the default screen.

▶ MENU screen is displayed.

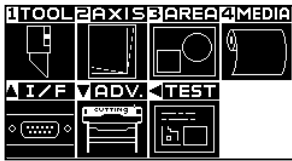

Supplement

Perform the settings in Normal menu.

- 2 Press POSITION (▼) key (ADV.).

▶ ADVANCE setting screen (1/2) is displayed.

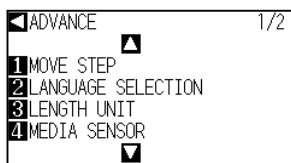

- 3 Press [2] key (LANGUAGE SELECTION).

▶ LANGUAGE SELECTION screen is displayed.

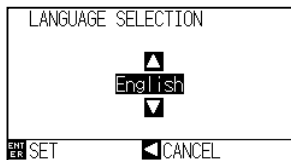

- 4 Press the POSITION (▲▼) key and select the language.
(In these instructions it's explained for when it's set to English.)

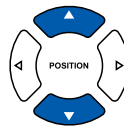

- 5 Confirm the setting and press the [ENTER] key (SET).

▶ Setting will be set, and it will return to ADVANCE setting screen (1/2).

- 6 Press the [PAUSE/MENU] key.

▶ It will return to the default screen.

Display Length Unit Settings (LENGTH UNIT)

The coordinate values that appear on the display and the other parameters for various settings can be changed to either meter or inch display.

Operation

- 1 Press the [PAUSE/MENU] key in the default screen.

▶ MENU screen is displayed.



MENU screen
(Normal menu)

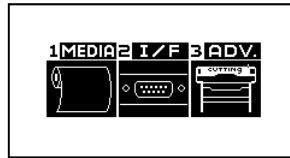

MENU screen
(Simple menu)

- 2 Press the POSITION (▼) key (ADV.) in Normal menu, or press the [3] key (ADV.) in Simple menu.

▶ ADVANCE setting screen is displayed.

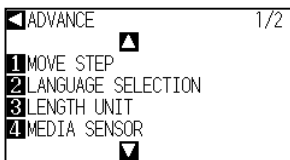

ADVANCE setting screen
(Normal menu)

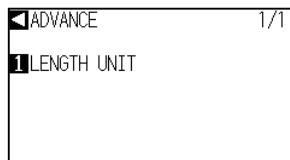

ADVANCE setting screen
(Simple menu)

- 3 Press the [3] key (LENGTH UNIT) in Normal menu, or press the [1] key (LENGTH UNIT) in Simple menu.

▶ LENGTH UNIT setting screen is displayed.

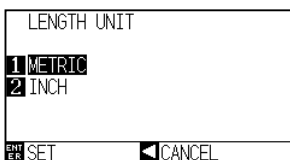

- 4 Press the [1] key (METRIC) or the [2] key (INCH).

- 5 Confirm the setting and press the [ENTER] key (SET).

▶ Setting will be set, and it will return to ADVANCE setting screen.

- 6 Press the [PAUSE/MENU] key.

▶ It will return to the default screen.

Related to Sensor

Enabling/Disabling the Media Sensors (MEDIA SENSOR)

This function enables or disables the media sensors that detect the size of the medium in the feed direction.

CAUTION

Normally, please use it while set to "ON". Turn it OFF when setting undetectable media with high transmittance. When set to "OFF", the marking mat may be damaged. Please be sure to configure the "area".

Operation

- 1 Press the [PAUSE/MENU] key in the default screen.

▶ MENU screen is displayed.

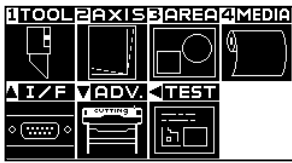

Supplement

Perform the settings in Normal menu.

- 2 Press the POSITION (▼) key (ADV.).

▶ ADVANCE setting screen (1/2) is displayed.

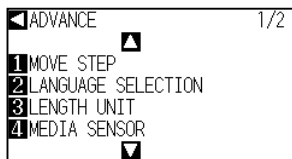

- 3 Press the [4] key (MEDIA SENSOR).

▶ MEDIA SENSOR setting screen is displayed.

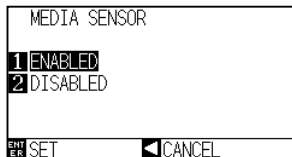

- 4 Press the [1] key (ENABLED) or the [2] key (DISABLED).

- 5 Confirm the setting and press the [ENTER] key (SET).

▶ Setting will be set, and it will return to ADVANCE setting screen (1/2).

- 6 Press the [PAUSE/MENU] key.

▶ It will return to the default screen.

Enabling/Disabling the Push Roller Sensors (PUSH ROLLER SENSOR)

This function enables or disables the push roller sensors that detect the width of the media.

Operation

1 Press the [PAUSE/MENU] key in the default screen.

▶ MENU screen is displayed.



2 Press the POSITION (▼) key (ADV.).

▶ ADVANCE setting screen (1/2) is displayed.

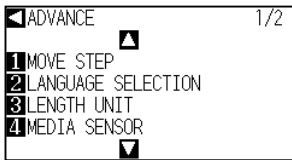

3 Press the POSITION (▲) key.

▶ ADVANCE setting screen (2/2) is displayed.

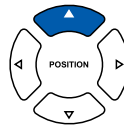
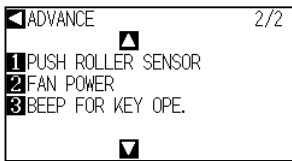

4 Press the [1] key (PUSH ROLLER SENSOR).

▶ PUSH ROLLER SENSOR setting screen is displayed.

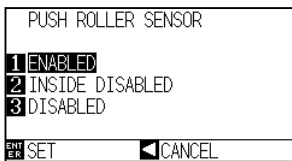

5 Press the [1] key (ENABLED), the [2] key (INSIDE DISABLED), or the [3] key (DISABLED).

6 Confirm the setting and press the [ENTER] key (SET).

▶ Setting will be set, and it will return to ADVANCE setting screen (1/2).

7 Press the [PAUSE/MENU] key.

▶ It will return to the default screen.

Supplement

Perform the settings in Normal menu.

Supplement

If "DISABLED" is selected, push roller detection is not performed.

It will not generate error even if the inner push rollers are not on the grit rollers when the "INSIDE DISABLED" is selected.

Supplement

When "DISABLE" has been set, the home sensor position is not detected, so depending on the data, a position error could occur. Also, an error will occur when going to take the pen plunger from the pen station.

Related to Plotter Environment

Fan Suction Setting (FAN POWER)

This function sets the suction force used to affix media to the plotter.
It may not feed properly if the media is thin, so decrease the suction force.

Operation

- 1 Press the [PAUSE/MENU] key in the default screen.

▶ MENU screen is displayed.



- 2 Press the POSITION (▼) key (ADV.).

▶ ADVANCE setting screen (1/2) is displayed.

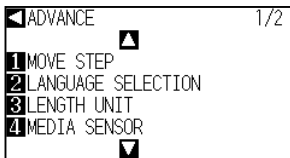

- 3 Press the POSITION (▲) key.

▶ ADVANCE setting screen (2/2) is displayed.

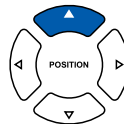
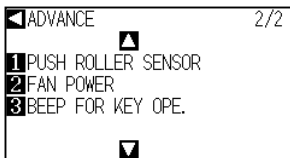

- 4 Press the [2] key (FAN POWER).

▶ FAN POWER setting screen is displayed.

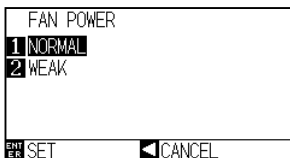

- 5 Press the [1] key (NORMAL) or the [2] key (WEAK).

- 6 Confirm the setting and press the [ENTER] key (SET).

▶ Setting will be set, and it will return to ADVANCE setting screen (2/2).

- 7 Press the [PAUSE/MENU] key.

▶ It will return to the default screen.

Supplement

Perform the settings in Normal menu.

Enabling/Disabling the Beep Setting (BEEP FOR KEY OPERATION)

This function selects whether to enable or disable the beep whenever a control panel key is pressed.

Operation

- 1 Press the [PAUSE/MENU] key in the default screen.

▶ MENU screen is displayed.



Supplement

Perform the settings in Normal menu.

- 2 Press the POSITION (▼) key (ADV.).

▶ ADVANCE setting screen (1/2) is displayed.

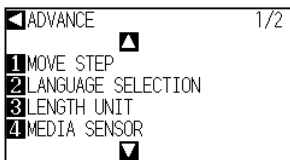

- 3 Press the POSITION (▲) key.

▶ ADVANCE setting screen (2/2) is displayed.

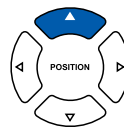
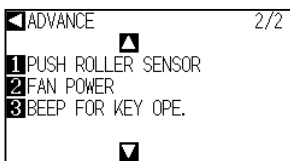

- 4 Press the [3] key (BEEP FOR KEY OPE.).

▶ BEEP FOR KEY OPE. setting screen is displayed.



- 5 Press the [1] key (ON) or the [2] key (OFF).

- 6 Confirm the setting and press the [ENTER] key (SET).

▶ Setting will be set, and it will return to ADVANCE setting screen (2/2).

- 7 Press the [PAUSE/MENU] key.

▶ It will return to the default screen.

Chapter 10: ***Settings of Controls from Computer***

This chapter describes setting regarding the controls from the computer.

Related to Command Processing

Setting the Command (COMMAND)

There are 2 types of commands, the GP-GL and the HP-GL, that the plotter can use. Match it to the software you are using.

Operation

- 1 Press the [PAUSE/MENU] key in the default screen.

▶ MENU screen is displayed.



- 2 Press the POSITION (▲) key (I/F).

▶ INTERFACE setting screen (1/3) is displayed.

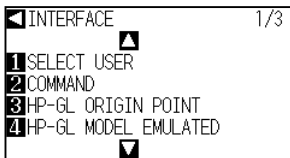

- 3 Press the [2] key (COMMAND).

▶ COMMAND setting screen is displayed.

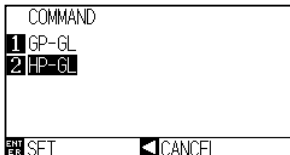

- 4 Press [1] key (GP-GL) or [2] key (HP-GL).

- 5 Confirm the setting and press the [ENTER] key (SET).

▶ Setting will be set, and it will return to INTERFACE setting screen (1/3).

- 6 Press the [PAUSE/MENU] key.

▶ It will return to the default screen.

Supplement

Perform the settings in Normal menu.

In Simple menu there are no settings. (It's in HP-GL mode.)

When a faulty judgment has been made in Simple menu, please use Normal menu where commands can be set.

Priority of Tool Condition Selection (CONDITION PRIORITY)

Select the priority of the setting created by different method when the tool condition is set.

All the tool condition that is received from the computer will be ignored, and only the setting and change of the tool condition from the control panel is accepted when MANUAL is selected. This setting set here is maintained even if the power is turned off.

On the other hand, it will set the most current tool condition either from the control panel or from the software when PROGRAM is selected. The values set from the control panel is maintained, and the values set from the software is erased when the power is turned off.

Operation

- 1 Press the [PAUSE/MENU] key in the default screen.

▶ MENU screen is displayed.

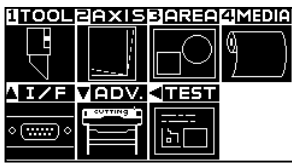

Supplement

Perform the settings in Normal menu.

- 2 Press the [1] key (TOOL).

▶ TOOLS SETTING screen (1/3) is displayed.

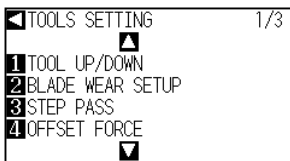

- 3 Press the POSITION (▲) key.

▶ TOOLS SETTING screen (2/3) is displayed.

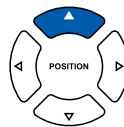
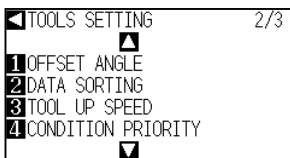

- 4 Press the [4] key (CONDITION PRIORITY).

▶ CONDITION PRIORITY setting screen is displayed.

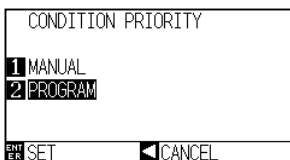

- 5 Press the [1] key (MANUAL) or the [2] key (PROGRAM).

- 6 Confirm the setting and press the [ENTER] key (SET).

▶ Setting will be set, and it will return to TOOLS SETTING screen (2/3).

- 7 Press the [PAUSE/MENU] key.

▶ It will return to the default screen.

Related to GP-GL Command

A useful chapter when using the GP-GL command.

Setting the Step Size (GP-GL STEP SIZE)

The distance to travel with 1 step can be changed. Match the setting value of the application to be used.

Operation

- 1 Press the [PAUSE/MENU] key in the default screen.

▶ MENU screen is displayed.



- 2 Press the POSITION (▲) key (I/F).

▶ INTERFACE setting screen (1/3) is displayed.

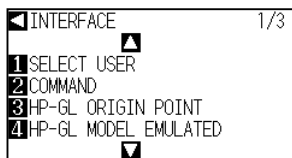

- 3 Press POSITION (▲) key.

▶ INTERFACE setting screen (2/3) is displayed.

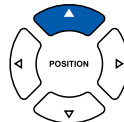
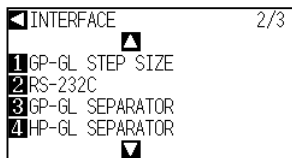

- 4 Press the [1] key (GP-GL STEP SIZE).

▶ GP-GL STEP SIZ setting screen is displayed.

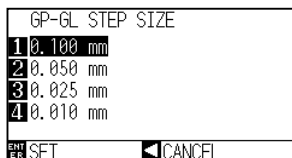

- 5 Press the [1] key (0.100 mm), the [2] key (0.050 mm), the [3] key (0.025 mm), or the [4] key (0.010 mm).

- 6 Confirm the setting and press the [ENTER] key (SET).

▶ Setting will be set, and it will return to INTERFACE setting screen (2/3).

- 7 Press the [PAUSE/MENU] key.

▶ It will return to the default screen.

Supplement

Perform the settings in Normal menu.

Enabling/Disabling the ':' and ';' Commands (COMMAND ':',';')

If the first part of the data is lost when the GP-GL command is set, these commands may be having an adverse effect. In this case, set the ':' and ';' commands to DISABLED.

Operation

- 1 Press the [PAUSE/MENU] key in the default screen.

▶ MENU screen is displayed.



- 2 Press the POSITION (▲) key (I/F).

▶ INTERFACE setting screen (1/3) is displayed.

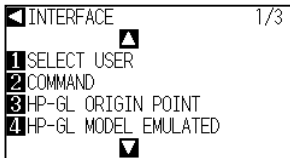

- 3 Press the POSITION (▼) key.

▶ INTERFACE setting screen (3/3) is displayed.

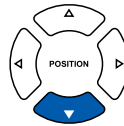
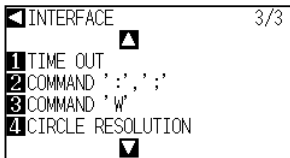

- 4 Press the [2] key (COMMAND ':',';').

▶ COMMAND ':',';' setting screen is displayed.

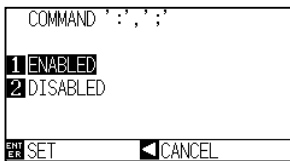

- 5 Press the [1] key (ENABLED) or the [2] key (DISABLED).

- 6 Confirm the setting and press the [ENTER] key (SET).

▶ Setting will be set, and it will return to INTERFACE setting screen (3/3).

- 7 Press the [PAUSE/MENU] key.

▶ It will return to the default screen.

Supplement

Perform the settings in Normal menu.

Moving the Pen While Raised or Lowered in Response to the 'W' Command (COMMAND 'W')

Here, you can change the settings for the 'W' command, which is a GP-GL arc cutting command.

This function set the operation upon receipt of the 'W' command for the drawing of arcs.

The pen will move to the specified starting position in the raised status when it is set to TOOL UP, regardless of the pen's conditions. The pen will move without changing its condition, to the specified starting position in the lowered status when it is set to TOOL DOWN.

Supplement

This only has an effect on the cutter tool.

Operation

- 1 Press the [PAUSE/MENU] key in the default screen.

▶ MENU screen is displayed.



Supplement

Perform the settings in Normal menu.

- 2 Press the POSITION (▲) key (I/F).

▶ INTERFACE setting screen (1/3) is displayed.

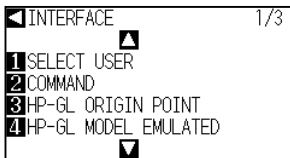

- 3 Press the POSITION (▼) key.

▶ INTERFACE setting screen (3/3) is displayed.

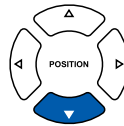
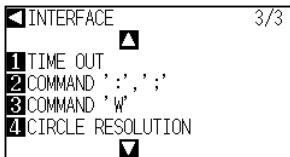

- 4 Press the [3] key (COMMAND 'W').

▶ COMMAND 'W' setting screen is displayed.

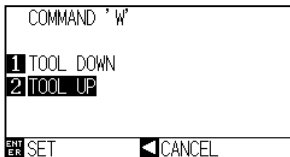

- 5 Press the [1] key (TOOL DOWN) or the [2] key (TOOL UP).

- 6 Confirm the setting and press the [ENTER] key (SET).

▶ Setting will be set, and it will return to INTERFACE setting screen (3/3).

- 7 Press the [PAUSE/MENU] key.

▶ It will return to the default screen.

Related to HP-GL Command

A useful chapter when using the HP-GL command.

Model ID Response (HP-GL MODEL EMULATED)

This function set the operation upon receipt of the "OI" command requesting for the model ID. The reply will be 7550 when set to 7550, and 7586 when set to 7586.

Operation

- 1 Press the [PAUSE/MENU] key in the default screen.

▶ MENU screen is displayed.



- 2 Press the POSITION (▲) key (I/F).

▶ INTERFACE setting screen (1/3) is displayed.

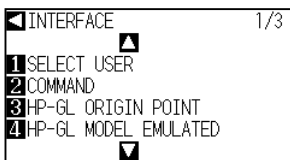

- 3 Press the [4] key (HP-GL MODEL EMULATED).

▶ HP-GL MODEL EMULATED setting screen is displayed.

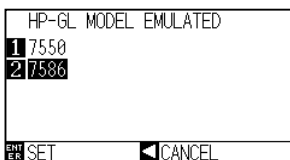

- 4 Press the [1] key (7550) or the [2] key (7586).

- 5 Confirm the setting and press the [ENTER] key (SET).

▶ Setting will be set, and it will return to INTERFACE setting screen (1/3).

- 6 Press the [PAUSE/MENU] key.

▶ It will return to the default screen.

Supplement

Perform the settings in Normal menu.

Circle-Command Resolution Setting (CIRCLE RESOLUTION)

This function set the sets the resolution upon receipt of the circle-command for the HP-GL pen plotter arc cutting command.

Select either "AUTO" or "DEFAULT", which is 5 degrees.

Operation

- 1 Press the [PAUSE/MENU] key in the default screen.

▶ MENU screen is displayed.



Supplement

Perform the settings in Normal menu.

- 2 Press the POSITION (▲) key (I/F).

▶ INTERFACE setting screen (1/3) is displayed.

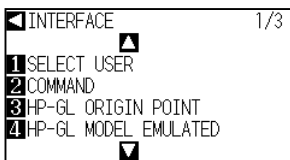

- 3 Press the POSITION (▼) key.

▶ INTERFACE setting screen (3/3) is displayed.

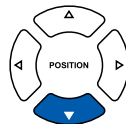
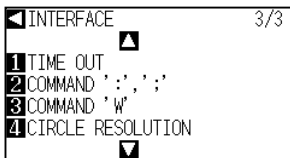

- 4 Press the [4] key (CIRCLE RESOLUTION).

▶ CIRCLE RESOLUTION setting screen is displayed.

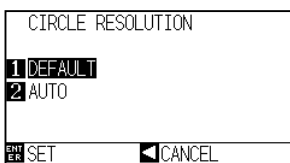

- 5 Press the [1] key (DEFAULT) or the [2] key (AUTO).

- 6 Confirm the setting and press the [ENTER] key (SET).

▶ Setting will be set, and it will return to INTERFACE setting screen (3/3).

- 7 Press the [PAUSE/MENU] key.

▶ It will return to the default screen.

Chapter 11: Maintenance

This chapter describes the settings for the maintenance.

PRODUCT SUMMARY

- 11.1 *Daily Maintenance***
- 11.2 *Replacing Cutter Blade***
- 11.3 *Cleaning the Cutter Pen***
- 11.4 *Cutter Plunger Exchange***

11.1

Daily Maintenance

Daily Maintenance

During the course of daily plotter operation, be sure to observe the following precautions:

- (1) Never lubricate the mechanisms of the plotter.
- (2) Clean the plotter's casing using a dry cloth that has been moistened in a neutral detergent diluted with water. Never use thinner, benzene, alcohol, or similar solvents to clean the casings; they will damage the casing's finish.
- (3) Clean the cutting mat using a dry cloth. In case of stubborn stains, use a cloth that has been moistened in alcohol or in a neutral detergent diluted with water.
- (4) Clean the plotter's paper sensors using a cloth moistened in a neutral detergent diluted with water.
 - * Never use thinner, benzene, alcohol, or similar solvents to clean the sensors; cleaners such as these will damage the sensors.
- (5) When the Y rail sliding surface gets dirty, gently wipe the dirt away with a clean, dry towel.
 - * The sliding surface has lubricant on it, so be sure not to wipe all the lubricant off as well.

Storing the Plotter

When your plotter is not in use, be sure to observe the following points:

- (1) Remove the tool attached to the tool holder.
- (2) Cover the plotter with a cloth to protect it from dust and dirt.
- (3) Do not store the plotter in direct sunlight or in high temperatures.
- (4) Please lower the set lever so the push roller is in a risen state.

11.2

Replacing Cutter Blade

Replace the cutter blade by referring to the structure diagram of the cutter pen.

Cutter Plunger Structure

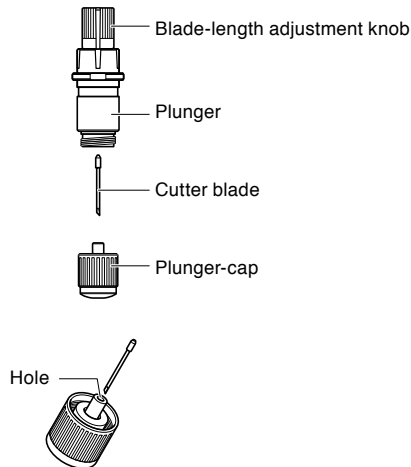

Supplement

See "Structure of Cutter Plunger" [P.2-2](#) for the structure of the cutter plunger.

Operation

- 1 Turn the blade-length adjustment knob in the direction of the B arrow and pull the blade into the plunger.

One scale unit
approximately 0.1 mm

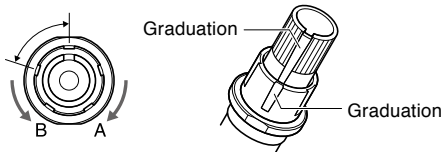

- 2 Turn the plunger cap in the counter-clockwise direction to remove it from the plunger.
- 3 Remove the blade from inside the plunger cap.
- 4 Remove a new blade from its pack. Insert the new blade into the hole provided in the plunger cap.
- 5 With the blade inserted into the plunger cap, screw on the plunger from above.
- 6 Fix the plunger cap by turning it clockwise.

11.3

Cleaning the Cutter Pen

Letting leftover media and paper dust build up on blades can dull them and cause them to deteriorate. Be sure to clean the cutter pen regularly and remove build up.

CAUTION

To avoid bodily injury, handle cutter blades with care.

Cleaning

- 1 Please clean off paper dust and media build up from the blade. After cleaning it, return it to its proper place. Spin the plunger cap, remove it, and then clean the blade entrance area.

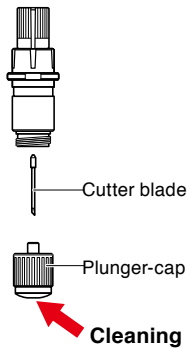

- 2 Attach the plunger cap.

11.4 *Cutter Plunger Exchange*

The tip of the cutter plunger gets worn down due to friction with the media.

When the tip of the cutter plunger gets worn down, cut quality suffers.

When the tip of the plunger cap gets worn down, it is recommended that you exchange the cutter plunger.

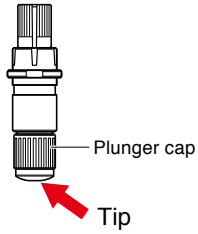

Chapter 12: Troubleshooting

Refer to this chapter if you feel something is wrong, or it does not work right.

It also describes the settings of the plotter, confirming the cutting data, and method to create test patterns.

PRODUCT SUMMARY

- 12.1 Troubleshooting***
- 12.2 Printing the Setting of the Plotter***
- 12.3 Creating Test Pattern***
- 12.4 Confirm the Cutting Data***
- 12.5 Cutting a CUT DEMO***
- 12.6 Self Diagnostic Test***

12.1

Troubleshooting

When the Plotter Does Not Operate After Turning the Power On

Symptom	Possible Cause	Solution
• Nothing is displayed on the LCD panel.	There is no power supplied. Or, the plotter is defective.	Check that the power cord is securely connected to the plotter's AC line inlet and the electrical outlet. Check that the power is supplied to the electrical outlet. Contact your Graphtec customer center if the problem still exists.
• "Sum-Ck ROM RAM ERR!!" is displayed on the LCD panel.	The ROM or RAM is defective.	Contact your Graphtec customer center if the problem still exists.

When It Does Not Work Right

Symptom	Possible Cause	Solution	Reference
• Drops the media while detecting.	Bright light might be shining onto the media sensor.	Block the light if there is direct sunlight shining on the plotter that is placed near the window. Move away the fluorescent lamps if there is one close to the plotter.	
	Media sensor may be defective.	Contact your sales representative or the Graphtec call center. Set the media sensor to DISABLED to use the plotter temporarily.	➔P.9-4 Enabling/Disabling the Media Sensors (MEDIA SENSOR)
• Media wobbles.	Push rollers are not set correctly on the grit rollers.	Check the position of the push rollers.	➔P.2-7 Loading Media (Paper)
	Changing of the hold-down force of the push roller is not suitable for the media.	Please set a media suitable for changing the hold-down force.	➔P.2-18 Changing the Hold-down Force
	Roll media is not set properly.	Set the roll media properly.	➔P.2-7 Loading Media (Paper)
• One of the push roller goes off the media.	The leading edge or the trailing edge of the media is not cut straight against the media.	Cut the edge of the media straight.	
• A "Position Error" appears when the tool carriage hits the left side of the device after setting the media and choosing a media type. Or a "Position Error" appears when it hits the right side of the device.	Push roller sensor may be defective if it hits the left side of the plotter. Home sensor may be defective if it hits the right side of the plotter.	Contact your sales representative or the Graphtec call center. Set the push roller sensor to DISABLED to use the plotter temporarily.	➔P.9-5 Enabling/Disabling the Push Roller Sensors (PUSH ROLLER SENSOR)
• The plotter stops with "POSITION ALARM" displayed during initialization or cutting.	CONDITION setting for the media is invalid.	Slow down the speed or lower the FORCE.	➔P.2-30 Setting the Tool Condition
	The pen carriage does not move by hitting something.	Move the object disturbing the operation, and turn on the plotter after turning it off once.	
	External force is applied to the pen carriage while cutting.	Move the object disturbing the operation, and turn on the plotter after turning it off once.	
	Movement is disturbed by the media chaff in the operation area.	Move the object disturbing the operation, and turn on the plotter after turning it off once.	
	The plotter is defective.	Contact your sales representative or the Graphtec call center.	
• It is cutting with origin point shifting to center of the media.	Data created with lower left origin point is received when the plotter is set with center origin point. (With HP-GL command)	Reset the origin point to center on the application software, or reset the origin point of the plotter to lower left.	➔P.3-9 Setting Origin Point When HP-GL is Set
• Media jumps out to forward side.	Selected wrong type of the media.	Check the type of media, "SHEET", "ROLL-1 REAR SET", or "ROLL-2 REAR SET".	➔P.2-26 Setting Feeding Method
• Displays command error.	Data sent to the plotter is not correct.	Check the data.	➔P.12-6 Error Message in GP-GL Command Mode ➔P.12-7 Error Message in HP-GL Command Mode
• It cannot cut above certain length.	Length of the cut is exceeding the length of the page set on the plotter.	Press the [FAST] key and check the cutting area. Match the setting for the page length.	➔P.4-5 Setting Length of the Page
• There are too many tool up and down.	Setting for the tangential mode is set to ON.	Turn OFF the setting for the tangential mode unless you are cutting thick media.	➔P.6-3 Setting the Tangential Mode

Symptom	Possible Cause	Solution	Reference
• It is cutting on the grit roller imprint.	Cutting width is widened.	Please revert the expand limit to the default setting.	➔P4-4 Setting Cutting Width
• Tool condition changes.	Setting of the priority is set to PROGRAM.	Change the setting of the priority to MANUAL.	➔P10-3 Priority of Tool Condition Selection (CONDITION PRIORITY)
	[ENTER] key is not pressed after changing the TOOL CONDITION.	Check the TOOL CONDITION again.	➔P2-30 Setting the Tool Condition
• Media travels tilted.	Media is loaded tilted.	Reload the media.	➔P2-7 Loading Media (Paper)
	Media is slipping.	Perform pre feed once and make impression to make it harder to slip.	➔P4-7 Setting the number of pre feeds
	Roll media is not set properly.	Set the roll media properly.	➔P2-7 Loading Media (Paper)
	Changing of the hold-down force of the push roller is not suitable for the media.	Please set a media suitable for changing the hold-down force.	➔P2-18 Changing the Hold-down Force
• It does not become specified length. (Slight distance error)	Media is slipping.	Make the speed slower. Increase the tool up speed. Perform feeding.	➔P2-30 Setting the Tool Condition ➔P4-7 Setting the number of pre feeds ➔P7-10 Setting the Tool Up Speed
	Distance adjust value is not correct.	Perform distance adjust.	➔P6-10 Setting the Distance Adjust
• "LOAD MEDIA!" is displayed even if the media is set and media set lever is moved up.	Media is close to transparent and media sensor makes false recognition. (This may happen depending on the media.)	Transparent media cannot be detected. DISABLE the media sensor and set the cut area when this kind of media is used.	➔P9-4 Enabling/ Disabling the Media Sensors (MEDIA SENSOR) ➔P4-2 Setting Cutting Area
	Media sensor malfunctions with strong scattered reflection.	Move the position of the light source. Make is so no direct sunlight shines.	
	There may be defective in the operation of the media set lever sensor.	Contact your sales representative or the Graphtec call center.	

When the Cutting Result is Not Good

Symptom	Cause	Solution
<ul style="list-style-type: none"> • Corners are rounded. • Corners are too sharp. 	Blade and OFFSET does not match.	Change the OFFSET. → It is rounded: Increase the OFFSET → It is too sharp: Decrease the OFFSET
<ul style="list-style-type: none"> • The cut line starts out crooked. 	The blade inside the plunger doesn't turn smoothly.	Remove dirt from inside the plunger.
<ul style="list-style-type: none"> • The blade skips and does not completely cut lines that should be solid. • Straight cut lines seems to wobble. 	The blade is extended too far.	Adjust the blade length.
	The cutting speed is too high.	Lower the speed setting.
<ul style="list-style-type: none"> • Coarse resolution of curved lines. 	The software's resolution setting is too low.	Adjust the software's resolution setting.
	The blade offset angle is too low.	Increase the value for the blade offset angle.
<ul style="list-style-type: none"> • The media curls up at the corners. • The figure cut during plotting gets torn. 	The blade is extended too far.	Adjust the blade length.
	Blade and OFFSET does not match.	Change the OFFSET.
	The cutting speed is too high.	Lower the speed setting.
	The blade is dull.	Replace the blade.
	The ACCELERATION setting is too high.	Lower the ACCELERATION setting.
	The FORCE (cutting) is too high.	Lower the FORCE setting.
	CUT LINE PATTERN setting is not set properly.	Change CUT LINE PATTERN settings.
<ul style="list-style-type: none"> • The blade falls out of the tool plunger. 	The blade is too small for the tool plunger.	Use a blade that fits securely in the tool plunger.
<ul style="list-style-type: none"> • Abnormal noise generated from the tool carriage during cutting. • The media is discolored where the blade has passed. 	Media is rubbed by the tip of the tool plunger.	Adjust the blade length and the cutting FORCE settings.
<ul style="list-style-type: none"> • The cutting results differ from the specified size. 	The STEP SIZE has been set differently at the computer and the plotter.	Set the STEP SIZE to same value.
	Scaling has been specified on the computer.	Check whether scaling has been specified.
<ul style="list-style-type: none"> • Currently selected cutting conditions are disregarded or cannot be changed. 	The parameter priority setting is set to PROGRAM.	Change the setting of the priority to MANUAL.
	The [ENTER] key was not pressed after changing the settings.	Check the operation.
<ul style="list-style-type: none"> • Characters or lines are deformed during pen plotting. 	The plotter is in cutting mode.	Select PEN as the tool in the CONDITION setting.
<ul style="list-style-type: none"> • It does not become specified length. (Slight distance error) 	Distance adjust value is not correct.	Perform distance adjust.
<ul style="list-style-type: none"> • Characters are deformed. • Complex drawings are deformed. 	The STEP PASS setting is set too high.	Lower the STEP PASS setting.
<ul style="list-style-type: none"> • The starting and end points of cutting do not match. 	Coordinate points are incorrectly specified.	Check the coordinate data by plotting it with a pen.
	Blade rotation is not smooth.	Check that there is no dirt in the blade.

Error Messages in GP-GL Command Mode

Error Displayed	LCD Display	Cause	Solution
E02001	<p>The LCD display shows the error code E02001, the message 'GP-GL ERROR 1 COMMAND ERROR!', and navigation options: 1 VIEW, 2 HOME, and CONFIRM. The background shows '1:Condition No. 1' and 'CONDITION No.'.</p>	The plotter received an unrecognizable command.	Press the [ENTER] key.
		Noise came in when the computer was turned on.	Configure to drive the plotter from the menu of the software.
		The software configuration regarding the output device has been changed.	Reset the interface settings of the software.
		The plotter's interface conditions have changed.	Reset the interface settings of the plotter.
E02004	<p>The LCD display shows the error code E02004, the message 'GP-GL ERROR 4 PARAMETER OVERFLOW!', and navigation options: 1 VIEW, 2 HOME, and CONFIRM. The background shows '1:Condition No. 1' and 'CONDITION No.'.</p>	A command was received containing numeric parameters that exceed that command's permissible range.	Configure to drive the plotter from the menu of the software.
		The software configuration regarding the output device has been changed.	Reset the interface settings of the software.
		The plotter's interface conditions have changed.	Reset the interface settings of the plotter.
E02005	<p>The LCD display shows the error code E02005, the message 'GP-GL ERROR 5 I/O ERROR!', and navigation options: 1 VIEW, 2 HOME, and CONFIRM. The background shows '1:Condition No. 1' and 'CONDITION No.'.</p>	An error occurred in the receipt of data within the interface.	Configure to drive the plotter from the menu of the software.
		The software configuration regarding the output device has been changed.	Reset the interface settings of the software.
		The plotter's interface conditions have changed.	Reset the interface settings of the plotter.
E02006	<p>The LCD display shows the error code E02006, the message 'GP-GL ERROR 6 OFF SCALE ERROR!', and navigation options: 1 VIEW, 2 HOME, and CONFIRM. The background shows '1:Condition No. 1' and 'CONDITION No.'.</p>	The data out of cutting range has been received.	Check the data.
			Check the size of media and the cutting range.
			Check the magnification setting.
			Check the step size settings.





Error Messages in HP-GL Command Mode

If any of the following command errors occur, they are nearly always caused by following 2 reasons.

1. The configuration regarding the output device in the application software has changed.
2. The plotter's interface conditions have changed.

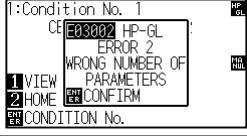
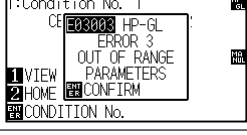
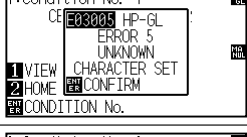
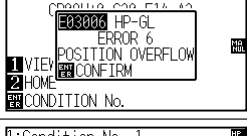
Perform following if these are the cause of the problem.

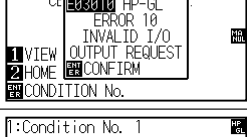
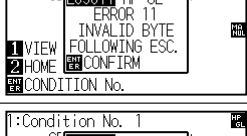
1. Reconfigure the output device of the application software to the plotter.
2. Reconfigure the plotter's interface conditions.

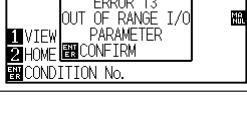

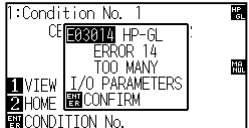
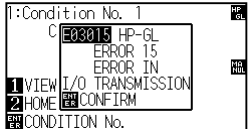
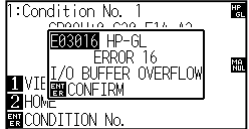





Error Displayed	LCD Display	Cause	Solution
E03001 Error 1		An unrecognizable instruction was executed.	Execute a recognizable command.
E03002 Error 2		Wrong number of parameters were specified.	Execute the command with the correct number of parameters.
E03003 Error 3		An unusable parameter was executed.	Execute a recognizable parameter.
E03005 Error 5		An unusable character set was specified.	Specify usable character set.
E03006 Error 6		Coordinates of command specified out of cutting area.	Execute coordinates within the cutting area.
E03007 Error 7		The data being input exceeds the capacity of the plotter's downloadable character buffer, polygon buffer, etc.	Adjust the buffer size.
E03010 Error 10		Other output command was executed while executing an output command.	Check the program.
E03011 Error 11		An invalid byte was received after ESC code.	Check the program.
E03012 Error 12		Invalid byte was received within device control command.	Check the program.
E03013 Error 13		A parameter outside of the permissible range was specified in the I/O related command.	Check the program.

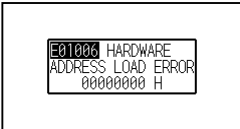





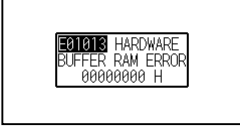

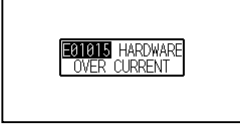
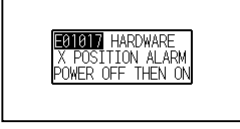
Error Displayed	LCD Display	Cause	Solution
E03014 Error 14		Too many parameters in the I/O related command.	Check the program.
E03015 Error 15		Framing error, parity error, or overrun error has occurred.	Set the RS-232C transmission condition.
E03016 Error 16		Interface buffer memory has overflowed.	Set the RS-232C transmission condition.

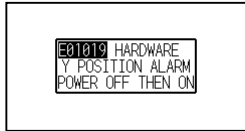
AXIS Error Messages

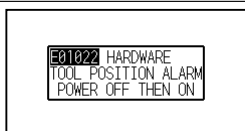
Symptom	LCD Display	Possible Cause	Solution
E04001		Tilt to adjust with AXIS ALIGNMENT is too large.	Reload the media.

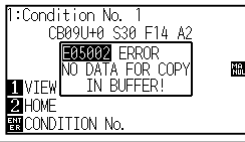
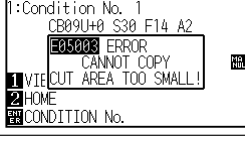
Other Error Messages

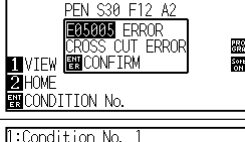
Symptom	LCD Display	Possible Cause	Solution
E01001 to E01005		The plotter is defective.	Contact your sales representative or the Graphtec call center.
E01006		The plotter is defective.	Contact your sales representative or the Graphtec call center.
E01007		The plotter is defective.	Contact your sales representative or the Graphtec call center.
E01008		The plotter is defective.	Contact your sales representative or the Graphtec call center.
E01009		The plotter is defective.	Contact your sales representative or the Graphtec call center.
E01010		The plotter is defective.	Contact your sales representative or the Graphtec call center.
E01011		The plotter is defective.	Contact your sales representative or the Graphtec call center.
E01012		The plotter is defective.	Contact your sales representative or the Graphtec call center.
E01013		The plotter is defective.	Contact your sales representative or the Graphtec call center.
E01014		The plotter is defective.	Contact your sales representative or the Graphtec call center.
E01015		The plotter is defective.	Contact your sales representative or the Graphtec call center.
E01017		The plotter is defective. Load on the motor was too large.	Move the object disturbing the operation, and turn on the plotter after turning it off once. Do not use heavy media.

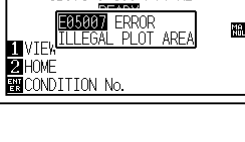
Symptom	LCD Display	Possible Cause	Solution
E01019		The plotter is defective. Load on the motor was too large.	Move the object disturbing the operation, and turn on the plotter after turning it off once. Do not use heavy media.
E01021		The plotter is defective. Load on the motor was too large.	Move the object disturbing the operation, and turn on the plotter after turning it off once. Do not use heavy media.
E01022		The plotter is defective. There was a heavy load on the up and down function of the tool carriage.	Please clear any obstruction in the up and down function of the tool carriage and turn the power back on. If the error display continues to show, please contact the store where you bought the product or our Customer Center.
E05001		Data larger than the buffer size cannot be copied.	Perform normal cutting not using the copy mode.
E05002		There is no data to copy.	Perform normal cutting by sending the data, then use the copy mode.
E05003		Media valid area to copy is too small.	Use larger media. Confirm the copy start position.
E05004		The push roller is not on the grit roller.	Set the push roller on the grit roller.
E05005		Unable to perform cross cut.	Unable to separate media cuts. Check tool blade and confirm media type.
E05006		Distance between the bottom left and top right of the AREA setting is less than 10 mm.	Perform the AREA setting again.
E05007		Test pattern for the TOOL OFFSET ADJ. cannot start plotting because the start position is at the edge of the media.	Set the start position inside the media.

Caution Message

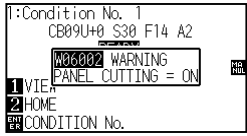
Symptom	LCD Display	Description
W06002	 <p>1:Condition No. 1 CB09U+0 S30 F14 A2 W06002 WARNING PANEL CUTTING = ON 1 VIEW 2 HOME 3 CONDITION No.</p>	When panel cutting is on, copy cannot be changed.

12.2

Printing the Setting of the Plotter

Condition setting list can be printed when you need to check the current setting of the plotter.

CAUTION

- Do not place your hand around the moving areas. The tool carriage will start moving, so there is a chance of injury. Tool carriage will start to move immediately after selecting to print the CONDITION list.
- Once you start printing, pause/cancel can not be performed in the middle.

Operation

- 1 Set a media larger than A1 size.
- 2 Select the pen plunger condition setting and place the pen plunger in the pen holder.

Supplement

See "Loading Media (Paper)" [P.2-7](#) for loading the media.

- 3 Press the [PAUSE/MENU] key in the default screen.

▶ MENU screen is displayed.



Supplement

- Please choose Condition No.2 when selecting the tool conditions for operating with the pen plunger.
- For setting the pen plunger, see "Attaching a Tool" [P.2-4](#).
- For changing the tool conditions, see "Selecting Tool Condition" [P.2-29](#), and for tool settings, see "Setting the Tool Condition" [P.2-30](#).

- 4 Press the POSITION (◀) key (TEST).

▶ TEST menu screen (1/2) is displayed.

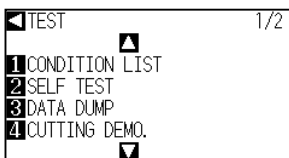

Supplement

Perform the settings in Normal menu.

- 5 Press the [1] key (CONDITION LIST).

▶ CONDITION LIST print screen is displayed.

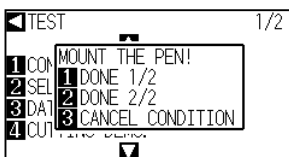

6 Press the [1] key (DONE 1/2) or the [2] key (DONE 2/2).

▶ Message to confirm tool position is displayed.

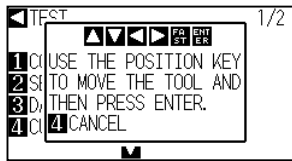

7 Move the tool carriage to print start position by pressing the POSITION (▲▼◀▶) key.

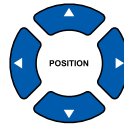

8 Confirm that movable parts of the tool and media can safely operate and press the [ENTER] key.

▶ Selected page of the CONDITION LIST is printed.

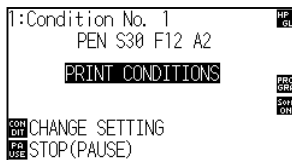

9 It will return to READY status when the printing is completed.

10 Press the [PAUSE/MENU] key.

▶ It will return to READY status when the printing is completed.

Supplement

Press the [3] key (CANCEL CONDITION) to return to the TEST menu screen without printing the list.

CAUTION

Do not place your hand around the moving areas. The tool carriage will start moving, so there is a chance of injury.

Supplement

Set the media and repeat steps 6 to 8 to print different page at this point.

12.3 Creating Test Pattern

Create a self-test pattern to check the operation of the plotter.

CAUTION

Do not place your hand around the moving areas. The tool carriage will start moving, so there is a chance of injury. Tool carriage will start to move immediately after selecting to plot the test pattern.

Operation

- 1 Set a media larger than A1 size.
- 2 Select the pen plunger condition setting and place the pen plunger in the pen holder.

Supplement

See "Loading Media (Paper)" [P.2-7](#) for loading the media.

- 2 Select the pen plunger condition setting and place the pen plunger in the pen holder.

Supplement

- Please choose Condition No.2 when selecting the tool conditions for operating with the pen plunger.
- For setting the pen plunger, see "Attaching a Tool" [P.2-4](#).
- For changing the tool conditions, see "Selecting Tool Condition" [P.2-29](#), and for tool settings, see "Setting the Tool Condition" [P.2-30](#).

- 3 Press the [PAUSE/MENU] key in the default screen.

▶ MENU screen is displayed.



Supplement

Perform the settings in Normal menu.

- 4 Press the POSITION (◀) key (TEST).

▶ TEST menu screen (1/2) is displayed.

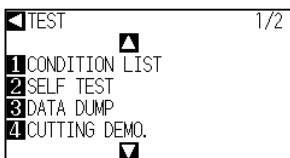

- 5 Press the [2] key (SELF TEST).

▶ SELF TEST start screen is displayed.

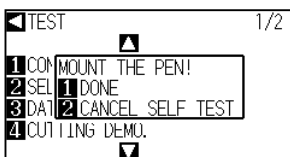

- 6 Confirm that the pen tool is set.
- 7 Confirm that operation area of tool and media is safe.

- 8 Press the [1] key (DONE).
 - ▶ Plotting of the test pattern starts.

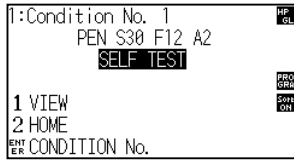

- 9 Turn the power off to stop the printing.

 **CAUTION**

Do not place your hand around the moving areas. The tool carriage will start moving, so there is a chance of injury.

Supplement

It will return to TEST menu screen without printing by pressing the [2] key (CANCEL SELF TEST).

Supplement

It will keep on printing until the power is turned off once the printing is started by pressing the [1] key (DONE).

12.4

Confirm the Cutting Data

Output of the dump list of the cutting data received by the plotter is possible. It is used to check if the transmission of cutting data is performed correctly.

CAUTION

Do not place your hand around the moving areas. The tool carriage will start moving, so there is a chance of injury. Tool carriage will start to move immediately after selecting to print the dump list.

Supplement

- There may be a difference in the RS-232C transmission condition or the command setting when the printed output and the display of transmission data does not match. Check the transmission condition and the command.
- Please set the command to "GP-GL" or "HP-GL".

Operation

- 1 Set a media larger than A1 size.
- 2 Select the pen plunger condition setting and place the pen plunger in the pen holder.

Supplement

See "Loading Media (Paper)" [➔ P.2-7](#) for loading the media.

Supplement

- Please choose Condition No.2 when selecting the tool conditions for operating with the pen plunger.
- For setting the pen plunger, see "Attaching a Tool" [➔ P.2-4](#).
- For changing the tool conditions, see "Selecting Tool Condition" [➔ P.2-29](#), and for tool settings, see "Setting the Tool Condition" [➔ P.2-30](#).

- 3 Press the [PAUSE/MENU] key in the default screen.

▶ MENU screen is displayed.



Supplement

Perform the settings in Normal menu.

- 4 Press the POSITION (◀) key (TEST).

▶ TEST menu screen (1/2) is displayed.

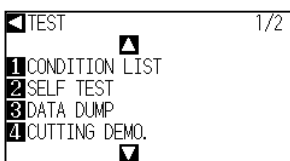

5 Press the [3] key (DATA DUMP).

▶ DATA DUMP start screen is displayed.

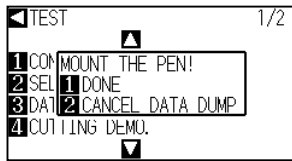

6 Confirm that the pen tool is set.

7 Confirm that operation area of tool and media is safe.

8 Press the [1] key (DONE).

▶ Output of the dump list starts.

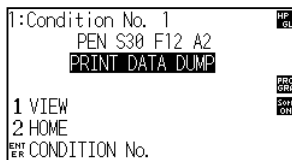

9 Turn the power off to stop the printing.

CAUTION

Do not place your hand around the moving areas. The tool carriage will start moving, so there is a chance of injury.

Supplement

It will return to TEST menu screen without printing by pressing the [2] key (CANCEL DATA DUMP).

Supplement

It will keep on printing until the power is turned off once the printing is started by pressing the [1] key (DONE).

12.5 Cutting a CUT DEMO

To check the operation of this unit, plot a pattern of cut demo.

Supplement

Diagnostic test can be performed only right after the power is turned on. DIAGNOSTICS cannot be selected from the menu once any operation, such as loading media, is performed.

Operation

- 1 Set a media larger than A1 size.
- 2 Select the pen plunger condition setting and place the pen plunger in the pen holder.

Supplement

See "Loading Media (Paper)" [P.2-7](#) for loading the media.

- 3 Press the [PAUSE/MENU] key in the default screen.

▶ MENU screen is displayed.



Supplement

- Please choose Condition No.2 when selecting the tool conditions for operating with the pen plunger.
- For setting the pen plunger, see "Attaching a Tool" [P.2-4](#).
- For changing the tool conditions, see "Selecting Tool Condition" [P.2-29](#), and for tool settings, see "Setting the Tool Condition" [P.2-30](#).

- 4 Press the POSITION (◀) key (TEST).

▶ TEST menu screen (1/2) is displayed.

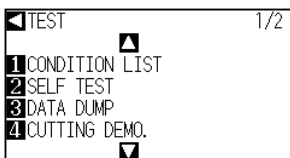

Supplement

Perform the settings in Normal menu.

- 5 Press [5] key (CUTTING DEMO.).

▶ CUTTING DEMO. screen is displayed.

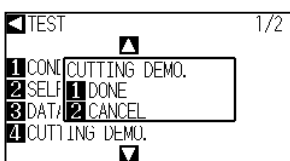

- 6 Confirm that the pen tool is set.

- 7 Confirm that operation area of tool and media is safe.
- 8 Press [1] key (DONE).
 - ▶ CUT DEMO is started.
- 9 When you start a cutting, TEST screen (1/2) is displayed.
- 10 Press the [PAUSE/MENU] key.
 - ▶ It will return to default screen.

 **CAUTION**

Do not place your hand around the moving areas. The tool carriage will start moving, so there is a chance of injury.

Supplement

Press [2] key (CANCEL) to return to the TEST screen without outputting the CUT DEMO.

Supplement

During operation, the keys on the control panel do not work. When the CUT DEMO output is finished, they are active.

12.6

Self Diagnostic Test

Operation status can be tested by self diagnostic test by operating the sensors and switches following the instruction on the screen.

Supplement

Diagnostic test can be performed only right after the power is turned on. DIAGNOSTICS cannot be selected from the menu once any operation, such as loading media, is performed.

Operation

- 1 Confirm that the power is turned off.
- 2 Turn the power on without loading the media.
- 3 Press the [PAUSE/MENU] key in the default screen.

▶ MENU screen is displayed.



Supplement

Perform the settings in Normal menu.

- 4 Press the POSITION (◀) key (TEST).

▶ TEST menu screen (1/2) is displayed.

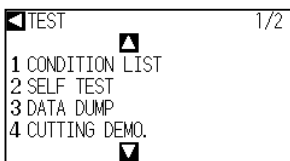

- 5 Press the POSITION (▲) key.

▶ TEST menu screen (2/2) is displayed.

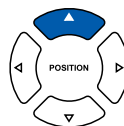
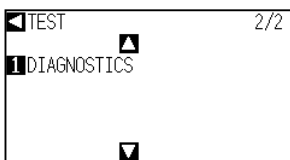

- 6 Press the [1] key (DIAGNOSTICS).

▶ DIAGNOSTICS start screen is displayed.

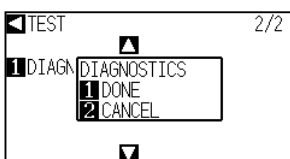

7 Press the [1] key (DONE).

- ▶ Messages for testing are displayed on the screen.

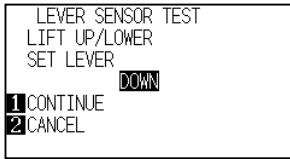

8 Operate switches and sensors following the instructions on the screen.

- ▶ "NORMAL" will be displayed if the operation is detected correctly, and next test will start.
- ▶ It will return to TEST menu screen once all the test items are completed.

Test items are as following.

1	Set lever sensor	2	Home sensor	3	Push roller sensor	4	-X media sensor
5	+X media sensor	6	X motor signal	7	Y motor signal	8	Tool height signal
9	[1] key	10	[2] key	11	[3] key	12	[4] key
13	POSITION [▶] key	14	POSITION [◀] key	15	POSITION [▼] key	16	POSITION [▲] key
17	[ENTER] key	18	[COND/TEST] key	19	[ORIGIN] key	20	[FAST] key
21	[SIMPLE] key	22	[COPY] key	23	[PAUSE/MENU] key		

Appendix

This chapter describes the specification of the plotter.

PRODUCT SUMMARY

- A.1** *Main Specifications*
- A.2** *Supplies*
- A.3** *External Dimensions*
- A.4** *Menu Tree*
- A.5** *Initial Setting*

A.1

Main Specifications

	CE6000-120AP
CPU	32bit CPU
Configuration	Grit-rolling plotter
Drive	Digital servo
Max. Cut Area	1190 mm × 50 m
Guaranteed precision cutting area*1	1190 mm × 3 m
Mountable media width*2	Min: 594 mm Max: 1220 mm
Diameter of mountable rolls	3-inch paper core
Available roll media diamete	Max. diameter: 200 mm
Mountable roll paper (media)	20 kg or less
The number of push roller	5
Max. cutting speed	600 mm/s (Omnidirectiona)
Specifiable speeds (cm/s)	1 to 10, 15, 20, 25, 30, 35, 40,45, 50, 55, 60 (Max. 30 cm/s during PANEL CUTTING)
Cutting Pressure	0.2 to 4.41 N (20 to 450 gf) 38 steps
Min. character size	5 mm alphanumeric Helvetica med. Font
Mechanical resolution	0.005 mm
Program mable resolution	GP-GL : 0.1/0.05/0.025/0.01 mm HP-GL*4 : 0.025 mm
Repeatable accuracy*1 *3	Max. 0.1 mm unit of 2 m (Designated Film and Cut Conditions)
Number of cutters/pens	2
Usable pen type	Water-based fiber-tip and oil-based ballpoint
Interface	RS-232C/USB2.0 (Full Speed)
Buffer memory	2 MB
Resident command sets	GP-GL/HP-GL*4 (Control panel switching)
LCD display	Graphic type (240 × 128 dot)
Power supply	AC100-120 V, 200-240 V, 50/60 Hz
Power consumption	120 VA or less
Operating environment	10 to 30°C, 35 to 75 % R.H. (non-condensing)
Guaranteed accuracy environment	18 to 28°C, 40 to 65 % R.H. (non-condensing)
External dimensions (W × D × H)	1575×1200×250 mm (Including stand)
Weight	46 kg (Including stand)

*1: Dependent on the media condition settings specified by this com our company.

*2: Describes the usable paper width. Accuracy assurance for the minimum paper width is the width when the push roller is set to 5 mm inside of both sides of the media.

*3: Please be aware that the accuracy of this machine is measured against Graphtec Mylar film.
This machine takes only quality coated (glossy) paper

*4: HP-GL is a registered trademark of the US Hewlett Packard Company.

A.2

Supplies

Supplies

Item	Model	Contents
Cutter plunger	PHP33-CB09N-HS	Used with ϕ 0.9 mm diameter cutter blades
	PHP33-CB15N-HS	Used with ϕ 1.5 mm diameter cutter blades
Water-based fiber-tip pen plunger	PHP31-FIBER	Plunger for water-based fiber-tip pen (set of 1)
Water-based fiber-tip pen	KF700-BK	1 set (10 pcs. Black)
	KF700-RD	1 set (10 pcs. Red)
	KF700-BL	1 set (10 pcs. Blue)
Oil-based ballpoint pen plunger	PHP34-BALL	Plunger for oil-based ballpoint pen (set of 1)
Oil-based ballpoint pen	KB700-BK	1 set (10 pcs. Black)

For detailed information about the cutter blade, refer to the Cutter Blade Manual.

Please check our company's home page for the latest information on supplies.

A.3

External Dimensions

CE6000-120AP

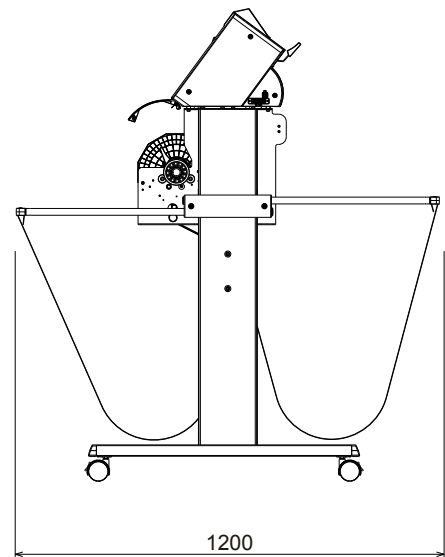
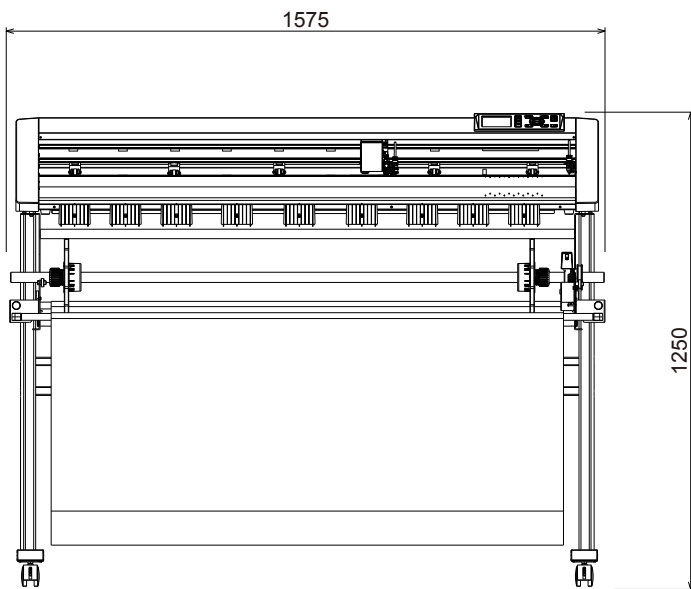
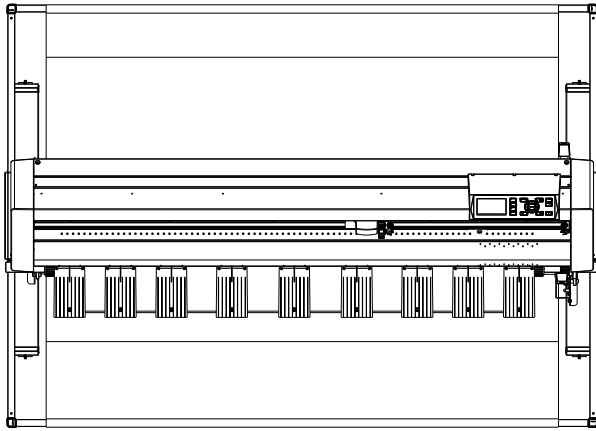

Unit: mm
Dimensional accuracy: $\pm 5\text{mm}$

A.4

Menu Tree

Simple Menu

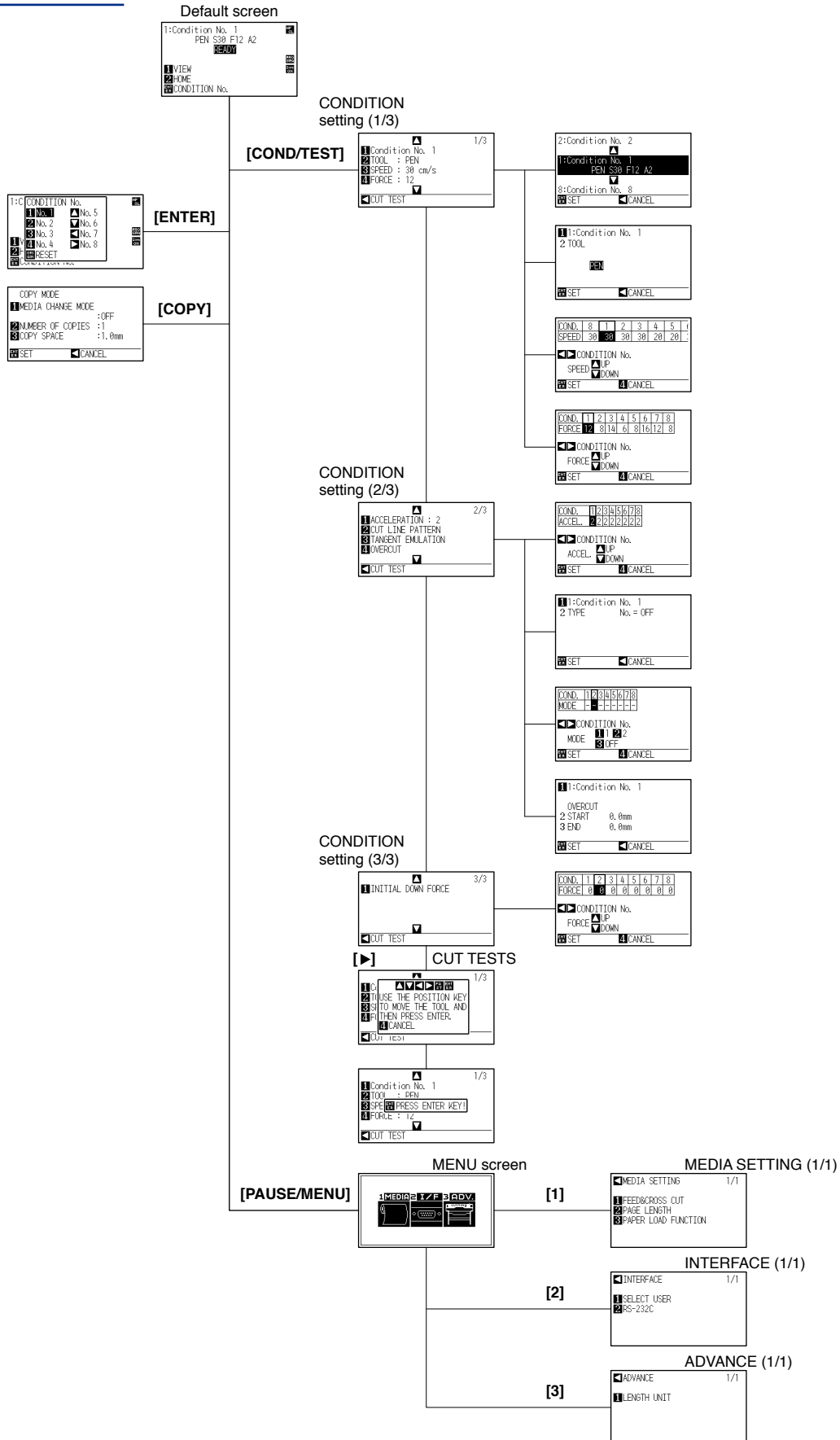

Normal Menu

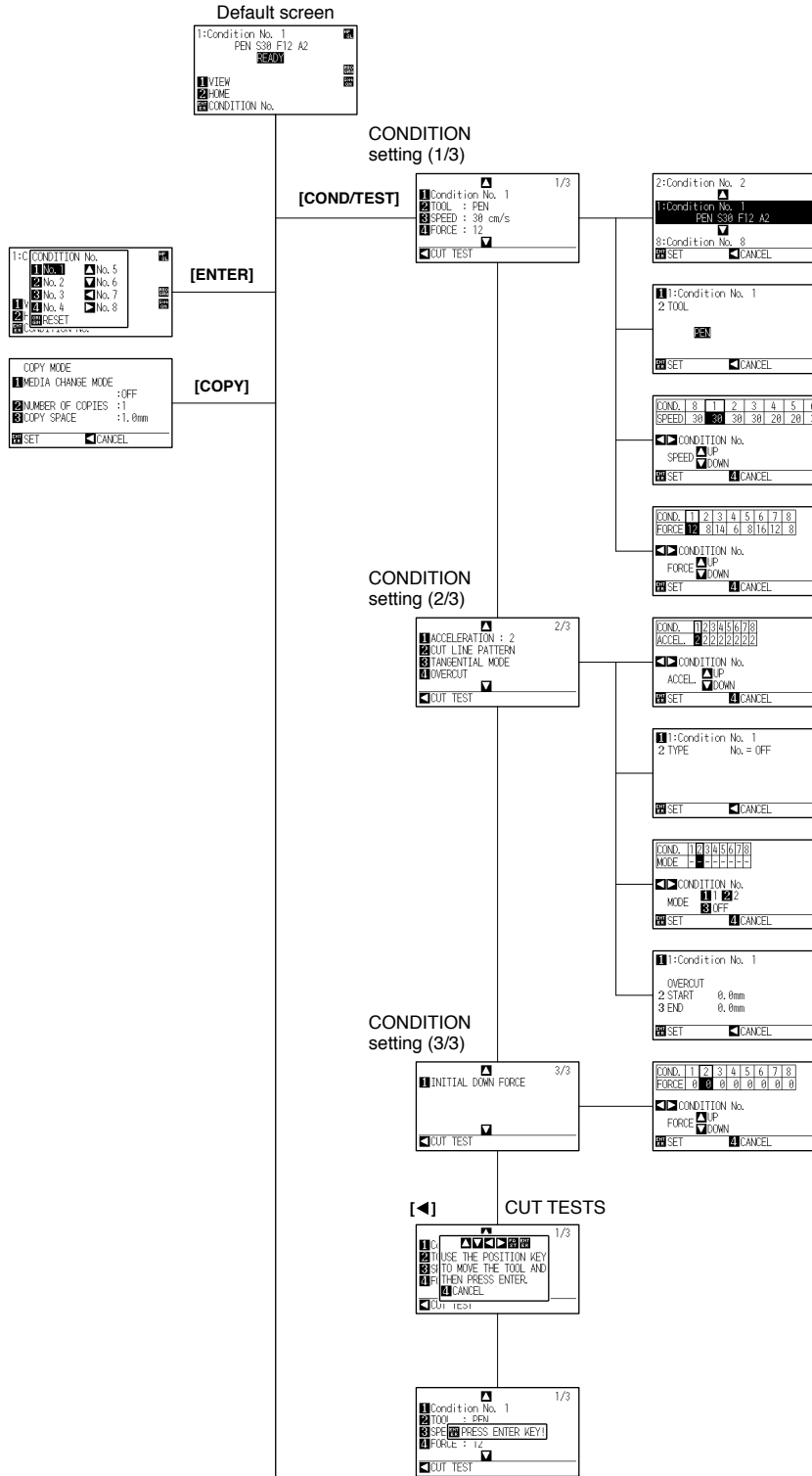

Continued

Default screen (Continued)

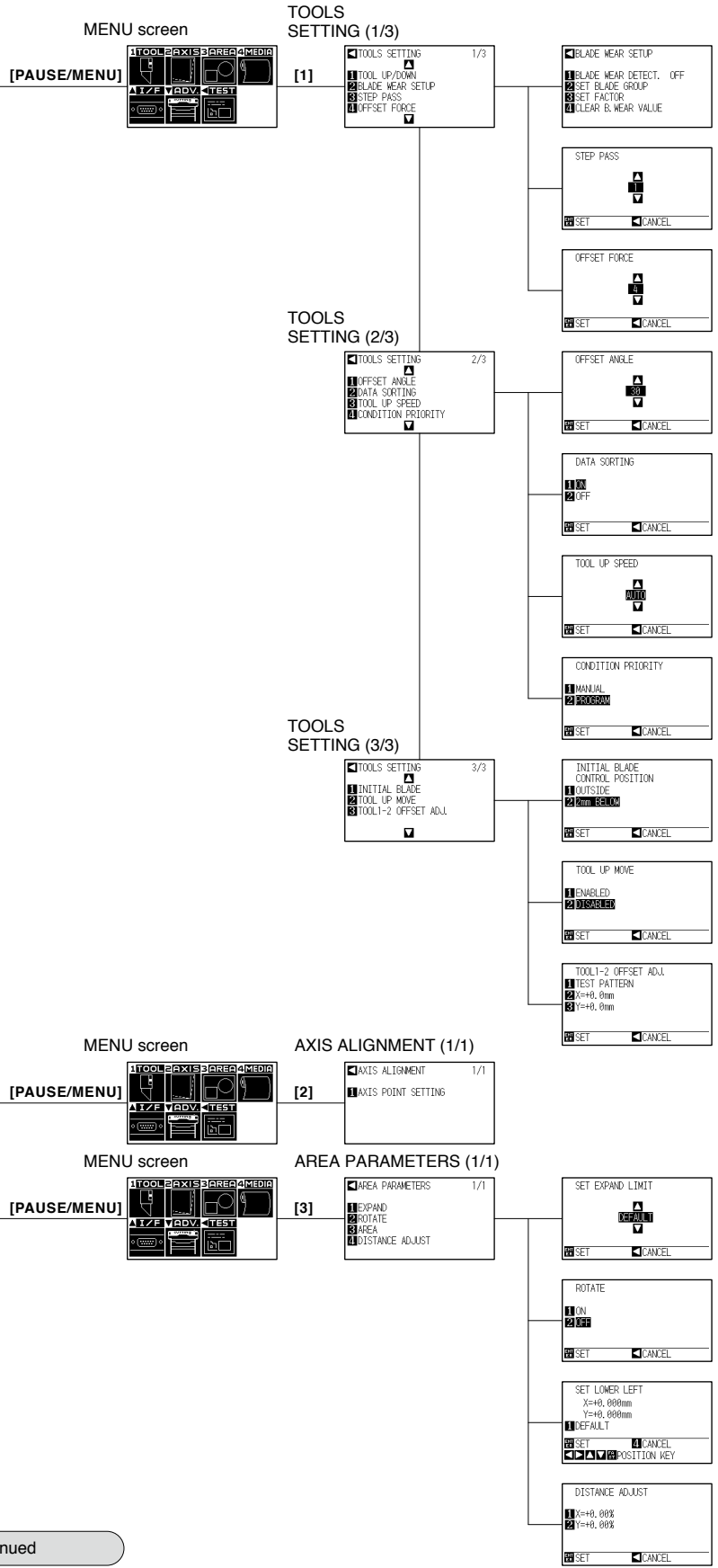

Continued

Default screen (Continued)

MENU screen

[PAUSE/MENU]



MEDIA SETTING (1/3)

MEDIA SETTING 1/3
[4]
1 FEED&CROSS CUT
2 F COMMAND CUT
3 CROSS OUT FORCE
4 CROSS CUT

FEED&CROSS CUT
1 FEED&CROSS CUT (exe)
2 CROSS OUT (execute)
CANCEL

F COMMAND CUT
1 ON
2 OFF
SET CANCEL

CROSS OUT FORCE
A 20
B 10
C 5
D 2
E 1
F 0.5
G 0.2
H 0.1
SET CANCEL

CROSS CUT
1 ON
2 OFF
SET CANCEL

MEDIA SETTING (2/3)

MEDIA SETTING 2/3
1 PAGE LENGTH
2 AUTO PRE FEED
3 FEED SPEED
4 INITIAL FEED

PAGE LENGTH
A 300.0cm
B 1.000
SET CANCEL

AUTO PRE FEED
1 OFF
2 FEED LENGTH
1.0m
SET CANCEL

FEED SPEED
1 SLOW
2 NORMAL
3 FAST
SET CANCEL

INITIAL FEED
1 ON
2 OFF
SET CANCEL

MEDIA SETTING (3/3)

MEDIA SETTING 3/3
1 PAPER LOAD FUNCTION
2 PAPER READY TIME
3 PANEL CUTTING
4 SPACE REAR

PAPER LOAD FUNCTION
A ON
B OFF
SET CANCEL

PAPER READY TIME
A 100sec
B 150sec
C 200sec
D 300sec
E 400sec
F 500sec
G 600sec
H 700sec
I 800sec
J 900sec
K 1000sec
L 1100sec
M 1200sec
N 1300sec
O 1400sec
P 1500sec
Q 1600sec
R 1700sec
S 1800sec
T 1900sec
U 2000sec
V 2100sec
W 2200sec
X 2300sec
Y 2400sec
Z 2500sec
SET CANCEL

PANEL CUTTING
1 OFF
2 DIVIDE LENGTH
100.0cm
SET CANCEL

SPACE REAR
A 1.000
B 1.500
C 2.000
D 2.500
E 3.000
F 3.500
G 4.000
H 4.500
I 5.000
J 5.500
K 6.000
L 6.500
M 7.000
N 7.500
O 8.000
P 8.500
Q 9.000
R 9.500
S 10.000
T 10.500
U 11.000
V 11.500
W 12.000
X 12.500
Y 13.000
Z 13.500
SET CANCEL

Continued

Default screen (Continued)

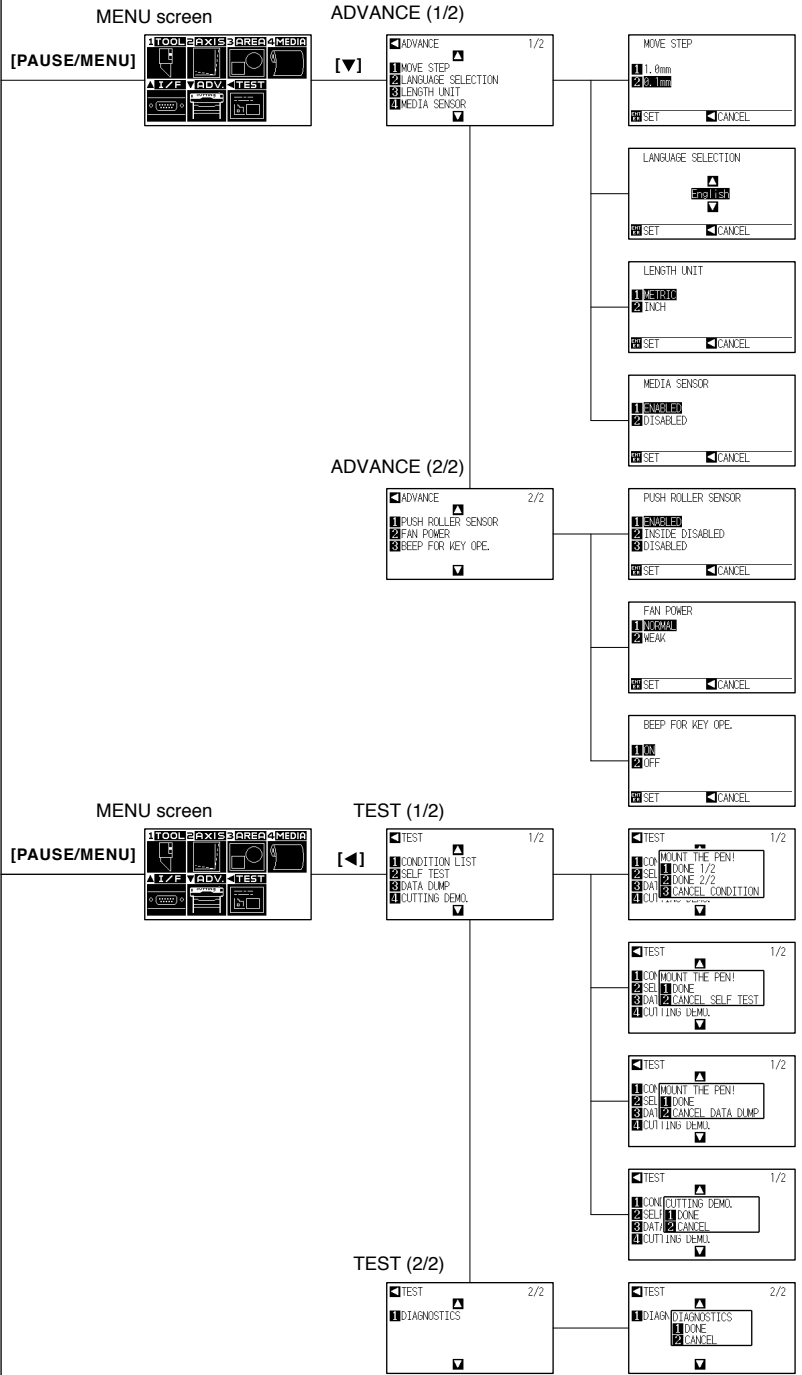

Default screen (Finish)

Menu items		Setting items	Initial value	
ADVANCE		MOVE STEP	0.1 mm	
		LANGUAGE SELECTION	Select when initially turning on power	
		LENGTH UNIT	Select when initially turning on power	
		MEDIA SENSOR	ENABLED	
		PUSH ROLLER SENSOR	ENABLED	
		FAN POWER	NORMAL	
		BEEP FOR KEY OPE.	ON	
TEST		NO SETTINGS	-	
TOOL SETTING	CONDITION NO. 1	TOOL CONDITION NO.	CONDITION NO. 1	
		TOOL	PEN	
		SPEED	30	
		FORCE	12	
		ACCELERATION	2	
		CUT LINE PATTERN	OFF	
		TANGENTIAL MODE	OFF	
		OVERCUT (START)	0.000	
		OVERCUT (END)	0.000	
		DISTANCE ADJUST	OFF	
		INITIAL DOWN FORCE	0	
		SET BLADE GROUP	1	
		SET FACTOR	1.0	
	CONDITION NO. 2	TOOL CONDITION NO.	CONDITION NO. 2	
		TOOL	CB09U	
		SPEED/FORCE/ACCELERATION	30//8/2	
		CUT LINE PATTERN	5	
		TANGENTIAL MODE	OFF	
		OVERCUT (START)	0.200	
		OVERCUT (END)	0.200	
		DISTANCE ADJUST	OFF	
		INITIAL DOWN FORCE	0	
		SET BLADE GROUP	2	
		SET FACTOR	1.0	
		CONDITION NO. 3	TOOL CONDITION NO.	CONDITION NO. 3
			TOOL	CB09U
	SPEED/FORCE/ACCELERATION		30//14/2	
	CUT LINE PATTERN		3	
	The range between tangential mode and wear degree (coefficient)is same as Condition 2			
	CONDITION NO. 4	TOOL CONDITION NO.	CONDITION NO. 4	
		TOOL	CB09U	
		SPEED/FORCE/ACCELERATION	20//6/2	
		CUT LINE PATTERN	1	
		The range between tangential mode and wear degree (coefficient)is same as Condition 2		
	CONDITION NO. 5	TOOL CONDITION NO.	CONDITION NO. 5	
		TOOL	CB09U	
		SPEED/FORCE/ACCELERATION	20//8/2	
		CUT LINE PATTERN	4	
		The range between tangential mode and wear degree (coefficient)is same as Condition 2		
	CONDITION NO. 6	TOOL CONDITION NO.	CONDITION NO. 6	
		TOOL	CB15U	
		SPEED/FORCE/ACCELERATION	30//16/2	
		CUT LINE PATTERN	3	
		The range between tangential mode and wear degree (coefficient)is same as Condition 2		
	CONDITION NO. 7	TOOL CONDITION NO.	CONDITION NO. 7	
		TOOL	CB15U	
		SPEED/FORCE/ACCELERATION	20//12/2	
		CUT LINE PATTERN	3	
The range between tangential mode and wear degree (coefficient)is same as Condition 2				
CONDITION NO. 8	TOOL CONDITION NO.	CONDITION NO. 8		
	TOOL	CB09U		
	SPEED/FORCE/ACCELERATION	30//8/2		
	CUT LINE PATTERN	User		
	The range between tangential mode and wear degree (coefficient)is same as Condition 2			

* The initial values of setting items is subject to change.

INDEX

Sign

- ' : ' and ' ; ' Commands 10-5
- 1, 2, 3, 4 key 2-21

A

- Acceleration 2-36
- Accessories 1-2
- AC line inlet 1-4
- Adjusting the Blade Length 2-2
- Adjust the Blade Length Manually 2-37
- ADV 2-24
- Aligning the Push Roller 2-16
- AREA 2-24
- Assembling 1-5
- Attaching a cutter plunger 2-4
- Attaching a pen 2-6
- Automatic Pre Feed 7-4
- Auto media transfer 2-28
- AXIS 2-24
- AXIS Error Messages 12-9

B

- Basket 1-4
- BEEP FOR KEY OPERATION 9-7
- Beep Setting 9-7
- Blade Application and Features 2-3
- Blade Length 2-37
- Blade Wear Detection 6-15

C

- Caution Message 12-12
- CD 1-2
- Change the Cutting Condition (Condition No.) 3-6
- Changing the Hold-down Force 2-18
- Circle-Command Resolution 10-8
- CIRCLE RESOLUTION 10-8
- Cleaning the Cutter Pen 11-4
- COMMAND 10-2
- COMMAND ' : ' , ' ; ' 10-5
- COMMAND 'W' 10-6
- Command Processing 10-2
- COND/TEST key 2-21, 2-25
- Condition No. 3-6
- CONDITION PRIORITY 10-3
- Condition setting 12-13
- Connecting to the Power 2-20
- Connecting with RS-232C 8-3

- Contents of Operation from [COND/TEST] Key 2-25
- Continuously Move Manually 3-3
- Control key 2-21
- Control panel 1-3, 2-21
- Coordinate Axes 5-3
- Copy (Duplicate Cutting) 4-11
- COPY key 2-21
- Cross cut 2-28, 4-18
- CUT DEMO 12-19
- Cut Line Pattern 2-38
- Cutter Blade Manual 1-2
- Cutter blades 1-2
- Cutter holder 1-2, 1-3
- Cutter Plunger 2-2
- Cutter Plunger Exchange 11-5
- Cutter Plunger Nomenclature 2-2
- Cutting 4-2
- Cutting Area 4-2
- Cutting Data 12-17
- Cutting Direction 3-10
- Cutting groove 1-3
- Cutting Out 2-42
- Cutting Test 2-41
- Cutting Width 4-4

D

- Daily Maintenance 11-2
- DATA DUMP 12-18
- Default Screen 2-19, 2-22
- DIAGNOSTICS 12-21
- Display Language 2-19
- Display Language Setting 9-2
- Display Length Unit 9-3
- Display Length Unit Setting 2-52
- Distance Adjust 6-10
- Down Force 6-6

E

- ENTER key 2-21
- Error Messages in GP-GL Command Mode 12-6
- Error Messages in HP-GL Command Mode 12-7
- EXPAND 4-4
- External Dimensions A-4

F

- FAN POWER 9-6
- Fan Suction Setting 9-6

FAST key	2-21
F command	4-19
Feeding Method	2-26
Feed Speed for Pre Feed	7-8
Force	2-35
Force for cross cut	4-20

G

GP-GL Command	10-4
GP-GL STEP SIZE	10-4
Grit roller position guide	1-3, 2-16
Grit rollers	1-3

H

Hold-down Force.	2-18
HP-GL Command	10-7
HP-GL MODEL EMULATED	10-7

I

I/F	2-24
Indicator Lamp	2-22
Initial Blade Control Position Adjust	6-12
Initial Feed.	7-6
Initial Setting	A-11
Interface	8-2
Interface Setting Menu	8-2

L

LANGUAGE SELECTION	9-2
Length of the Page	4-5
LENGTH UNIT.	9-3
Length unit.	2-19, 2-52
Loading Media (Paper or Marking Film)	2-7
Loading Roll Media	2-7
Loading Sheet Media	2-14

M

Manual Position Adjust	5-2
Marking mat.	1-3
MEDIA	2-24
Media.	2-7
Media Change mode is off	4-11
Media Change mode is on	4-14
Media Cutter	1-2
Media flange	1-4
Media guide.	1-2, 1-4
Media guide bar	1-4
MEDIA SENSOR	9-4
Media sensors.	1-3, 9-4
Media set lever	1-3

Media stocker	1-4
Media stopper	1-4
Menu Display.	9-2
Menu Keys.	2-21
MENU lamp	2-22
Menu Screen.	2-24
Menu Tree	A-5
Model ID Response.	10-7
Move Away the Tool Carriage	3-5
Move in Steps Manually	3-3
Move the Tool Carriage and Media	3-3
Moving the Pen While Raised or Lowered in Response to the 'W' Command	10-6

N

Nomenclature	1-3
Normal menu.	2-24
Number of pre feeds	2-46

O

Offset.	2-42
Offset Angle	6-8
OFFSET FORCE.	6-14
Oil-based ballpoint pen	1-2
Oil-based ballpoint pen plunger	1-2
ORIGIN key	2-21
Origin Point	3-7
Origin Point When HP-GL is Set.	3-9
Overcut	6-4

P

Page Length	2-44
Panel Cutting.	4-16
Paper ready time.	4-8
PAUSE/MENU key	2-21
Pause and Resume Cutting	3-12
Pen holder	1-3
Pen station	1-3
Plotter Environment.	9-6
POSITION key.	2-21
Power	2-20
Power cable.	1-2
Power switch	1-4
Pre feeds.	4-7
Printing the Setting of the Plotter	12-13
Priority of Tool Condition Selection.	10-3
Push rollers	1-3, 2-16
PUSH ROLLER SENSOR.	9-5
Push Roller Sensors	9-5

R	
Raise or Lower the Tool	3-2
Reading the Screen	2-22
Ready Screen	2-22
Removing a pen	2-6
Removing the cutter plunger	2-5
Replacing Cutter Blade	11-3
Reset (Revert to the initial state when the power was turned on.)	3-6
Rotate	3-10
RS-232C interface	2-49, 8-2
RS-232C interface connector	1-4
RS-232C interface setting	8-5

S	
Safety Precautions	ii
Screen (LCD)	2-22
Self Diagnostic Test	12-21
SELF TEST	12-15
Sensor	9-4
Separator	8-8
SETUP MANUAL	1-2
SIMPLE key	2-21
SIMPLE lamp	2-22
Simple menu	2-24, 2-43
Sorting the Cutting Data	7-2
Space between tools 1 and 2	6-22
Space rear	4-9
Specifications	A-2
Speed	2-34
Stand	1-2, 1-4
Step Movement Distance	3-4
Step Pass	6-7
Step Size	10-4
Stock shaft	1-4
Stop Cutting	3-12
Storing the Plotter	11-2
Structure of Cutter Plunger	2-2
Supplies	A-3

T	
Tangential Mode	6-2, 6-3
TEST	2-24
Test Pattern	12-15
Timeout	8-11
TO ENSURE SAFE AND CORRECT USE	i, 1-2
Tool	2-4, 2-31
Tool carriage	1-3
Tool Condition	2-29, 2-30
Tool Up Move	7-12

Tool Up Speed	7-10
Troubleshooting	12-2

U	
USB cable	1-2
USB interface	8-2
USB interface connector	1-4
User selection	2-47
User selection setting	8-4

Specifications are subject to change without notice.

CE6000-120AP User's Manual
CE60AP-UM-153
DECEMBER 20, 2013 1st edition

GRAPHTEC CORPORATION

GRAPHTEC