

H. WOODWARD.
ELECTRIC LIGHT.

No. 181,613.

Patented Aug. 29, 1876.

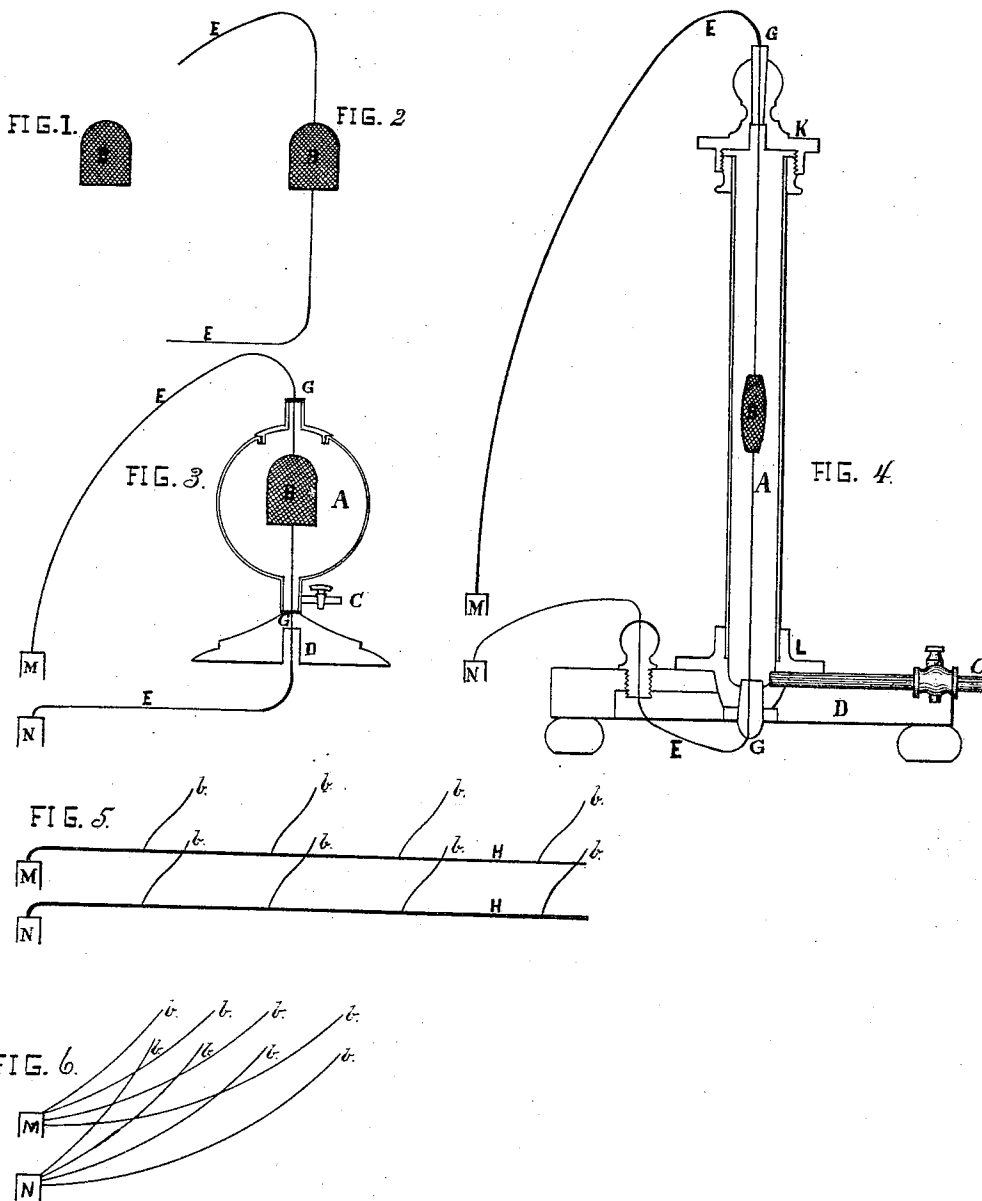

WITNESSES

Geo. T. Smallwood.
John Roby.

INVENTOR

Henry Woodward.
By *John J. Halsted*
Attorney

UNITED STATES PATENT OFFICE.

HENRY WOODWARD, OF TORONTO, ONTARIO, ASSIGNOR, BY MESNE ASSIGNMENTS, TO RUPERT MEARSE WELLS, THOMAS RICHARD FULLER, AND ERNEST HEIMROD, OF SAME PLACE, AND CHARLES H. WOODWARD, OF LINDSAY, CANADA.

IMPROVEMENT IN ELECTRIC LIGHTS.

Specification forming part of Letters Patent No. 181,613, dated August 29, 1876; application filed January 4, 1875.

To all whom it may concern :

Be it known that I, HENRY WOODWARD, of the city of Toronto, county of York, in the Province of Ontario, Canada, have invented new and useful improvements in the art or process of obtaining artificial light by means of electricity; and I do hereby declare that the following, taken in connection with the drawings which accompany and form part of this specification is a description of my invention sufficient to enable those skilled in the art to practice it.

In the first place, I use a gas-engine or other suitable motive power, for the purpose of rotating a magneto-electric machine, and at such a velocity as shall create electricity sufficient to heat certain pieces of carbon hereinafter described. The magneto-electric machine should be of sufficient power for the purpose of heating the carbon to a state of incandescence. A piece of carbon of suitable size is scraped and shaped until fitted for the purpose; one pole is then attached to the top of the carbon, and the other to the bottom thereof, by suitable electrodes. It is then inclosed in a globe or other vessel, either of glass or other suitable material. The air is then exhausted from the said globe or vessel after it has been hermetically sealed at the ends, and the globe is then filled with a rarefied gas that will not unite chemically with the carbon when hot. Electricity is now supplied, and in sufficient quantity to heat the carbon within the vessel to a state of incandescence. The rarefied gas previously introduced now becomes luminous, and constitutes the light herein designated as "Woodward's electric light."

This arrangement and process will give a light of any required intensity, and there is, practically, no limit to the number of lights that may be obtained from one magneto-electric machine.

In the accompanying drawings, the same letters of reference indicate the same parts

in all the views, and also in this specification.

Figure 1 is an elevation or front view of a piece of carbon, and is marked B. It is supposed to be scraped and shaped until suitable for the required purpose.

Fig. 2 is also an elevation or front view of a piece of carbon with the electrodes E E attached thereto, leading to and from the positive and negative poles of the battery, one being attached at the top and the other at the bottom of the carbon.

Fig. 3 is a sectional elevation, showing a globe marked A, but which may be a vessel of any other suitable form. The prepared carbon B is also shown therein, with the aforesaid electrodes E E attached thereto; showing, also, a tube, C, with an air-tight stop-cock, to be used in exhausting the air from the globe A, and for the injection of rarefied gas into the same; showing, also, the hermetical sealing of said vessel at the ends G G of the tubes, and showing, also, the stand D.

Fig. 4 is a sectional elevation, showing the adaptation of another form of vessel, A. This drawing is on a larger scale, in order to show the manner of closing the ends of the vessel, which is done by brass sockets, that at the top being marked K, and that at the bottom being marked L; showing, also, a carbon, B, different in form from that in the other vessel, and having the two electrodes E E running to and from the poles N and M.

Fig. 5 is an elevation, showing one mode of connecting the various lights with the machine by means of two trunk-wires or electrodes, H H, running from the positive and negative poles M and N of the machine, with branches *b b*, &c., therefrom, to each light.

Fig. 6 is also an elevation, showing another method of connecting the lights with the machine, each light having a distinct wire, *b*,

running to each pole M N of the machine or battery.

Having thus described my invention, I claim—

A carbon, B, in combination with a lamp or other suitable vessel, A, filled with rarefied gas, possessing the property of not chemically combining with the carbon when in a

state of incandescence, in connection with the described arrangement and mode of connection of the electrodes E E with the carbon, all as shown and set forth.

HENRY WOODWARD.

Witnesses:

WILLIAM FITCH,
GEO. T. SMALLWOOD.