

Curtice Brothers – The Pepsi-Cola of Catsup Packers

Bill Lockhart, Bob Brown, Beau Schriever, and Bill Lindsey
with Contributions from John Lord and Barry Bernas

Although the Curtice Brothers were best known for their canned vegetables and fruits (as well as ketchup), their bottles are of more interest to archaeologists and collectors. Like the Pepsi-Cola Co., always second to the powerful Coca-Cola Bottling Co., the Curtice Brothers always played second to H.J. Heinz. Both firms therefore became the innovators. Where Pepsi had the brilliant idea of selling 12-oz. bottles of their drink at the same price as the 6-oz. bottle of Coca-Cola, Edward N. Curtice patented a new and distinctive ketchup bottle. The Curtices seem to have been early adopters, probably being the first to try out two catsup bottle finishes, one of which became the industry standard.

Between 1876 and the mid-1920s, their ribbed, patented bottles were distinctive both for the unusual design and for the manufacturer's marks on their bases. Many of these glass house logos are unique, never found on other bottle types, and several others were the first ones used by specific glass houses – including the Owens Bottle Machine Co. Although the Curtice Brothers outlived its founders and went through later changes, our interest ceased in 1925, when the firm adopted generic bottles with paper labels as their only way to identify the company.

History

About 1862, Simon G. Curtice opened a small grocery store in the Flatiron building at the corner of Main North and Franklin Streets at Rochester, New York. His brother, Edgar N. Curtice, joined him in the business in 1865, and the two began canning the excess produce from the store. Three years later (1868), the canning business had prospered to the point where they moved to the corner of Water and Mortimer Streets, dropping the retail grocery trade to concentrate on canning (Peck 1908:646; Zumwalt 1980:102).

The business had grown so much by 1872 that the brothers built a new plant at 200 N. Water St. and expanded in 1880. They incorporated the Curtice Brothers Co. in 1887, with a capital of \$200,000. Simeon was president, with Edgar as vice president and treasurer – Robert

A. Badger as secretary. On February 10, 1893, the company became the Curtice-Olney Co., but it reverted to the Curtice Canning Co. the following year. With the merger, the Curtice brothers acquired the Woodstown, New Jersey, plant of the former Olney firm and also added a plant at Vernon, New York, about the same time or earlier. The firm reorganized in 1901 as the Curtice Brothers Co. with the same officers, raising the capital to \$1,500,000 – a seven-fold increase in just 14 years (Peck 1908:646; *Rochester Democrat and Chronicle* 7/1/1901).

Upon Simeon’s death in 1905, Edgar assumed the presidency (while retaining the treasurer position), while Henry B. McKay became vice president. Badger remained as secretary. As an interesting aside, the 1906 Pure Food & Drug Act required the listing of ingredients on the labels of food products, and Heinz used the Curtice disclosure of sodium benzoate to manipulate the public into questioning the safety of Blue Label Ketchup.

The firm opened a plant at Corydon, Indiana (near Louisville, Kentucky), in 1919 but closed it in 1923. When Edgar died in 1920, the Security Trust Co. assumed control, soon to sell out to Douglas C. Townson. Townson almost immediately introduced a wide-mouth ketchup bottle – announced on October 30, 1920, in the *Syracuse Herald* (Peck 1908:646; Zumwalt 1980:103 – Figure 1). In 1961, Curtice Brothers merged with C.F. Burns & Son to form Curtice-Burns Foods. Curtice-Burns Foods, Inc. remains in business in 2022.



Figure 1 – 1920 ad (*Syracuse Herald* 10/9/1920)

A Note on Terminology

The earliest term for the condiment made from mashed tomatoes was ketchup. Originally a British word, it derived from the Chinese *kê-tsiap*, a sauce made from fermented fish. It is probable that British explorers or colonists discovered the sauce in Southeast Asia, attempted to reconstruct it from tomatoes, and Anglicized the word to ketchup (Wiggins 2014). Jonathan Swift coined the word “catsup” in 1730, and that spelling became the norm in the U.S. until major packers like Heinz and the Curtice Brothers labeled their products “Ketchup” (Hill 2010).

Table 1 – Timeline for Curtice Brothers

Date	Event
1862	Simon Curtice opened a grocery store
1868	Curtice Brothers dropped retail sales for full-time wholesale canning
1887	Incorporated as Curtice Brothers Co.
1893	Became Curtice-Olney, acquiring Woodstown, NJ, plant
1894	Became Curtice Canning Co.
1901	Reorganied as Curtice Brothers Co.
1919	Opened Corydon, Indiana, plant
1920	Edgar died; Security Trust Co. took over & sold business to Douglas C. Townson; adopted wide-mouth ketchup bottle
1923	Closed Corydon, Indiana, plant
1961	Merger created Curtice-Burns Foods, Inc.

Oddly, there was a disconnect between the packers and the glass houses on terminology. Many of the larger packing firms consistently used the term “ketchup” – but the glass industry equally consistently preferred “catsup” – as shown in existing catalogs. Because our focus is on glass containers, we have preferred the “catsup” spelling, but we have primarily used “ketchup” in this study, honoring the term used by the Curtice Brothers. However, both terms have the same meaning, so we have used them interchangeably.

A Capsule History of Catsup (or Ketchup) Bottles

While the term “ketchup” appeared as early as 1682, we have no information about its packaging in glass containers until an ad in the *Philadelphia Gazette* for June 12, 1766, informed the public that Samuel Frauncis [actually Fraunces] had a large variety of food for sale, including “Ketchup in Bottles.” Of course, we have no clue as to what type of bottles. However, by the 1840s, ketchup was bottled in peppersauce bottles, and, by 1856, some ketchups were in eight-paneled bottles (with bulging panels; not flat or fluted like later).

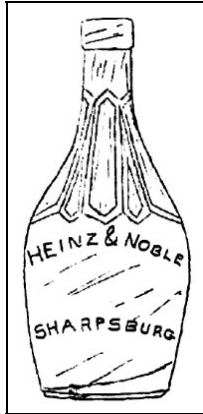

Figure 2 – Heinz & Noble bottle (Eastin 1965:35)

The Heinz & Noble Co., Sharpsburg, PA (1872-1875), used a bulbous ketchup bottle (Figure 2), and similar bottles – with a bulbous body, double ring finish, and fluted shoulder style were firmly considered to be ketchup bottles by the mid-1870s, possibly following the leadership of Heinz & Noble – although the Curtice Brothers used a bulbous bottle embossed with their name prior to their 1876-patented bottle. So, who followed whom? According to Eastin (1965:35), Heinz used a variety of bottles between 1880 and 1910, often of the bulbous variety (Figure 3).

On October, 1876, E.N. Curtice applied for a patent for the “Manufacture of Bottles” – with a drawing of what became the initial embossed Curtice ketchup bottle – and received Patent No. 184,593 on November 21 of the same year. The drawing showed tiny vertical ribs all around body (a “corrugated” body to provide a more secure grip) with an unembossed circle in

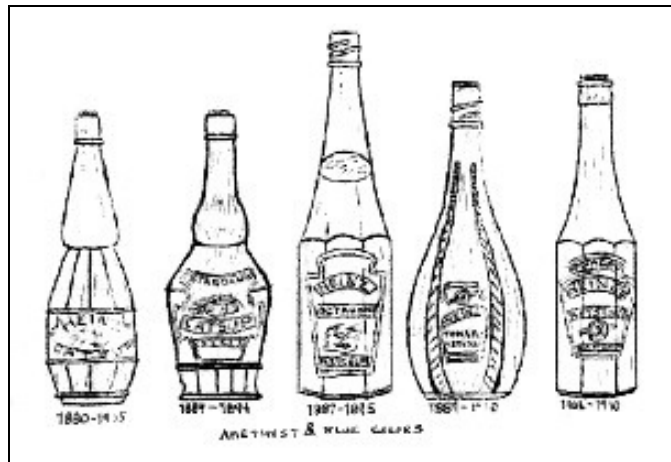

Figure 3 – Heinz bottles (Eastin 1965:35)

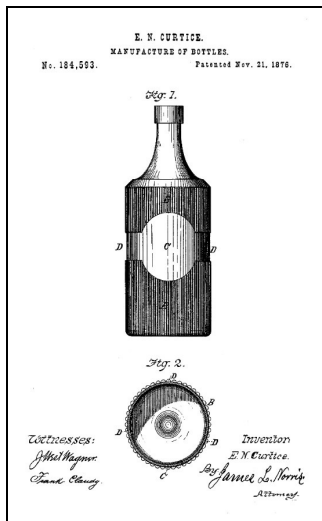

Figure 4 – 1876 E.N. Curtice patent

the center for paper label (Figure 4). The firm probably adopted the style very soon, and it continued to use the vertical ribs on bottles until it joined the trend toward generic bottles with paper labels, apparently phasing the large-mouth, generic bottles into use in 1920 and completing the transition in 1925.

Although Eastin (1965:35) illustrated what became the standard for the catsup bottle – paneled body, continuous-thread finish (see Figure 3) – and dated the bottles 1887-1915 – it is unclear as to whether Heinz actually used such a bottle that early. The Heinz bottle referenced by Eastin was actually patented in 1890. H.J. Heinz applied for a patent for a “Design for a Bottle” on May 20, 1890, and received Design Patent No. 19,911 on June 17 of the

same year (Figure 5). Heinz described the major features of his design as a “series of flat faces or panels . . . extending from the bottom of the bottle to almost its middle and having their side edges vertical and parallel, and the converging edges or sides . . . tapering up from the upward end of the flat panel representations.” Although he made no claim for the number of faces or panels, this was clearly the octagonal container that became *the* prototype for catsup bottles. Neither Hienz nor Curtice made any claims about the continuous-thread finish (see the section on finishes and paper labels below).

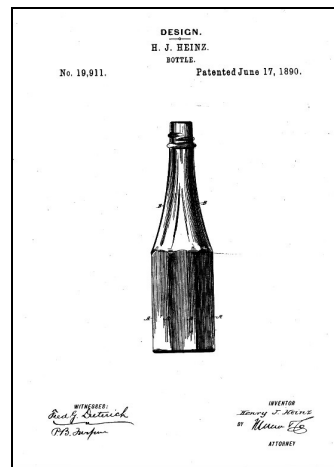

Figure 5 – Heinz 1890 patent

The British Ashley machines – generally called Johnny Bull or United machines in the U.S. – made ketchup bottles in a few American factories by at least 1909, possibly earlier. These were semiautomatic machines, and they were never very popular because of problems during use. As early as 1905, some U.S. glass houses began experimenting with narrow-mouth, semiautomatic bottle machines, but few were practical until ca. 1910 or later. Machine manufacture of catsup bottles did not become the norm until the 1914 invention of gob feeders that turned semiautomatics into full automatic production. However, Plant No. 3 of the Owens Bottle Machine Co., Fairmont, West Virginia, made catsup bottles for the first time on an Owens Automatic Bottle machine by at least July of 1911. Mouth-blown catsup bottles became a thing of the past (Glass Bottle Blowers’ Assn. 1911).

Bottles

From 1868 until the early 1870s, the Curtice Brothers may have used generic ketchup bottles with paper labels as the only identification, although we have discovered a single example of a bulbous bottle that predated the 1876 patent – by how long, we cannot tell. In 1876, or shortly thereafter, the firm used bottles made to fit the Edgar Curtice 1876 patent (described above) and continued their use until at least 1885, probably until 1887. When the brothers incorporated as the Curtice Brothers Co. in 1887, they almost certainly adopted the more narrow bottles with elongated neck-shoulder areas embossed with a medallion containing the



Figure 6 – 3 sizes (eBay)

company name and location (see a more thorough bottle description below). The bottles appear to have been made in three sizes – quart, pint, and half-pint – as well as a tiny 4¼" tall sample bottle, holding two ounces of ketchup and one a 4¾" tall that held an extra ounce (Figures 6 & 7). See below for a description of the sample sizes.



Figure 7 – Regular & sample (eBay)

From the time the Curtice Brothers patented their own ketchup bottle design in 1876 until they switched to a flat-paneled bottle identified only by a paper label between 1920 and 1925, the firm passed through three major changes in embossing of the bottle design, a major shift in finish style, and the move from mouth-blown to machine-made bottles. In addition, the brothers were the first in the packer trade to require their suppliers to emboss their initials or logos on bottle bases in 1901, a practice that had already become commonplace on returnable beer and soft drink bottles. As a result, their suppliers – most of which did not use logos on their glassware – produced unique manufacturer's marks during the 1901-1911 period. The study of these bottles is best divided into six temporal periods:

- A) 1868-1876 – bulbous bottles with cork finishes, possibly generic bottles
- B) 1876-1887 – mouth-blown bottles with finishes for corks and no basal embossing
- C) 1887-1901 – mouth-blown bottles with continuous-thread finishes and numbers on bases
- D) 1901-1914 – mouth-blown bottles with continuous-thread finishes and basal logos
- E) 1914-1925 – machine-made bottles
- F) 1920-? – paneled, wide-mouth bottles

A) 1868-1876 – Early Curtice Brothers Bottles

With our current knowledge, this period is difficult to define. The first news we have discovered for Curtice Brothers Ketchup was an ad from H.H. Lee in the *Indianapolis News* of October 15, 1880. Lee had “Received 25 Case Quarts, 25 Cases Pints, Curtice Brothers Celebrated New Tomato Ketchup.” However, there was no reason for Edgar N. Curtice to have patented a ketchup bottle in 1876, if the brothers were not already selling ketchup, so Curtice certainly bottle catsup by the mid-1870s. However, we do not know when Curtice actually began packing catsup. From the beginning, its primary products were in cans.

But, we have one piece of evidence. Some years ago, an eBay seller posted a photo of a bulbous catsup bottle embossed “CURTICE BROTHERS (arch) / CB monogram / ROCHESTER, N.Y. (horizontal)” on the flat front face of the body (Figures 8 & 9). The bottle was only nine inches tall, 3.5 inches wide, and had four embossed ribs on the sides – a preview of the 1876 ribbed bottle. The seller noted that the bottle had “an iron pontil mark.”



Figure 8 – Bulbous bottle (eBay)

The use of this bottle was clearly during the years prior to the adoption of the ribbed bottle patented by Edgar N. Curtice in 1876. Such bottles were used for catsup at least as early as the Heinz & Noble period, 1872-1875. As noted above, Curtice and Heinz were vying with each other for top position in catsup sales as well as bottle designs.

So, we can hypothesize that the Curtice brothers used the bulbous design during the early 1870s, possibly earlier. If the brothers bottled ketchup prior to the time, they likely used generic peppersauce bottles only identified by paper labels. Short of finding newspaper advertising or some other form of historical reference, we cannot say with any certainty that the brothers packed catsup any earlier. The firm’s primary products were canned fruits and vegetables, although some were packed in jars. A bottling line required a completely separate arrangement.



Figure 9 – Bulbous label (eBay)

B) 1876-1887 – mouth-blown bottles, cork finishes, no basal embossing

Although the design is described in greater detail below, the initial Curtice Brothers ketchup bottle was wider and shorter than the later style, with “CURTICE BROTHERS PATENTED” around the shoulders, embossed vertical ribs on the body, and a one-part finish to be sealed by a cork (Figures 10 & 11). Oddly, some of the bottles were made by three-piece molds plus a baseplate – i.e., three parts to form the body of the bottle – and had a two-part



Figure 10 – 1876 bottle - 3-piece mold

finish, a smaller ring below a thicker collar (Figures 12 & 13). The three-piece molds were probably the earlier of the two methods.

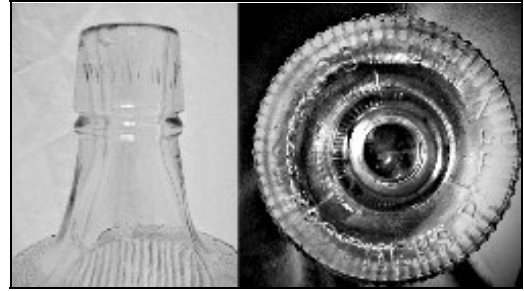

Figure 11 – Shoulder and finish

Although the opening date for this section is intuitively obvious – the Edgar N. Curtice patent of 1876 – the date at the end needs some discussion (see Figure 4). When the Curtice Brothers reorganized in 1887, one of the main changes was the adoption of Blue Label branding. Even though the firm did not apply for the Blue Label trademark until March 2, 1906, it claimed a first use of the logo in June of 1887. The new catsup bottles (see next section below) were made to fit the rectangular Blue Label paper sticker.



Figure 12 – 1876 bottle - 2-piece mold (eBay)



Figure 13 – Shoulder (eBay)

That would be pretty straight forward if the Blue Label brand were restricted to catsup. However, the Curtice Brothers used the name for a large variety of canned produce as well. Although collectors offered clipped ads for sale that showed the newer Blue

Label bottles, claimed to be from 1888 and 1889, those dates were unsupported – no citation as to where they came from – and they looked like ads from the mid-1890s. The earliest ad we could find was from 1891 and looked quite different (Figures 14 & 15).

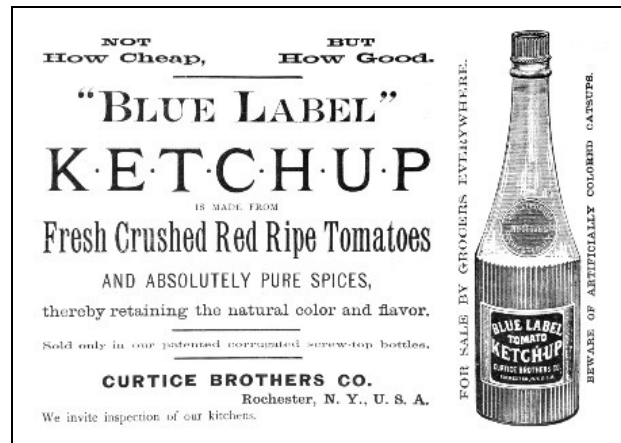

Figure 14 – “1888” ad (eBay)

However, Simeon G. Curtice received a patent for a “Top for Cans, Jars, &c.” on September 28, 1888 – although the drawing makes it clear that this became the design for aluminum caps for ketchup bottles. The design was for the ribs to form a grip for cap removal – *not* for the aluminum or screw threads. There would be no reason to design the cap if the bottle did not already exist, so it is virtually certain that the Curtice Brothers adopted the screw-top bottle in 1887. See the section below on Paper Labels and Caps for more details about the patent.

C) 1887-1901 – mouth-blown bottles, screw-tops, numbers on bases



Figure 15 – Pittsburgh Dispatch ad (Feb. 9, 1891)



Figure 16 – Tall bottle & Medallion

These bottles retained the vertical ribs and had what became the typical tall, shoulder/neck section on ketchup bottles as well as the earliest continuous-thread finishes on ketchup containers (Figures 16 & 17). These may



Figure 17 – Continuous-thread finish



Figure 18 – Numbered base (eBay)

have been used during the first half of this decade-long period. Each bottle had a medallion at the neck/shoulder area embossed “CURTICE BROTHERS CO” in an arch, “PRESERVERS” horizontally, and “ROCHESTER, N.Y.” in an inverted arch. Although a few bases were unmarked, most were embossed with a three- or four-digit number, usually horizontal at the center (Figure 18). There were too many numbers to have been model codes for the different sizes of containers, and some seem to have been sequential, so each new

run of bottles may have received a new number. On at least one base in our small sample the last digit appears as if it *may* have been altered.

Until 1893, the Curtice Brothers ketchup production was still contained in this small section of New York, so all of the bottles probably were still manufactured by the Rochester Glass Works. However, the firm reorganized as the Curtice-Olney Co. in 1893, acquiring a factory at Woodstown, New Jersey, that already bottled catsup. Although the name became the Curtice Canning Co. the following year, the acquisition remained, so the firm now had two catsup production centers. At that point, Curtice may have shifted its bottle purchases to a wider range, expanding farther afield during the latter part of the period. The number of bottle producers certainly had increased by the early part of the next period. When the firm again reorganized in 1901, it reverted to the Curtice Brothers Co., very likely the point for the next bottle change.

D) 1901-1911 – mouth-blown bottles, screw-tops, basal logos

With the 1901 reorganization, the Curtice Brothers adopted their requirement that each bottle maker emboss its initials or logo on the base of every bottle sold to them. This demand was almost certainly for quality control, and the practice suggests that the firm may have had some issues with bottle quality from early suppliers. Although the Curtice Brothers purchased bottles from at least 11 different glass houses during this 14-year span, we have found two logos at online auctions more frequently than any others: BB and BBGCo, probably both logos used by the Berney-Bond Glass Co. Apparently, the Curtice Brothers required a different set of initials for each *factory* – not just each glass company. This was also apparent later (section E – below) with the T (Toledo) and F (Fairmont) initials on bottles made by the Owens Bottle Machine Co.

It is virtually certain that all of the eleven suppliers (at least) of mouth-blown bottles adopted the marks they used in order to satisfy the Curtice Brothers requirement, some of them (e.g., CGCo, JGCo, JH, HA, and R) never to be found again on glass products. The Rochester Glass Works (using marks of “F.E.R.&Co.” then “F.E.R.G.Co.”) continued to use logos on some of its products from that time on, and the Hazel Glass Co. added an “H” to a few of its jars after that. The Illinois Glass Co. had used its “I.G.Co.” initials on returnable beer and soda bottles, so it just transferred its usual mark to the catsup bottles. It was not until much later that the

Berney-Bond Glass Co. returned to “BBGCo” and “BB” marks (specializing in milk bottles by that time and adding its “48” identifier). Several of these glass houses were open during the entire 14- year span for these bottles, but there seems to have been no sequential use of each glass house. Apparently, Curtice Brothers either took advantage of various sales or bought from all of them according to need. The most common bottles we have found from this period on eBay had “BB,” “B.B.,” or “B.B.G.CO.” basemarks.

E) 1911-1925 – Owens machine-made bottles

In 1909, several U.S. glass houses installed British Ashley semiautomatic machines (also called United or “Johnny Bull” machines), and the Hazelhurst factory of the Berney-Bond Glass Co. used at least one of these to make catsup bottles – although Berney-Bond removed the four machines the following year. Meanwhile, other American glass firms had begun experimenting with various forms of semiautomatic machine to make small-mouth ware in 1905, spurred by the success of the Owens machines – patenting several by the 1910-1911 period (Figure 19). However, the Curtice Brothers only seem to have partaken from one of these non-Owens machines (see below).



Figure 19 – Owens base scar & machine finish

It seems obvious that once the brothers tried ketchup containers from Owens Bottle’s Fairmont, West Virginia, plant, the contract landed there exclusively. Aside from a test bottle (see “T” in the Manufacturer’s Mark section), the earliest of these were marked with a small letter “F” plus the Owens scar, and most of these did not include the arc of dots surrounding the letter and a date code that were found on bottles made from 1917 to 1919, suggesting that many of the bottles were made at least as early as 1911, when the Fairmont plant began making ketchup bottles (possibly adding catsups to the line just to accommodate the Curtice Brothers contract). When Owens reorganized in 1919, the firm adopted the Square-O logo, signifying a square deal, adding date codes in 1920. We have found date codes from 1920 to 1925 on the Square-O bottles as well as a few without date codes (from 1919).

Zumwalt (1980:101) suggested that the typical Curtice embossed, small-mouth bottle was used until the 1920s, and that was confirmed by ads that continued to show the same bottle style until at least 1925 – the last ad we found – as well as the latest date code we have discovered on one of the embossed bottles. However, an advertisement in the October 9, 1920, *Syracuse Herald* introduced a “New Wide-Mouth Bottle” – multi-paneled with no embossing and a paper label on the neck (see Figure 1). There seems to have been a transitional period from 1920 to 1925, when the firm offered both bottle styles. The entire trend to Owens bottles probably began slightly earlier, when Plant No. 2 at Toledo, Ohio, made what was probably a trial bottle to be used in a test market by the Curtice Brothers. See a more complete discussion in the Owens section below.

F) 1920-? – large-mouth bottles with fluted sides

In 1920, the Curtice Brothers announced the introduction of their new large-mouth bottle. These were conical in shape with fluted sides and a rounded neck-shoulder area for the label. The only example we have seen was embossed “BLUE / LABEL / KETCHUP / 3 {Diamond-OI logo} 3” – made at Plant No. 3 in 1933 (Figure 20; also see Figure 1). Since these bottles are beyond the scope of this project, we do not know how long they were made. Although Curtice introduced the new bottles in 1920, the full adoption was a process, finally complete in 1925, when the firm phased out the final production run of ribbed bottles.



Figure 20 – Large-mouth base (eBay)

Sample Bottles

By at least October 28, 1897 (*Buffalo Commercial*), the Curtice Brothers were giving away sample bottles of catsup – in this case, with the purchase of a dollar’s worth of goods. Similar promotions with the same bottles continued until at least 1926, possibly later. These tiny bottles were 4¼"



Figure 21 – Sample bottles (eBay)

tall and held two ounces of Blue Label Ketchup – although less common were slightly larger bottles – 4¾" adding an extra ounce. At least one of the taller bottles had a crown finish (Figure 21; also see Figure 7). The overall design was the same as the larger ketchup containers, including the vertical ribs and a tiny label. The medallion, however, only enclosed a CBCO monogram, lacking the company name and location indicated on the larger bottles (Figure 22). The bottles made the transition from mouth-blown to machine production, some having no basemarks, some numbers, and at least “JH” and “F” logos.



Figure 22 – Medallion (eBay)

Mouth Blown

Prior to the invention of narrow-mouth bottle machines, all catsup bottles were mouth blown into a two-piece mold, the finish then created by hand. All of the early catsup bottles were topped by a one- or two-part finish, sealed with a cork, including the earliest bottles used by the Curtice Brothers. Edgar N. Curtice applied for a patent for the “Manufacture of Bottles” on October 21, 1876, and received Patent No. 184,593 on November 21 of that year (see Figure 4). He described his bottle as relating to:

certain improvements in the construction of bottles for liquors and other materials, and is designed particularly for tomato and other catchups [*sic*] or condiments, its object being to give the bottle an ornamental exterior surface, which will, at the same time, enable it to be more readily grasped and held by the hand when being used, and also to provide for convenient attachment of the labels to the same, so as not to be injured by the handling of the bottle, or by packing or transportation of the same.

My invention consists in a bottle having ribs or corrugations extending from its bottom edge to its shoulder, said ribs or corrugations being intercepted at about the center of the bottle by an annular recess encircling the bottle, the said annular-recess being intercepted by one or more circular recesses forming seats for a label (see Figure 4).

Although this description did not include the various designs that graced the later bottles, it clearly defined the vertical ribs of the Curtice Brothers bottles and the bare labeling area. The original patent drawing did not include the continuous-thread finish, and this was probably added in 1887 – possibly the first time finishes for screw caps were ever used on ketchup bottles (as noted above). The earliest bottles looked just like the patent drawing, with the addition of “CURTICE BROTHERS PATENTED” embossed on the shoulders (see Figures 10-13). As noted above, some of the bottles were made in three-piece molds. See discussions below for more details.

In 1887, the brothers modified the design, retaining the vertical ribs on a much trimmer bottle with a rectangular area for a paper label and an embossed medallion on the shoulder encircling the company name, location, and “PRESERVERS” (see Figure 16). Some of the bases were unembossed, but many were made with four-digit numbers, ranging from 1616 to 1653 in our sample; often, these were double stamped (see Figure 18).

The taller mouth-blown bottles were all topped with continuous-thread finishes. These were what Lindsey (2022) called “improved-tooled finishes.” Unlike the typical mouth-blown methods, the molds for these bottles made the entire finish (Figure 23). When the bottle was removed from the mold, it was held in a special tool, then the bottle was wetted or broken off of the blowpipe. The end was then tooled to make it even across the top and usually fire polished (Figure 24). Once the bottle was filled, it was sealed with an aluminum screw cap.



Figure 23 – Mouth blown finish (eBay)



Figure 24 – Fire Polished (eBay)

Continuous Threads and Aluminum Screw Caps

As noted above, continuous-thread finishes were not new, only adapted to catsup bottles (see Figure 23). Originally patented in 1858 for Mason fruit jars, these had been adopted for use on small-mouth liquor flasks by the mid-1870s using the same manufacturing technique as the earlier jars. The Curtice Brothers were probably the first to adapt the threads to catsup bottles,

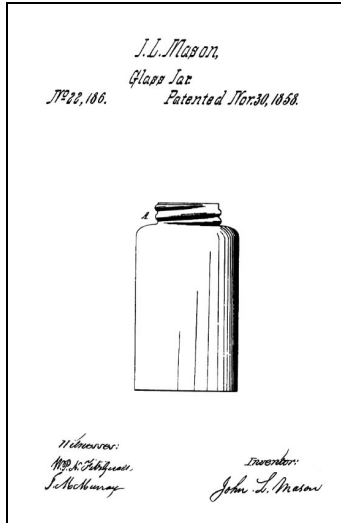

Figure 25 – Mason 1858 patent

although they may have borrowed the idea from Heinz. Both firms used bottles with continuous-thread finishes about the same time, but we have no record of the exact date because the technique could not receive a new patent.



Figure 26 – Ground Rim flask (eBay)

A similar patenting problem occurred with the aluminum caps. Mason patented a screw lid in 1857, although the material (aluminum, steel, etc.) was irrelevant to the patent (Figure 25). Again, aluminum caps were pioneered by the liquor trade during the mid-1870s (Figure 26). However, Simeon G. Curtice applied for a patent for a “Design for a Top for Cans, Jars, &c.” on July 2, 1888, and received Design Patent No.

18,622 on September 25 of that year. His design was for “a series of concave indentures of uniform size in the upper edge of the top, extending around the entire circumference, and entirely inclosed in the general outline of the top” – i.e.,

notches at the top of the cap, although it also showed vertical ribs (similar to the ones on the bottle) to facilitate gripping the caps for opening and closing (Figure 27). Curtice also noted the “raised screw thread on the cap” – although he did not claim it as an integral part of the design.

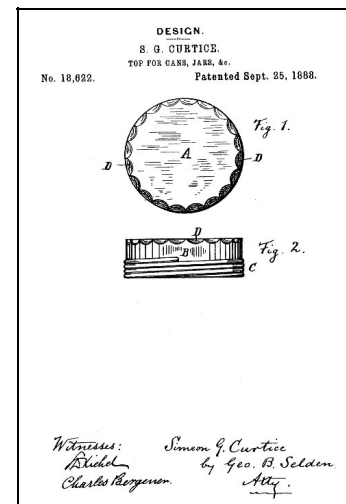

Figure 27 – Curtice 1888 patent



Figure 28 – Ribbed cap (eBay)

In addition, Curtice claimed that “the design may be further ornamented by a circular boss on the upper surface of the top, located at the center thereto.” All of the actual caps we have found had the “boss” on the top – although they were made with and without ribs. The variation that included the ribs was embossed on the top with “CURTICE BROTHERS CO. (arch) / ROCHESTER,

N.Y. (inverted arch) in an outer ring, “PATENTED (arch) / SEP 25TH 88 (inverted arch) in the outer ring, and a large dot in the center (Figure 28). Caps without the ribs had the company name and location and the dot but not the patent information (Figure 29).

Both Curtice Brothers and Heinz advertised bottles with continuous threads and screw caps in the same year – 1891 – at least once on the same page of the same magazine (see Figure 15). Each bottle had what was obviously a screw cap, although each had a different design. Heinz bragged about its “New Octagon Shape” – pretty surely an attempt to create a gripping surface in competition with the Curtice “corrugated” gripper.



Figure 29 – Plain cap (eBay)

The Heinz bottle also had a protrusion on top, obviously referencing the Hahn 1890 patent. George W. Hahn applied for a patent for a “Design for a Bottle Cap” on April 7, 1890, and received Design Patent No. 19,835 on May 13 of the same year (see Figure 5). The cap had screw threads, vertical ribs, and a protrusion on top – obviously the cap shown on the 1891 ad and again in the following year (see Figure 15). However, Heinz ads had no illustrations in 1893, and the top protrusion had disappeared from the 1894 ad – although the cap retained the ribs.

When Hahn said, “with an externally projecting spiral rib 4 which forms an essential feature of the design” – and the drawing showed that to be the screw thread – the patent essentially just claimed the threads as part of it. There is no doubt that this was the cap on the 1891 and 1892 drawings (see Figure 15). The ribs on the side of the cap were a pretty obvious attempt to discredit the ribs on the Curtice caps – in use since at least 1888, probably 1887. The protrusion on the top was a way to make the cap sufficiently unique to pass the patent testing. The Curtice brothers may have sued Heinz over the patent. That might explain the withdrawal of the cap by at least 1894.

We have been unable to determine just how these aluminum caps were formed. There was little uniformity with threaded, mouth-blown bottles. A look at actual caps and finishes shows that they apparently sealed on a sealing ring at the base of the finish – not on the rim (see

Figures 28 & 29). However, each finish was made to a slightly different height because of the methods available. This was one of the reasons why the continuous threads did not reach other markets prior to the mid-1920s, when small-mouth machine-made bottles standardized the cap sizes. Catsup was a thick semi-liquid that did not require a perfect seal. All of the mouth-blown Curtice finishes we have seen were fire polished to make the rim smooth, although that would have made better sense with a top or rim seal (see Figure 24). Perhaps the purpose was for cleanliness; a broken off or ground rim would have been unsightly to say the least as well as collecting particles of catsup.

Machine Made

Aside from the typical machine characteristics (especially machine scar on the bottle base and a horizontal seam at base of finish), the machine-made bottles were identical to the earlier mouth-blown ones. However, some bottles with “F” logos and all all with Square-O basemarks had a large slot in the base, used to line up the bottle while a label was added, and a combination finish to accept multiple closures. See the Later Finishes section (below) for details.

As noted above, the British Ashley Machine was actually patented in 1886 but saw little use in the United States and was first listed as making catsup bottles in 1909. American semiautomatic bottle machines were making small-mouth bottles by 1910, but the production of catsup bottles was not common by machine until ca. 1914 – although the Owens Machine Bottle Co. plant at Fairmont, West Virginia, began producing catsup bottles on the Owens machines by 1911. We have found no indication that any other Owens plant manufactured catsups until later.

Later Finishes

About 1917, either the Owens Bottle Machine Co. or the Hazel-Atlas Glass Co. developed the three-part combination finish for catsup bottles (Figure 30). The top sealing ring was virtually identical to those found on a crown finish, while the second part was taller and rounded, with a single continuous thread wound around once, and the final



Figure 30 – Combination finish (eBay)

reinforcing ring was similar to the top ring. This combination finish could take crown, Goldy, or screw caps.

Owens used one of these finishes on a Curtice Brothers ketchup bottle prior to the adoption of date codes in mid-1917. However, these are very rare in comparison with regular screw caps and continuous-thread finishes on the early bottles with the “F” logo from the Fairmont plant. Therefore, the new finish probably appeared in late 1916 or early 1917 and was used on Curtice bottles made by Owens until the last date code we have found – 1925.

In addition, we have discovered a single Curtice bottle with the combination finish and “HA” embossed on the base – the only machine-made “HA” bottle in our small sample of three with that mark. The other two were mouth blown with continuous-thread finishes. We have attributed the “HA” logo to Hazel-Atlas, a known maker of catsup bottles with 15 varieties of such containers in the 1908 catalog, almost all with continuous-thread finishes (Figure 31). This bottle is discussed further in the “HA” heading of the Manufacturer’s Marks section (below).

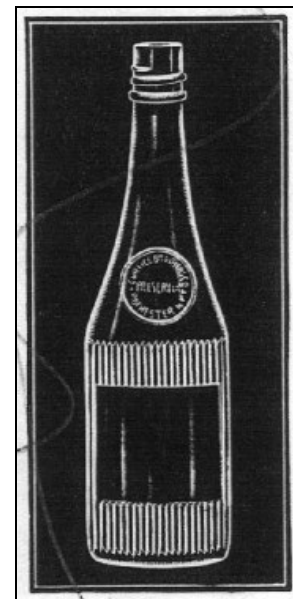

Figure 31 – Hazel-Atlas 1908 catalog

Sloted Bases

As noted above, Curtice catsup bottles had a debossed slot on each base during the 1917-1925 period. The slots were rectangular when viewed from the base, a half-inch long, a quarter-inch wide, and a quarter-inch in depth on a 12-ounce bottle. Viewed with the bottle sitting on a table, the slot was rounded, about a half-inch deep at the center, as if to fit the edge of a large, fat coin (Figure 32). Although we have not found the exact patent that had to have been applied for by at least 1917, a 1927 patent illustrated and discussed the use of such slots.



Figure 32 – Slotted base (eBay)

Charles H. Oslund and John E. Johnson applied for a patent for a “Spotting and Labeling Machine” on January 10, 1925 and received Patent No. 1,641,045 on August 30, 1927 (Figure 33). The patent document described “a vertical plunger under the table having slanted sides and edges at its upper end” that would be “forced up into the slot in the bottom of the bottle” that would “cause the bottle to be turned” in order to line up the bottle to place the label in the desired spot. While this labeling machine was fully automatic, the one used in 1917 was almost certainly semiautomatic, requiring the presence of at least one operator, possibly more. It would nonetheless be more efficient than the earlier devices where the operator place the bottle by hand, lining up the label application by eye. Since earlier bottles had been made with slotted bases, that part of the operation was certainly not patentable.

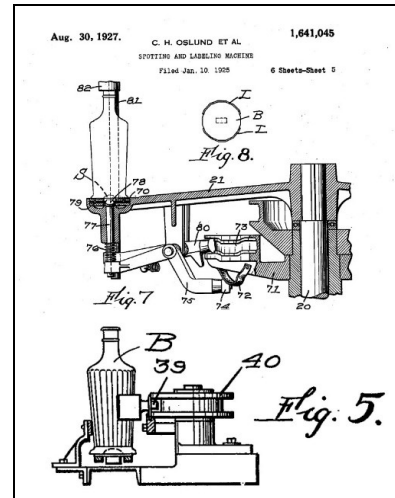

Figure 33 – Oslund & Johnson 1927 patent drawings

Brands and Paper Labels

Insofar as we can tell, Curtice Brothers only offered two brands of catsup between 1876 and 1925 – Imperial Ketchup and Blue Label Ketchup – although there may have been two others. A ceramic jug described below had a permanent label sealed in slip noting “Little Brown Jug / Catsup.” Since the word “Catsup” was below the other three words, it is unclear if “Little Brown Jug” was intended as a brand name for the catsup – the only instance we have found where Curtice Brothers used that spelling – or if it were merely a reference to the container.

One other possibility was H.H. Lee’s October 15, 1880, ad in the *Indianapolis News* that mentioned the arrival of “Curtice Brothers Celebrated New Tomato Ketchup.” Once again, we do not know whether “Celebrated New Tomato Ketchup” was intended as a descriptive term or as a brand name. It is highly probable that this reference was descriptive.

Of the certain two, the earliest ad we have found for Imperial Ketchup was placed in 1879, although the brand name was almost certainly used from at least 1876, when Curtice patented the ribbed bottle with its round label area – the same shape as the label. A trade card

dated 1885 shows that both the more squat, ribbed bottle and the round, Imperial Ketchup label survived to at least that year – probably until the adoption of the taller, narrower bottle (still ribbed) in 1887. Heinz also used the name imperial for one of its brands, but we have not discovered when Heinz first offered its Imperial Ketchup.

The drawing on the 1885 trade card is probably not an accurate representation of the actual label, but it is the only one we currently have discovered. To begin, the drawing showed a much thinner oval than the space on the actual bottle. The label showed a drawing of a tomato below the arched word “TOMATO” and above “CATSUP” in an inverted arch. Although the drawing showed “wings” extending from each side of the label, any wording was much too indistinct to be read under magnification (Figure 34).



Figure 34 – 1885 trade card (eBay)

The earliest ad for Blue Label Catsup in the new, taller bottle was placed in 1891 (possibly as early as 1888 in unreferenced ads), but the adoption of the bottle and the switch to the Blue Label brand name almost certainly occurred during the reorganization of 1887 (see discussion above at the beginning of the Bottles section and Figures 14 & 15). Both the Blue Label and the corresponding label area on the embossed bottles were square or rectangular.

Although both existing labels and advertisements between 1889 and 1925 showed slight variations in the Blue Labels, the basic format was “CURTICE BROTHERS CO. (horizontal) / BLUE LABEL (slight arch) / TOMATO (horizontal) / KETCHUP (slight inverted arch) / ROCHESTER, N. Y., U.S.A.



Figure 35 – Blue labels (eBay)

(horizontal)” (see Figure 15). As an example of additions, a 1909 ad showed “GUARANTEED FREE FROM ARTIFICIAL COLOR” above the Blue Label and “CONTAINS 1/10 OF 1% BENZOATE SODA” below it. The size of the bottle could appear as well as information on side panels (Figure 35).

Manufacturer's Marks

Numerous Curtice Brothers ketchup bottles – both mouth-blown and machine-made – were embossed with initials or logos that were rarely or never used otherwise. It seems virtually certain that Curtice Brothers required in 1901 that the manufacturers of its bottles emboss a company logo or initials on the bases of any bottles made for them (see more about this aspect in the Discussion and Conclusions section). In the case of the Owens Bottle Co., the firm continued to use the mark on other bottles, although most other glass houses discontinued the use of base logos at the end of the Curtice contract.

Most of the bottles discussed below had a single-digit number (rarely above 5, occasionally to 9) embossed either above or below the initial or initials, although three marks were accompanied by three- to four-digit numbers). With the exception of the date codes used by the Owens Bottle Co., these were almost certainly mold numbers. The smaller numbers (single-digits) were probably sequential mold numbers – i.e., 1 identified the first mold used for Curtice Brothers bottles, 2 was the second one, etc. Often, three- or four-digit base numbers were model numbers, sometimes for different sizes of bottles. Our sample of three- to four-digit Curtice bottles, however, was so small that we had too few numbers to make a statement.

Curtice Brothers was a large corporation by 1901, with a capital of 1.5 million dollars. Like the Anheuser-Busch brewing firm two decades earlier, it may have found itself in a position where its orders were higher than its bottle supply – so the firm may have begun buying from every ketchup bottle maker it could find. This led to bottles with at least 15 different manufacturer's marks from 11 different glass houses between 1887 and 1925.

Base and Finish Characteristics

Because the base and finish characteristics are important in determining whether a bottle was machine made or mouth blown – and *those* refinements are important in some dating – we offer a brief explanation of the important elements here. On the base, a machine scar is a thin circular line that is almost always off center (see Figure 19). An Owens machine scar was a similar line with “feathering” – i.e., fine lines like the edges of a feather – on one side, caused by the “knife” that cut the gob of glass after it was suctioned into the base (see Figure 19). On

occasion, an Owens' scar will show little or even no feathering, but that is unusual. When the "knife" was freshly sharpened, it left no scar, but it apparently became dull after only a few bottles. All machine scars were incised into the glass of the base – unlike embossing that protruded slightly.

A machine-made finish has two important elements – both seams. The side seam of the bottle continues through the finish to the rim at the top. On some bottles – notably most made by the Owens machine – the seam extends over the top of the finish. The second seam – much more important when making identifications through photos – is a horizontal seam that encircles the neck of the bottle just below the finish. This is always a sign of a machine-made bottle.

The mouth-blown, continuous-thread finishes on the Curtice Brothers ketchup bottles were unique to ketchup bottles and liquor flasks. In order to mold a continuous-thread finish on handmade bottles, the entire finish had to be created in the two side molds – an extension of the neck. After the bottle was blown into the mold, it was "wetted" off or broken off and tooled to make a smooth top above the threads. After being ground smooth, the rim was either heated in the glass pot or touched up with a blow torch to create a smooth surface – called fire polishing. From a diagnostic standpoint, this left the side seam of the bottle extending just above the threads, usually with horizontal striations from there to the rim – although those could disappear during the fire polishing process (see Figure 24).

The marks discussed below are presented in alphabetical order, even though two or even three of the logos belonged to the same glass manufacturer. The changes usually occurred because a reorganization created a name change or in cases where more than one factory belonged to the same firm. Their relationships are discussed in the individual mark section as well as the Discussions and Conclusions section.

Important Note

In the section below, all references to the Encyclopedia indicate sections of the Encyclopedia of Manufacturer's Marks on Glass Containers by the Bottle Research Group. This series of studies includes histories of each of the appropriate glass houses and everything we have been able to find or glean about individual manufacturer's marks on glass bottles and jars.

BB and B.B. Logos

The “BB” logo appeared in two formats on mouth-blown Curtice Brothers ketchup bottles with continuous-thread finishes: xxx / BB and B.B. / xxxx. With the exceptions of a single base embossed “5 / BB,” the “BB” logos with no punctuation were all below a three-digit number beginning with “5” (e.g., 546).

Although our sample is too small to be certain, these appear to have been sequential (Figure 36). The other format had “B.B.” (with punctuation) *above* a four-digit number, all in our sample beginning with “149” (e.g., 1498). With this format, the numbers in our sample were sequential (1493-1498 – Figure 37).



Figure 36 – BB logo

When we first studied the “B.B.” and “B.B.Co.” logos in 2013, we were somewhat ambivalent about whether the Bell Bottle Co. (1910-1914) or the Bellaire Bottle Co. (1882-ca. 1923) used these logos – or if each claimed one of them. However, we have found no evidence that Bell made ketchup bottles, but, Bell Bottle only opened in 1910, very late for the 1901-1911 period. We considered the Ball Brothers as the user of the “BB” logo (and/or “BBCo” and/or “BBGCo”), but Barry Bernas discovered that the Ball Brother’s Munsie, Indiana, location (1887-1922) only produced fruit jars – so it could not have made catsup bottles during the 1901-1911 period when the Curtice Brothers required manufacturer’s marks on its mouth-blown bottles.



Figure 37 – B.B. logo

We have only discovered two other glass firms with the correct initials during the 1901-1911 period: Bellaire Bottle Co. and Berney-Bond Glass Co. (see below for details about each company). But, we have determined that Bellaire Bottle was the likely user of the “BBCo” mark, and Berney-Bond almost certainly made bottles with the “B.B.G.Co” logo – so the big question is: Why would either firm have a second logo? For Bellaire Bottle, we have no answer.

However, Berney-Bond had two plants during the 1901-1911 period (and more later): Bradford (1904-1910) and Hazelhurst (1904-1928) – both in Pennsylvania. Each plant was open

during the required period, and Hazelhurst was a well-known catsup bottle producer (see below). Information on the Bradford plant has been more difficult to find, but Gray (1920) listed the Bradford plant as a maker of catsup bottles. Until or unless new information surfaces, the best bet for the “BB” and “B.B.” logos was the Hazelhurst plant with Bradford using the “B.B.G.Co” mark. For more information about the history and marks of the Ball Brothers, Bell Bottle Co., Bellaire Bottle Co., or Berney-Bond, see the appropriate sections of the Encyclopedia.

BBCo Logos



Figure 38 – BBCo (eBay)

Like the “BB” mark discussed above, “BBCo” had two formats. One had “BBCo” horizontally across the center of the base above a single-digit number (1-3 in our sample). The other had “B.B.Co.” inside an elongated diamond, with the second “B” and “C” larger than the other



Figure 39 – Diamond-BBCo

letters and the final period in the angle of the diamond so that it was centered after the “o” (Figures 38 & 39). Numbers in our sample ranged from 1-6, always below the logo. We have only discovered two glass houses that fit the initials – Bell Bottle Co. and Bellaire Bottle Co. As noted above, Bell Bottle opened just at the end of the 1901-1911 period, so the probable manufacturer was the Bellaire Bottle Co.

Located at Bellaire, Ohio, the Bellaire Bottle Co. was in business during the right time (1882-ca. 1923) and could easily have made mouth-blown Curtice Brothers bottles. Bellaire’s ca. 1910 catalog made it very clear that the plant’s primary focus was on prescription and medicinal bottles, but page 25 illustrated two types of ketchup bottles in various sizes – both with continuous-thread finishes (Figure 40). Since the Curtice Brothers bottles were patented – and private label – they were not shown in the



Figure 40 – Bellaire ca. 1910 catalog

catalog. We have not discovered why Bellaire would have used two formats for their mark styles. See the section on the Bellaire Bottle Co. in the Encyclopedia for more information.

B.B.G.Co. Logos

Once again, these “B.B.G.Co.” marks appeared in two formats – arched and horizontal, both with full punctuation and each above a three-digit number. In our sample, the arched variation ranged from 200-404, while the the horizontal range was 320-616 (Figures 41 & 42). Assuming that the sample was representative, this suggests that the horizontal style was used later than the arched variation. Like the “BB” and “B.B.” marks, the “B.B.G.Co” logo was more common than any other one – although our entire sample was small.



Figure 41 – B.B.G.Co. arch (eBay)

The Berney-Bond Glass Co. derived from a merger of the Berney Glass Co. (1900-1904) and the Bond Glass Co. (1902-1904) – both Pennsylvania glass houses – in 1904. Although the firm continued to make a variety of container, Berney-Bond began specializing in milk bottles, adopting the “BB48” and “BBGCo48” logos – the same as on the catsup bottles but with the addition of the national number assigned to the firm. Berney-



Figure 42 – B.B.G.Co. horiz.

Bond continued in operation until the Owens-Illinois Glass Co. purchased the firm to enter the milk bottle competition in 1930. The Bradford plant made ketchup bottles early, possibly from the beginning, and adopted small-mouth bottle machines by 1909. Although the plant burned in 1917, it was restored that same year. In 1922, Berney-Bond’s focus was on milk bottle production. It is highly likely that all ketchup bottle manufacture ceased by that year, if not earlier. See the Berney-Bond Glass Co. section of the Encyclopedia for more information.

Diamond-C Logo

We found a single example of a mouth-blown Curtice bottle with a C-in-a-horizontal diamond embossed on the base and an unclear number that may have been “1” (Figure 43). The

Chattanooga Bottle & Glass Mfg. Co., Chattanooga, Tennessee (1901-1930) used this logo, with various forms of diamonds, from 1901 to ca. 1913. This was the southernmost supplier of Curtice bottles that we have found. For more about the firm, see the Chattanooga Glass Co. section in the Encyclopedia.

CGCO and CGCO-in-a-Diamond

We have discovered two mouth-blown Curtice brothers bottles with similar basemarks – “C.G.CO. / 9” and “Diamond-CGCO / 5” (Figures 44 & 45). In both cases, the mark was centered on the base with a single-digit number below it. In the diamond logo, the “G” was larger than both “Cs” with the “o” smaller – conforming to the diamond shape. In both cases, the serif on each “G” extended downward, terminating in a point. Many glass houses had CGCo initials, so these two logos could have belonged to a single firm or two companies.

Of the glass houses that the Bottle Research Group has investigated, four are worth mentioning. The California Glass Co., California, Pennsylvania, used a “C.G.Co.” mark on the bases and heels of liquor flasks made for the South Carolina Dispensary during 1898 and 1899 – although there was no evidence that the firm used the initials on any other products. The Dispensary required its providers to emboss their initials on any bottles it used.

The Carolina Glass Co., Columbia, South Carolina, used a similar “C.G.Co.” logo on bottles it made for the Dispensary from 1902-1911. However, there is no evidence that the glass house made ketchup or any other types of food bottles. The Coshocton Glass Co., Coshocton, Ohio, also used the “CGCo” initials on soda bottles and possibly milks from 1907 to 1919. Again, we found no sign that the plant produced any food or ketchup bottles.



Figure 43 – Diamond-C (eBay)



Figure 44 – C.G.Co. (eBay)

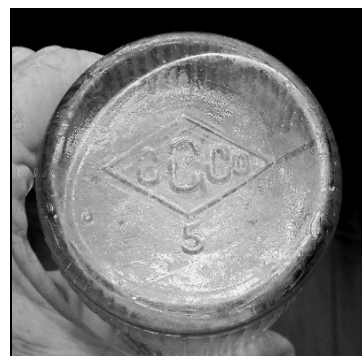

Figure 45 – Diamond-CGCo

Finally, the Cumberland Glass Mfg. Co., Bridgeton, New Jersey, made catsup and other food bottles at some point during its 1885-1920 period in business. Unfortunately, there was no evidence that the firm used the “CGCo” initials. However, since the Curtice Brothers obviously required glass houses to emboss their marks on ketchup bottles – in several other cases, factories that normally did not use marks – Cumberland Glass is our best bet as the user of these two marks, even though the initials did not include an “M” for “Mfg.” Despite this deduction, a currently unknown glass house could have used one or both logos instead. See the Cumberland Glass Co. section of the Encyclopedia for more information. Since Bridgeton is less than 20 miles south of the Curtice Brothers plant at Woodstown, it would have been a convenient location for bottles to that operation.

F and F with a circle of dots

These bases were produced in three formats, all accompanied by Owens scars (Figure 46). The earliest (and simplest) was a small “F” at the center of the base. The second format was the same “F” offset from the center because of a large slot. This central



Figure 46 – F logos (eBay)

slot was intended for machinery that would align the bottle to attach a glued label (e.g., see Schulz et al. 2016). In addition, the bottle was topped with a combination finish (discussed in the machine-made bottle section above). The final variation, still with the slot, had the “F” surrounded by an arc of dots, varying from one to twelve in number (for the month of manufacture) along with a single-digit number above the “F” and an occasional number below. The upper number was a date code (7, 8, or 9) indicating 1917, 1918, or 1919 – the only years when the system was used. The dot variation always included the slot.

The Fairmont factory of the Owens Bottle Machine Co. (at that time called the Owens West Virginia Bottle Co.) opened in 1909, making grape juice bottles. The plant also produced liquor ware for the Charles Boldt Glass Mfg. Co. but added catsup bottles (almost certainly for Curtice Brothers among others) by July of 1911. The small “F” on Curtice Brothers (and other catsup and grape juice bottles) was almost certainly first used about that year.

In August 1917, Owens added a single-digit year code above the “F” (e.g., 7 for 1917) and a series of dots (occasionally stars) to tell the month of manufacture. A dot to the right of the numeral indicated January, and the dots continued in a arc, a new one added each month, until a full circle of 12 dots equaled December. Thus far, we have only recorded eight and eleven dots (August and November) for 1918. Owens Bottle replaced the “F” mark with its Square-O logo in 1919, using the number 3 to indicate the Fairmont factory (Plant No. 3). See the Owens Bottle Co. section of the Encyclopedia for more information about the Owens firm and the section on Square-O logos below for more about the later logo.

F.E.R.&CO. and F.E.R.G.CO. Logos



Figure 47 – F.E.R.&CO. (eBay)

Two bases from mouth-blown Curtice bottles were marked similarly – “F.E.R.&CO. / 6” and “F.E.R.G.CO. / 1216” – both with letters in an arch (Figures 47 & 48). Growing out of the Rochester Glass Works, F.E. Reed & Co. took over the operation ca. 1903, making a general line of bottles, especially packers. The firm used the



Figure 48 – F.E.R.G.CO. (Ebay)

F.E.R.&Co logo from ca. 1903-at least 1913 on mouth-blown bottles.

About 1910, the firm reorganized as the F.E. Reed Glass Co. and used the F.E.R.G.CO. mark until the 1920s. Even though the plant now had machines, we have only seen the logo on mouth-blown Curtice bottles. Also see the section on “R” logos below and the F.E. Reed section of the Encyclopedia for more information on the glass house.

H and HA Logos

Our sample of these logos is tiny – just two of the “H”; three of the “HA” (Figures 49 & 50). The lone “H” was truly alone on one example (no accompanying number – and solarized amethyst), but the other had a “4” below it – both mouth blown. The “HA” marks had 2, 3, or 4 below the initials. The “HA” example with a “4” came from a drawing of a fragmented bottle in Berge (1980:116). One of the “HA” bottles was machine made with a combination finish, but

we could not be sure of the other two. See the discussion of the “F” logo above for more about the combination finish. Assuming that both of these marks were used by the same glass house, the factory (or factories) spanned the transition from hand production into the machine era.

Like the Berney-Bond Glass Co. (discussed above), the Hazel-Atlas Glass Co. was another merger in 1902, this one between the Hazel Glass Co. (1887-1902), the Atlas Glass Co. (1896-1902), and auxiliary firms. The Hazel Glass Co. began making ketchup bottles by 1893, certainly mouth blown. Although several other glass houses also used a single “H” mark, Hazel is the most likely one to emboss the letter on ketchup bottles (although, see the “JH” section below). Considering that both “H” and “HA” basemarks were the same size, the double-letter logo was probably a continuation. In addition, the 1908 Hazel-Atlas catalog featured a drawing of a Curtice Brothers bottle, an almost 100% assurance that the “HA” logo was used by Hazel-Atlas – and a suggestion that the “H” mark was used by the same firm (see Figure 31).

The Hazel Glass Co. developed one of the first really viable large-mouth bottle machines (the Blue Machine) in 1894, and Hazel-Atlas discontinued small-mouth ware (including ketchup bottles) in 1912. Blue designed a machine to make small-mouth bottles in 1900, but it could not have made catsup bottles. His drop-down parison required bottles with distinct shoulders – unlike the almost shoulderless catsup design. However, Hazel-Atlas received the Owens license to make packers’ ware in 1909 and had the machines installed and operational a year later. So, the mouth-blown bottles with “H” basemarks were likely only made between 1901 (when Curtice Brothers adopted their logo requirement) to 1902 or slightly thereafter (when the firm became Hazel-Atlas). Mouth-blown HA bottles were likely made between 1902 and 1911.

Hazel-Atlas reinstated small-mouth bottles in 1920, made with machines at the Zanesville factory. Since the firm did not adopt the well-known H-over-A logo until 1923, these HA ketchup bottles were almost certainly produced during this 1920-1923 period. At least one



Figure 49 – H logo (eBay)

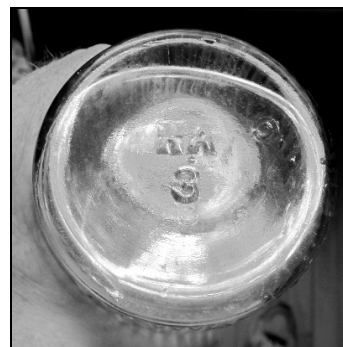

Figure 50 – HA logo

example had the combination finish (described in the Owens section below). See the section on the Hazel-Atlas Glass Co. in the Encyclopedia for more information.

The use of the combo finish brings up an interesting question: Why would the Curtice Brothers buy these bottles from Hazel-Atlas, when they already had adopted bottles with the same finish *and* the slotted base from the Owens Bottle Machine Co. at least three years earlier? Since use of the slotted base required a different sort of labeling machine – or at least a modification of an existing machine – this makes no sense – *unless* the same line could be adapted to use non-slotted bases.

I.G.CO. Logos

Our single example of this mark was embossed “I.G.CO.” horizontally across the center of the base with “2” below it. The bottle was mouth blown, even though the side seam extended all the way to the top of the finish, suggesting that the process was becoming more efficient with less tooling required (Figure 51). There was no parting line below the finish nor any other characteristic of a machine-made bottle. The logo was a common one for the Illinois Glass Co., Alton, Illinois (just across the river from St. Louis) – a well-known producer of catsup bottles. For more information, see the section on the Illinois Glass Co. in the Encyclopedia.



Figure 51 – I.G.CO.

J.G.CO. and J.G.C. Logos

We have only seen two examples of Curtice bottles embossed “J.G.CO.” horizontally across the base above the number “3” or “8.” In addition, a similar bottle was embossed “J.G.C.” over “5” (Figures 52 & 53). All examples were mouth blown.

The Jeanette Glass Co. was the likely user of the J.G.CO. and J.G.C. marks. The Jeanette Glass Co. succeeded the Jeanette Bottle Works in 1898 and made ketchup bottles by at least 1900. In



Figure 52 – J.G.CO. (eBay)

1924, the plant ceased production of bottles to concentrate on tableware. These bottles appear to be uncommon. See the Encyclopedia section on the Jeanette Glass Co. for more information.

JH Logo

We have only recorded a few examples of Curtice Brothers bottles with “JH” basemarks, all on mouth-blown containers (Figure 54). Assuming that the numbers above the “JH” initials were sequential mold codes, the glass house made the full-sized bottles in at least four molds (we have recorded codes of “2” and “4” located above the “JH”) plus at least one mold for the tiny sample-sized bottle (with no accompanying number).

After having reread the studies on Heinz, Hart, Hemingray, the Hamilton family, Holt, and the J files in general, the only two possibilities for the “JH” logo make *any* sense at all. Most likely was W.H. Hamilton & Co. after the move from Pittsburgh to Charleroi, Pennsylvania, in 1897. James M. Hamilton was general manager at that time. J.T. & H. Hamilton branched off of W.H. Hamilton & Co. in 1880. By 1904, James W. Hamilton was manager of the plant. In either case, the requirement for initials could have spurred the plant manager to use his own initials rather than longer ones. The even shorter “H” may have already been appropriated by the Hazel Glass Co. The Pittsburgh area was within the region of known suppliers of Curtice Brothers bottles.

James T. Hamilton may have been the money behind Wm. Hamilton & Co. – again, J.H. initials. Also connected were James M. Hamilton and Joseph S. Hamilton – two more “J.H.” possibilities. James M. provided the original glass experience. The plant moved to Charleroi, PA, in 1897 (1897-1909) with James M. Hamilton as general manager. The 1899 catalog (p. 42) illustrated “Champagne Ketchup, Metal Cap, Screw Top” in 8 oz. and 16 oz. sizes (Figure 55).



Figure 53 – J.G.C.



Figure 54 – JH (eBay)



Figure 55 – Hamilton 1899 catalog

A second possibility would be J.T. & H. Hamilton of Pittsburgh (1880-1916), producer of flint prescription bottles. In 1904, James W. Hamilton was manager of the plant. Possibly, James commissioned the bottles after Alexander’s murder in 1902 – although we have not discovered any historical source indicating that J.T. & H Hamilton made catsup bottles. However, it is also possible that the JH factory was a small plant that we have not yet discovered. For more information about the firms, see the Encyclopedia section on the Hamilton Glass Factories.

KG

Our only example was a simple “KG” with the “K” in the center of the base of a mouth-blown bottle and the “G” apparently added as an afterthought. The Kearns-Gorsuch Bottle Co. was located at Zanesville, Ohio, from 1893 to 1937, although Hazel-Atlas purchased the plant in 1920 and began making catsup bottles (and many other types) by machine at that time – the Hazel-Atlas reentry into the catsup bottle business. However, the typical KG logo was surrounded by an oval – lacking on this bottle (Figure 56). The trademark for the oval variation claimed a first use date of May 1, 1920, so the no-oval variation was almost certainly used prior to that time, probably in the pre-1911 period. See the section of the Encyclopedia on the Kearns factories for more informations.



Figure 56 – KG logo

Circle-M

Our only example, found in an antique store in Colorado, was embossed with a Circle-M in the center of the base above a “4” on a mouth-blown Curtice bottle that was solarized to a dark bluish amethyst (Figure 57). The obvious guess for a Circle-M logo is the Maryland Glass Corp., Baltimore, Maryland (1907-1956). The “M” in the circle is virtually identical with Maryland logos, so it remains our best guess as the manufacturer – obviously during the firm’s early days before it shifted almost exclusively to the production of



Figure 57 – Circle-M

cobalt blue containers. So, the Curtice bottles were probably blown in the 1907-1910 period. Maryland Glass had almost certainly ceased all hand production by 1913, possibly earlier. For more information, see the section on the Maryland Glass Corp. in the Encyclopedia.

Maryland Glass did not adopt a logo for its regular lines of bottles until 1921, so this was certainly the first use of the Circle-M by the firm – assuming that our identification is correct. The use of the mark on Curtice bottles in the 1907-1911 period may have influenced its later choice for use on the cobalt blue bottles.

Square-O Logos

One of the two largest groups of Curtice ketchup bottles in our sample had the Square-O basemark (the other was the “F” logo from the same glass house). These were accompanied by the typical double-digit codes used by the Owens Bottle Co., slotted bases, and combination finishes (see the “F” section above and the discussion below).

In 1919, the Owens Bottle Machine Co. reorganized as the Owens Bottle Co., marking a transition between being primarily a glass machine manufacturer and a concentration on bottle production. The firm adopted the Square-O logo (representing a “square” deal) and used it until the merger that created the Owens-Illinois Glass Co. in September 1929. The firm used two important code formats: 1) a single-digit number to the left of the logo to identify the plant and a single-digit number to the right as a date code; and 2) both numbers to the right of the Square-O – left digit for the factory, right for the date code.

Our sample included only the plant code for Factory No. 3 at Fairmont, West Virginia, the first plant to include heavy production of catsup bottles in 1911 (although, see the “T” logo below for more information on early Owens catsups). We have recorded date codes for 1920-1925 along with the logo but no codes – a format used in 1919 (Figure 58).

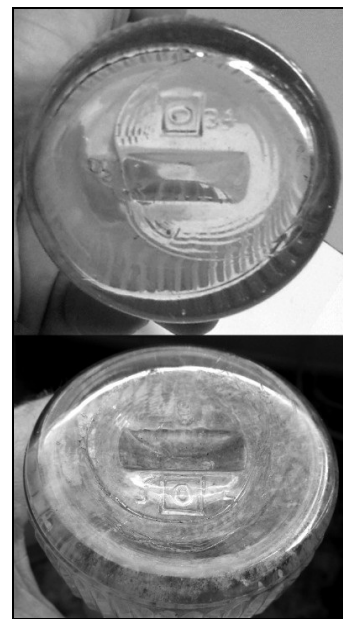

Figure 58 – Square-O (eBay)

These bases also included the large sunken slots and combination finishes as noted in the discussion about “F” logos above (see Figures 30 & 46). Described more fully in the Slotted Base section above, these slots were made to fit a specific machine for applying paper labels, turning each bottle to evenly paste the label within the square label space between the vertical ribs. One Square-O base had the logo facing one way with the codes (34) oriented at 90 degrees. See the Owens Bottle Co. section of the Encyclopedia for more information on the company. These bottles also used the combination finishes described in the Machine Made section above.

R Logo

These mouth-blown Curtice bottles had basemarks consisting of a simple letter “R” below a single-digit number (1-8 in our sample). We have only seen photos of the “R” logo on a few mouth-blown Curtice Brothers bottles with a concave bases (Figure 59). While the letter “R” could indicate any glass house beginning with that letter, we have only discovered one that made ketchup bottles during the correct period – the F.E. Reed Glass Co. (discussed in the F.E. Reed and the Rochester Glass Works section of the Encyclopedia). Since Reed used the “F.E.R.&Co.” logo from ca. 1903-ca. 1913 and the “F.E.R.G.Co.” mark from ca. 1910 until the 1920s, it is unclear when and why Reed chose the R logo, but it may have been adopted in 1901, prior to the selection of the longer, more complex logo and may have remained the mark of choice for the firm until the machine-made bottles gained prominence in 1911.



Figure 59 – R logo (eBay)

The “R” logo is much more common at online auctions than either of the longer strings of letters (with only a single example of each that we have ever encountered). Because the Reed factory was comparatively speaking in the back yard of the original Curtice plant in Rochester, we would expect a much larger sample of bottles with the Reed logos. But, the most common marks on mouth-blown bottles in our admittedly small sample were “B.B.” (probably Berney-Bond Glass Co.) and “B.B.G.Co.” (almost certainly Berney-Bond). Of all the glass companies in this study, Berney-Bond’s Bradford and Hazelhurst factories (just over the state line from eastern New York – in Pennsylvania) were the closest to the Curtice Rochester plant (122 miles and 129 miles respectively) – with the exception of the Rochester Glass Works, of course. This *may*

suggest two things. First, there must have been a quality control issue (or some other problem) with Reed bottles or with the company operations, or Curtice grew to the point where the Reed factory could not keep up with the demand. Second, Curtice Brothers seems to have given distance from its main factory a high priority. For more on distances, see the the Discussion and Conclusions section.

T Logo

One interesting exception to the general Curtice rules appeared in machine-made bottles. One of the Bottle Research Group members found an embossed Curtice bottle that did not fit the usual patterns (and we have found one more online since then). First, the medallion on the shoulder was embossed “CURTICE (arch) / BROTHERS CO. (inverted arch)” around a CBCO monogram that was similar to the monograms found on sample bottles (Figure 60). The second unexpected trait was the presence of a single small “T” as a basemark (Figure 61). In our initial assessment of this bottle, we assumed that the unfeathered mold scar was actually an Owens scar made with a new knife that left no scraping. At one side, there is just a hint of sloppiness on the scar.

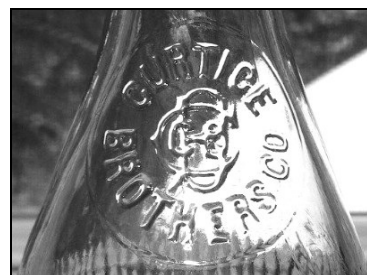

Figure 60 – Monogrammed Medallion

After checking other possible “T” factories, the Owens Bottle Machine Co. Plant No. 2 at Toledo remained the best explanation. The size of the letter “T” fits with the other letters used by Owens factories as well as with the other two examples we have seen of the “T” logo on other bottle types with distinctive Owens scars.

Originally opened as the Northwestern Ohio Bottle Co. in 1904, the factory became Plant No. 2 of the Owens Bottle Machine Co. in January of 1908, making eight-ounce catsup bottles on one of its two machines. We found no reports for catsup production at the factory after Plant No. 3 at Fairmont began the manufacture of catsup bottles in 1911. Thus, the bottles were likely produced in 1911 for a test market by the Curtice Brothers. Although the brothers had been using the CBCO monogram on sample bottles



Figure 61 – T logo

since at least 1890, this was the only bottle we have seen where the monogram was used on a regular-sized ketchup container.

The timing here brings up a coincidence that is too perfect to ignore. Our previous research on the early Owens logos and codes suggested that small letters identifying individual factories began to be used ca. 1914. However, the Fairmont plant began making catsup bottles in 1911, earlier than we suspected before. This timing suggests that the Owens Bottle Machine Co. probably began using manufacturer's marks (actually plant codes) on its bottles in response to the requirement by the Curtice concern. Owens then rapidly spread the use of the letters to its other factories. Assuming this hypothesis is correct – and it fits all of the known evidence – the Curtice Brothers were responsible for embossing of logos on packers' bottles and thence to other non-returnable containers.

Machine-Made – No Logo; Numbers Only

Another unusual marking on machine-made bottles was a single-digit number (2-4 in our sample) with no manufacturer's mark and a non-Owens machine scar. Currently, we have no solid evidence for these, but they could have been made by either an Owens plant using a non-Owens machine,¹ by Hazel-Atlas, or by another currently unknown glass house (Figure 62).



Figure 62 – Numbered machine base (eBay)

Cans, Jars, and Ceramics

Throughout the life of the Curtice Brothers, canning was the backbone of the company. While the term “canning” can (pun intended) mean glass containers – and Curtice certainly used jars – the bulk of the firm's products were packaged in tin cans. For example, the brothers advertised a drawing of a can in the December 28, 1886, issue of the *Rochester Democrat & Chronicle*, and a similar can drawing appeared in an 1893 catalog (Figure 63). One label example featured Red Raspberries (Figure 64). All can labels included the CBCO monogram.

¹ As the Owens Bottle Co. began buying up smaller firms, the company also acquired both the licenses for non-Owens machines as well as many of those machines in use at the newly bought factories.

Table 2 – Manufacturer’s Marks on Curtice Brothers Ketchup Bottles

Logo	Glass House	Location	Dates on Catusps
BB & B.B.	Berney-Bond Glass Co.	Hazelhurst, PA	1904-1911
BBCo	Bellaire Bottle Co.	Bellaire, OH	1901-1911
Diamond-B.B.Co.	Bellaire Bottle Co.	Bellaire, OH	1901-1911
B.B.G.Co. (arch)	Berney-Bond Glass Co.	Bradford, PA	1904-1911
B.B.G.Co. (horiz.)	Berney-Bond Glass Co.	Bradford, PA	1904-1911
Diamond-C	Chattanooga Glass Co.	Chattanooga, TN	1901-1911
C.G.CO.	Cumberland Glass Mfg. Co.	Bridgeton, NJ	1901-1911
Diamond-CGCO	Cumberland Glass Mfg. Co.	Bridgeton, NJ	1901-1911
F	Owens Bottle Mch. Co.	Fairmont, WV	1911-1919
F + dots	Owens Bottle Mch. Co.	Fairmont, WV	1911-1919
F.E.R.&CO.	F.E. Reed & Co.	Rochester, NY	1903-1911
F.E.R.G.CO.	F.E. Reed Glass Co.	Rochester, NY	1910-1911
H	Hazel Glass Co.	Washington, PA	1901-1902
HA	Hazel-Atlas Glass Co.	Washington, PA	1902-1914
I.G.CO.	Illinois Glass Co.	Alton, IL	1901-1911
J.G.CO.	Jannette Glass Co.	Jeanette, PA	1901-1911
J.G.C.	Jannette Glass Co.	Jeanette, PA	1901-1911
JH	W.H. Hamilton & Co.?	Charleroi, PA	1901-1909
KG	Kearns-Gorsuch Glass Co.	Zanesville, OH	1901-1909
Circle-M	Maryland Glass Corp.	Baltimore, OH	1907-1910
Square-O	Owens Bottle Co.	Fairmont, WV	1919-1925
R	F.E. Reed Glass Co.	Rochester, NY	1901-1911
T	Owens Bottle Mch. Co.	Machine	1911



Figure 63 – Can (eBay)

The Curtice Brothers packaged some of their early products in at least two types of glass jars, both with fancy designs. One was bell shaped with a metal lid and wire handle. The label on our example was for Blue Label Sweet Pickled Peaches (Figure 65). The base was embossed

“CURTICE BROTHERS (arch) / PRESERVERS (horizontal) / ROCHESTER, N.Y. (inverted arch)” – the same design used on the medallions of the ketchup bottles – but without the crosses. A narrow-mouth jar was mouth blown and had a one-part, rounded finish.

The side of this one was embossed “CURTICE BROTHERS (arch) / PRESERVERS (horizontal) / ROCHESTER, N.Y. (inverted arch)” – *not* in a plate – the same format used on the jar described above (Figure 66). The base was unmarked.

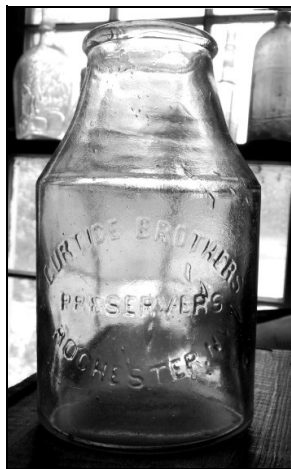

Figure 66 – Jar 2 (eBay)

Another looked more like a jug with embossed designs at shoulder and heel plus a metal cap with wire lid. Our example originally contained Mince Meat (Figure 67). The base was embossed “PATENTED (arch) / C-B (horizontal) / JULY 27TH 1888 (inverted arch)” (Figure 68). The patent, of course, was for the jar, but the “C-B” indicated the Curtice Brothers. Both of these were probably used during the period between the very late 1880s and ca. 1910 or so.

An unusual offering was a ceramic jug, brown on the lower half, light tan on the upper, obviously sealed with a cork. A leafy red



Figure 64 – Label (eBay)



Figure 65 – Jar 1 (eBay)



Figure 67 – Jar 3 (eBay)



Figure 68 – Jar 3 base (eBay)

tomato formed a label on the shoulder with the words “LITTLE BRWON JUG, / CATSUP, / CURTICE BROTHERS” (Figure 69 & 70). This may have been a very early container prior to the adoption of glass bottles – note the spelling of “catsup” instead of “ketchup” – or it may have been a specialty offering.



Figure 69 – Little Brown Jug (eBay)

Discussion and Conclusions

As noted in the text above, catsup bottle used by the Curtice Brothers followed five distinct time periods during the approximately 57 years that the firm bottled catsup in containers that were identifiable in the absence of their paper labels. All of these time spans featured different containers and patterns of selection for glass suppliers. Each of these roughly decade-long periods deserves its own discussion.



Figure 70 – Jug label (eBay)

A) 1868-1876 – Early Curtice Bottles

While we have not discovered the exact date when the Curtice Brothers first began preparing and bottling ketchup, it was probably ca. 1868. At this point, the operation was small, so few bottles have survived, only one that was certainly from the period and another might have been. It is possible that the earliest catsup (using that spelling) was bottled in ceramic containers and called Little Brown Jug Catsup. However, the jug may have been a later specialty item.

It is also possible that the brothers used generic bottles with paper labels during the earliest part of the period, but we have found a single example of a bulbous catsup bottle, certainly the style used during the 1870s, with the Curtice Brothers name embossed on it along with the the location and a unique CB monogram. Although not mentioned earlier in this study, Zumwalt (1980:101) also illustrated the same bulbous bottle and noted that it had an “iron or/oxide pushed-up pontil” and that the process was already outdated by 1868.

Since all canning/bottling occurred at the Rochester plant during this era, it is likely that the Rochester Glass Works provided all the bottles used by the Curtice Brothers. However, A.R. Samuel's Keystone Glass Co. continued to use an iron pontiled base until the 1868-1873 period, so Samuel is also a contender as the early Curtice ketchup bottle producer. It is also possible that Samuel created the initial bottles, then the Curtice Brothers switched to the closer glass house to make the containers (or possibly generic ones) during the 1870s.

B) 1876-1887 – mouth-blown bottles, cork finishes, shoulder embossing

This period began with the 1876 Edgar N. Curtice patent for a cork-stoppered bottle with numerous embossed vertical ribs and a sharp shoulder. Although not specified on the patent document, these bottles were embossed with the Curtice Brothers name and "PATENT" around the shoulder's edge. One variation (probably the older one) was made in a three-piece mold and had a two-part finish; the later one had a single-part finish, prepared in a two-piece mold. An 1885 trade card showed this distinctive bottle with an oval label (round on the actual bottles) that identified its contents as Imperial Ketchup (a brand name later used by Heinz). Although Curtice sales were increasing during this decade, catsup bottling remained confined to Rochester, so a local glass house was the logical supplier, most likely the Rochester Glass Works.

C) 1887-1901 – mouth-blown bottles, screw-tops, numbers on bases

The new bottle style both defined and set the date for the 1887-1901 Curtice Brothers era. These bottles retained the vertical ribs around the body, but the labeling area became rectangular (instead of round), and the finish morphed into continuous threads. As noted above, the production of continuous-thread finishes began on liquor flasks in the 1870s, but the 1888 patent for a ribbed cap for the finish probably makes the Curtice Brothers the initiators for continuous threads on used on catsup bottles. The cap could only fit on a continuous-thread finish, so the bottle had to have existed prior to that point. The finish had been patented for jars in 1854, so the application of threaded finishes to catsup bottles could not receive a new patent.

Although H.J. Heinz also used catsup bottles with continuous threads, the earliest Heinz patent to show them was in 1890. Verhast (2011:18), however, illustrated an early Heinz bottle

with a continuous-thread finish that he dated 1889. But, when the Curtice Brothers registered the Blue Label logo in 1906, they claimed an adoption date of 1887. Because those labels were rectangular, the bottle to fit them was obviously adopted in 1887, also, making it pretty certain that the Curtice Brothers adopted the taller bottle with the threaded finish in 1887.

Bottles from this period had two different basemarks. The first was unembossed – a plain base. The second consisted of a four-digit number in the center of the base (although smaller numbers are possible). This 14-year period was one of expansion. Along with opening two other plants locally in New York, the firm merged with another packer to form Curtice-Olney in 1893, adding the Olney canning plant at Woodstown, New Jersey (another catsup location), to its banner. Even though the name reverted to Curtice Brothers the following year, the Woodstown plant remained as a permanent part of the Curtice coterie. Although Curtice probably continued to rely on F.E. Reed (Rochester Glass Works) for the bulk of its bottles, the firm may have expanded its search for more bottles during this period.

D) 1901-1911 – mouth-blown bottles, screw-tops, basal logos

These bottles were identical to the ones used during the 1887-1901 period – with one major difference – all of these were basemarked with glass house initials. The table below – in alphabetical order – includes all the initials we have found on mouth-blown bottles, the probable glass house associated with the mark, dates of operation, and probable dates of use on Curtice Brothers catsup bottles. Identifications range from positive (e.g., I.G.Co. = Illinois Glass Co.) to *very* tenuous (e.g., JH = W.H. Hamilton & Co.), with most being certain or reasonably certain.

This was obviously a time of exploration, when the Curtice Brothers were searching farther and farther afield for bottles. In all likelihood, the quest was one for quality rather than quantity. Many of the glass houses involved were quite large and capable of producing plenty of bottles. Several, however, were small operations, again suggesting that quality was the goal.

Two things about this period are probably the most salient: proximity and concentration. If proximity were the primary consideration, the Rochester Glass Works bottles (marked with “F.E.R.&Co,” “F.E.R.G.Co.,” and probably “R”) would have outnumbered all others, but we have only discovered single examples of the first two very certain marks, although the “R” logos

had the third highest concentration in our small sample. However, the search ranged far and wide, not only encompassing relatively close glass houses like Berney-Bond (more about them below) but also such distant locations as the Illinois Glass Co. (816 miles from Rochester) and the Chattanooga Glass Co. (861 miles from Rochester). Just the Maryland Glass Corp. was close to Woodstown (81 miles away), but we have only found a single example with the Circle-M logo. If that was an attempt at using a local glass house, it apparently failed.

Concentration, however, somewhat supports the proximity hypothesis; i.e., that Curtice selected glass houses close to its plants. In our sample, the most common two marks on mouth-blown bottles were “B.B.” and “B.B.G.Co” – logos we have attributed to the Berney-Bond Glass Co. Once Berney-Bond specialized in milk bottles, again being required to use manufacturer’s marks as well as a specific number, it used “BB48” and “BBGCo48” to mark its bottles. Coincidence? The Berney Glass Co. and the Bond Glass Co. merged to form Berney-Bond in 1904, making bottles – including catsup bottles – in two plants at Bradford and Hazelhurst, Pennsylvania. Respectively, those locations are 122 and 129 miles from Rochester – the closest two glass plants of all the logos found on Curtice Brothers catsup bottles except for the Rochester Glass Works, practically in the Curtice back yard. As noted above, the “R” mark – which we have attributed to Rochester Glass – was the third most common among mouth-blown bottles.

All of this discussion suggests that the Curtice Brothers were willing to search far and wide for either quality or quantity of bottles – or possibly only to take advantage of sales. Bottlers of all kinds were known to be fickle about the glass industry. A large firm (like the Curtice Brothers) generally had large storage capacity and could buy several railroad carloads of bottles to take advantage of sales. It is thus possible (probable?) that the Curtice Brothers obtained most of their bottles from the local or close firms (Rochester Glass Works and Berney-Bond) but bought either a single large lots or occasional loads of bottles from almost any supplier as long as the sale price was low enough to cancel out the long distance shipping cost. Regardless of whether the reason was economic or quality oriented, the Berney-Bond policy of requiring manufacturer’s marks on its bottles has provided a unique chapter in bottle making history.

E) 1911-1925 – Owens machine-made bottles

The final era of marked Curtice Brothers bottles began when the firm discovered the immense quality difference in bottles made by the Owens Automatic Bottle Machine. In 1911, Curtice ordered a trial run of bottles from the Toledo factory, then the only Owens plant making catsup bottles. Although we have only seen two of these, each was marked with a “T” on the base and a machine scar with only the slightest bit of feathering on close inspection.

Later in the year, the Owens factory at Fairmont, West Virginia, began the serious commercial production of catsup bottles, each marked with an “F” in the center of the base and a distinctive feathered Owens scar. As noted above, these two initials (“T” and “F”) in 1911 are the earliest examples of a manufacturer’s mark used by the Owens Bottle Machine Co. – almost certainly only instigated by the Curtice basemark requirement. By at least 1915, other Owens plants implemented the initials idea, shifting to the inclusion of date and month codes in 1917, but dropping the month dots with the reorganization into the Owens Bottle Co. in 1919 – along with the logo change to the Square-O. Another major change occurred, apparently in 1917 – a switch to a combination finish at the top and a large slot in the base. The combination finish could take a crown, Goldy, or screw cap, and the slot created a positive alignment of the paper label within the labeling area at the front of the bottle. These two improvements continued in use until 1925, the last year that Curtice used the ribbed bottle.

F) 1920-? – large-mouth bottles with fluted sides

The Curtice Brothers introduced a wide-mouth, conical bottle with fluted sides and a rounded neck-shoulder area for the label in 1920 and gradually phased out the older style ribbed bottle by 1925. Although we have not researched how long these were used, the Owens-Illinois Glass Co. still made bottles for Curtice in the 1950s.

In summary, the Curtice Brothers introduced two major innovations into the field of packing bottles: continuous-thread finishes with aluminum screw caps and the requirement for manufacturer’s marks on bottle bases. While neither of these were new to the glass industry as a whole, both had dramatic and lasting impacts.

Although there is a chance that H.J. Heinz initiated the use of screw caps on catsup bottles, available evidence strongly points toward the Curtice Brothers as the instigators. The use of a threaded finish topped by a screw cap was vastly superior to the cork, and it soon became the industry standard for a catsup closure. The one slight flaw in the system was removed in 1911 with the adoption of machine-made bottles. These eliminated the imprecise seals due to slight differences in finish height that was inherent in hand production, creating a perfect, positive plug. The system was so effective that it remains in use during the 21st century.

The second innovation, requiring manufacturer's marks in 1901, had little effect on most glass houses that were involved. The majority only retained the system as long as the Curtice Brothers purchased their bottles – then returned to the lack of marking. A few already marked bottles and so continued their process. The effect on the Owens Bottle Machine Co., however, was dramatic and long lasting.

The inclusion of manufacturer's marks had been pioneered by the beverage and brewing industries on returnable bottles in the late 19th century as a form of quality control, but the Owens firm began with the idea of selling machines, only realizing belatedly that the concentration on machines was limiting. By that time, they had already committed to the exclusive license effectively freezing their own factories out of the returnable bottle field.

Like most producers of bottles that were not returnable, the Owens firm did not mark its containers – until it met the Curtice Brothers requirement in 1911. Owens then became obsessed with quality control, developing not only year codes in 1917 but even a series of dots that showed the *month* of production – although the firm dropped that finer line of dating in 1919. Soon, bottles produced by Owens and later the Owens-Illinois Glass Co. became some of the most datable containers found in archaeological projects and collectors' shelves.

One final addition in the Curtice/Heinz catsup bottle wars bears listing. Prior to 1880, virtually all containers were made from aqua glass – i.e., glass colored only by the iron impurities in the sand. Heinz appears to have adopted colorless glass in 1888, when he regained control of the firm. All of the Curtice Brothers 1876-patented bottles we have found were colorless glass (or hazy gray or solarized amethyst), suggesting that the Curtice firm once again preceded Heinz as the pioneer innovator.

Sources

Berge, Dale L.

1980 *Simpson Springs Station: Historical Archaeology in Western Utah*. Cultural Resource Series No. 6. Bureau of Land Management, Utah.

Bottle Research Group

2013-2021 *Encyclopedia of Manufacturer's Marks on Glass Containers*.

<https://sha.org/bottle/makersmarks.htm>

Glass Bottle Blowers Assn.

1911 *Proceedings of the Thirty-Fifth Annual Convention of the Glass Bottle Blowers Association of the United States and Canada, Held at Columbus, Ohio, July 10-22, 1911*. New Franklin Printing Co., Columbus, Ohio.

Gray, Grace Viall

1920 *Every Step in Canning: The Cold Pack Method*. Forbes & Co., Chicago.

Hill, Kathryn

2010 "Survey: Do You Say Catsup or Ketchup?"

<https://www.thekitchn.com/survey-do-you-say-catsup-or-ke-113016>

Lindsey, Bill

2022 "Bottle Finishes & Closures: Part II: Types or Styles of Finishes - Page 2.

<http://www.sha.org/bottle/finishstyles2.htm>

Peck, William F.

1908 *History of Rochester and Monroe Counties, New York, from the Earliest Historic Times to the Beginning of 1907*. Pioneer Publishing Co., New York.

Schulz, Peter D., Rebecca Allen, Bill Lindsey, and Jeanette K. Shult

2016 *Baffle Marks and Pontil Scars: A Reader on Historic Bottle Identification*. Special Publication Series No. 12. Society for Historical Archaeology, Germantown, Maryland.

Verhast, Marcell

2011 *Iconic Packaging: The Heinz Ketchup Bottle*. BIS Publishers, Amsterdam, Netherlands.

Wiggins, Jasmine

2014 “How was Ketchup Invented?” *National Geographics*

<https://www.nationalgeographic.com/culture/article/how-was-ketchup-invented>

Zumwalt, Betty

1980 *Ketchup Pickles Sauces: 19th Century Food in Glass*. Mark West Publications, Fulton, California.

Created 10/1/2022