

THE PROPER STORAGE AND DISPLAY
OF A PHOTOGRAPHIC COLLECTION*

by

Debbie Hess Norris

A typical photographic collection is likely to contain a wide variety of photographic negative and positive images. Early miniature cased objects including daguerreotypes, ambrotypes, and tintypes; mounted and unmounted historic and contemporary photographic prints in a variety of sizes and techniques; glass plate and film base negatives; and color transparencies may all be housed in a single collection. This collection may be in relatively good condition or contain evidences of deterioration and damage. There are many problems associated with the proper storage and display of such a complex collection. This discussion will address these issues as well as present basic guidelines to the identification of some specific photographic processes.

Although somewhat rare in many photographic collections cased objects will be found from time to time. The earliest photographic process to gain popularity in America was the daguerreotype. A daguerreotype photograph consists of a silver-plated sheet of copper with the whites or highlights of the image being a silver mercury amalgam and the darks pure silver metal. The daguerreotype surface is therefore mirrorlike and reflective. To enhance their effect color was sometimes added to daguerreotypes. In doing so finely ground pigments were applied dry or in combination with gum arabic to the finished plate. It is extremely important that light exposure for colored daguerreotypes be minimized since fugitive pigments were commonly used.

The ambrotype process was popular in America from 1850 to 1870. In this process a piece of glass was coated with collodion to which potassium iodide had been added. The plate was made light sensitive by immersion in a solution of silver nitrate. The glass plate was then exposed to light in a camera and immediately developed. Coloring was often achieved in the same manner as the daguerreotype. The ambrotype glass plate consists of white highlights with the shadows being clear glass. To complete the photograph the photographer backed the glass with black paper, velvet, or lacquer.

The tintype is essentially another kind of ambrotype. In this process collodion emulsion is coated on a sheet of black japanned iron to produce a direct positive image.

Once completed, daguerreotypes, ambrotypes, and some tintypes were usually sealed to a brass mat and cover glass, thus preventing dust and fingerprints from marring their delicate image surfaces. These protective packages were then fitted into standard-sized decorative miniature cases. These miniature cases have suffered through the years. Owing to excessive handling and poor storage and display conditions, these cases are often in many pieces.

These cased objects should be individually stored in fabricated acid-free folding boxes. These boxes are made of a medium weight buffered board. The boxes fold and are therefore free of adhesive. Labeling, including a 35mm contact print of the image, may be done on the outside of the box. This eliminates the need for labeling the case directly and cuts down on the handling of photographs when looking for a specific one. Once placed in their protective storage boxes, these objects can be stored flat or upright in an acid-free box or map cabinet.

*A paper presented to the Washington Conservation Guild, March 1983.

Many tintypes were pasted into paper cards whose window openings are often surrounded by a decorative embossed border. A good quality plastic sleeve will provide these loose tintypes with sufficient protection against handling and dirt. Sleeves of unplasticized cellulose triacetate or polyester can be recommended. Acid free paper envelopes may also be used, however, these envelopes are opaque which means additional handling in order to locate a particular image.

Because they are composed of a variety of materials it is difficult to propose ideal environmental conditions for the storage of daguerreotypes, ambrotypes, and tintypes. A relative humidity of 40-50% and temperature of 60-65°F is usually recommended as a safe median for most materials. The glasses used as glazing materials or actual supports of these photographic images are often chemically unstable due to an uneven distribution of salts within the glass structure. Such potentially unstable glasses should not be stored in high relative humidity conditions. In addition, brass mats, preservers and, of course, the tintype's iron support are prone to deterioration by corrosion at high relative humidity.

Even if a photographic collection contains few cased objects, it is very likely to house numerous mounted and unmounted photographic prints. The salted paper process, was one of the earliest photographic paper processes. Introduced in 1840 this process was universally used during the decade 1840-1850. Prints from this process have a matte surface. Under magnification the image or silver salts appear to be embedded in the paper fibers. Retouching is readily visible.

Introduced in 1850, albumen prints were one of the most common photographic prints available during the period from 1855-1895. Studio portraits and landscape or stereoviews of this era are especially likely to be albumen prints.

To make albumen prints a thin, smooth, high quality paper was floated on a solution of albumen or egg white, which contained sodium chloride. The paper was then sensitized in a silver nitrate solution to form light sensitive silver chloride in the albumen emulsion. The paper was exposed to daylight in direct contact with a negative until the image visually printed out. Following printing these photographs were often toned with gold chloride to enrich their color and improve their stability. Gold toning of albumen prints produced the familiar purplish-black image colors found in historic prints in good condition. Following toning these prints were fixed in a sodium thiosulphate solution to remove light reactive salts and washed. Like daguerreotypes and ambrotypes, albumen prints were often hand-colored. Watercolors and aniline dyes (introduced after 1860) were often used for hand-coloring.

As the paper stock was thin most prints were sold mounted on cardboard. These mounts usually consist of a poor quality lignified core sandwiched between two thin good quality papers. Current research at Rochester Institute of Technology indicates that at high relative humidity conditions lignin decomposition products will migrate and irreversibly stain albumen prints.

Albumen prints are often readily identified by the crackle pattern which develops in the albumen emulsion with age. This type of deterioration is often visible in raking light and readily visible under magnification.

Albumen prints in original condition are usually warm brown or purplish brown in tonality. Approximately 85% of albumen prints, however, show some stain formation in the white and highlight areas. Loss of highlight detail is also common in these cases. The presence of highlight yellowing and their characteristic surface texture are two of the most readily apparent indications that a given print is albumen.

Following 1860 much of the mass-produced albumen paper was tinted. Art reproductions, landscape and architectural views, and portraiture were the most common subject matter printed on tinted albumen papers. The dyes most commonly used for tinting the albumen emulsion were basic colors from the triphenylmethane class, for example, fushine. These dyes have very poor lightfastness.

Accelerated aging tests carried out by Sergio Burgi at the Eastman House in Rochester indicates that tinted albumen paper will present objectionable degrees of dye fading after short periods of light exposure. For example, a four month exposure in optimum gallery conditions, 5-10 footcandles of tungsten illumination filtered with ultraviolet absorbing plexiglass, will create objectionable fading in tinted albumen photographs.

The finely divided collodial form of silver in the albumen image makes it very susceptible to chemical changes and deterioration. Residual processing chemicals, in particular sodium thiosulphate or hypo, may stain and fade the silver image. Sulphur gases in the air and impurities in storage envelopes and enclosures may react with metallic silver, further promoting staining and fading. As previously mentioned, chemicals in cardboard mounts and mounting adhesives may also deteriorate the image and paper support.

Incubation studies of albumen prints carried out at RIT under the direction of Jim Reilly have revealed that the major cause of highlight yellowing may be the Maillard or protein sugar reaction. In this reaction the glucose and amino groups in the albumen protein condense to form a highly colored and insoluble compound. This yellowing reaction was found to be minimized in the pH range of 4-6 and to increase with increasing pH above 7. In fact, incubation at high relative humidity of processed albumen prints in contact with carbonate buffered papers was found to promote the yellowing process. Therefore, alkaline buffered filing enclosures are not recommended for albumen photographs.

The gelatin paper print has been the major printing process from its introduction in the late 1880's to the present time. In this process, paper is coated with an emulsion of silver halide in gelatin. The type of silver halide used effects the final image color produced. Gelatin chloride prints are usually warm-toned and have a reddish cast. Gelatin bromide prints, in comparison, are often cool toned and appear black and white. In general a gelatin print appears smooth surfaced, although gelatin prints may be matte, glossy, or highly textured. Under magnification the gelatin globules sparkle and are easily observed. The emulsion does not have a distinctive crackle pattern.

Gelatin photographic prints may discolor from residual processing chemicals, such as sodium thiosulphate or environmental factors such as contact with oxidizing gases. Hydrogen sulphide, ammonia, and sulphur dioxide common in polluted air promote the attack of atmospheric oxygen on silver images. Damaging oxidants commonly present in photographic storage areas include peroxides,

generated by a wide variety of common materials such as deteriorated paper, paint fumes, some plastics and bleached wood. Severely oxidized gelatin prints may exhibit an iridescent surface layer of silver, a silver mirror, which is most obvious in the deepest shadow areas where the largest amount of silver is present.

Silver based processes such as the albumen or gelatin process comprise the great majority of photographs, however, there are printing processes which utilize other light sensitive materials or metals. In these the image may be composed of pigments, dyes, or non-silver metals such as platinum, pladdium, or iron. Platinum prints and cyanotypes (blue prints) are examples of two of the most common non-silver processes. Unlike the silver processes platinum metal forms an image immune to oxidation and degradation. The image is permanent but the support is not. Platinum prints are often very brittle, acidic, and discolored owing to the presence of residual processing chemicals such as iron salts and acids. Unlike albumen photographs, platinum prints will benefit from storage in an acid-free buffered enclosure.

The proper and safe storage of mounted and unmounted photographic materials incorporates several basic concepts. Photographs should be individually foldered, sleeved, or interleaved within acid-free boxes and metal fire drawers. Ideally, each photograph should have its own enclosure. This diminishes the migration of residual processing chemicals from one image to another and lessens the amount of handling a photograph will undergo. Print materials must not be stored with photographic negatives because of possible transfer of harmful chemicals from one image to another.

Photographs should be stored in non-hygroscopic containers which are free of sulphur, acids, and peroxides. Suitable materials include uncoated cellulose triacetate, polyester film, and acid-free papers. Acid-free papers whose surface pH registers above 8 should be avoided. The use of buffered materials in contact with photographic albumen and gelatin emulsions is presently being researched. As previously mentioned, current research at RIT on albumen photographs indicates that at high relative humidity, buffered materials will in fact damage the photographic image, causing highlight fading and stain formation. Furthermore, care must be taken when storing cyanotype and contemporary color photographs, such as dye transfer prints, as high alkalinity will fade these images. Therefore, until all investigations into this matter are complete, acid-free neutral enclosures are preferred for the storage of most photographic print materials.

Paper enclosures are available in several forms including envelopes, seamless enclosures, and folders. Various types of paper envelopes are on the market. Those designated archival are generally made of buffered paper. (Light Impressions has recently made available an unbuffered envelope.) Two critical considerations with paper envelopes are the position of the glued seam and the adhesive used to seal it. The adhesive used should be non-hygroscopic and non-reactive. Filing envelopes should have a narrow side seam rather than a thick central seam. During storage the emulsion side of the photograph should always face away from the seam. The use of envelopes with a top flap is desirable as the flap prevents dust from entering the envelope. Ideally each envelope should only hold one photograph, however, when storing large contemporary black and

white photographic collections this is not always possible. Therefore, if necessary no more than 10-15 images should be housed in each envelope. Acidic kraft paper and glassine envelopes should never be used.

Often preferable to seamed envelopes are seamless enclosures. Seamless enclosures can be fabricated inhouse from rolls of acid-free paper or Tyvek, an opaque inert polyethylene manufactured by the duPont company. This folded enclosure, useful for both negatives and prints, has no adhesive seam to attract moisture and contribute to deterioration. Such enclosures should be standardized and made to fit easily in acid-free boxes. Information identifying the photographic image may be written in pencil on the outside of each enclosure. Conservation Resources, recently made available a four flap paper seamless enclosure. This paper, developed specifically for the archival storage of silver image photographs is unbuffered and made from alfa cellulose pulp. Light Impressions has also recently marketed a unbuffered paper designed specifically for photographic storage. Seamless enclosures could be fabricated inhouse by using this paper.

Weakened unmounted photographs in poor condition may be safely stored in folders made from heavy acid-free folder stock. A piece of polyester film that fits inside the folder is adhered along the inside edge with archival quality double-sided tape. The photograph is then placed under the polyester film. This type of folder is available commercially from Conservation Resources. Simple heavy weight acid-free folders constructed inhouse may also be used to house mounted photographic prints.

Plastic materials suitable for photographic storage include uncoated polyester film (specifically Mylar D or Melinix 516) and cellulose triacetate. Both films are exceptionally strong, durable, transparent, and dimensionally stable. It should be noted that at times cellulose triacetate may tend to cockle and develop undulations in its surface. When using plastic storage enclosures, special concern should be given to humidity control as photographic emulsions may tend to stick or ferrotype to the slick surface of these materials. The danger of condensation and possible ferrotyping occurs when a relative humidity in excess of 65% fluctuates rapidly from low RH to high RH. If humidity cannot be monitored below 65% paper storage enclosures should be used. The use of polyethylene in thin sheet film should be avoided. Numerous problems have been observed with it in regard to sticking to photographic emulsions. Polyvinyl chloride enclosures must also not be used for the storage of photographic prints.

A frequently recommended enclosure for photographic positive and negative materials is the uncoated polyester sleeve. In fact the American National Standards Institute recommends uncoated paper in its publication entitled, Requirements for Photographic Filing Enclosures for Storing Processed Films, Plates, and Papers (PH 1.53, 1978). (It should be noted that polyester is also widely used today as a support for negative materials.) Acid-free barrier boards may be cut to standard sizes and inserted into the plastic sleeves. The clear plastic sleeves allow the photograph to be viewed without being removed and therefore protects the photographs from scratches, dirt, and fingerprints. The acid-free board provides the photograph with additional support and allows the print to be identified without labeling directly on the image. Many of these sleeves are open at two or three ends. Care must be taken, therefore when handling sleeved photographs, that they are not allowed to slip and fall out of the enclosure.

One particular polyester sleeve design may be recommended for its superiority in handling. This sleeve opens along the long edge with a flap which allows insertion and removal of the photograph without sliding.

Polyester sleeves, open at both ends and made specifically for the storage of carte-de-visites, cabinet cards, stereoscopic views, and other standard sizes are available from Photo-file. These polyester sleeves have been frosted or treated on one side with silica dioxide, which dulls the plastic's shiny surface. Manufacturer's claim that such treatment reduces the chance of the photographic emulsion sticking to the plastic enclosure at high relative humidity although little additional research has been done to confirm these claims. Some photographic scientists and conservators feel that these polyester sleeves will scratch a photographic emulsion.

Mounted and unmounted photographs may also be matted with 100% acid-free ragboard window and back mats. Process Materials has recently introduced a matboard manufactured specifically for photographic use. At time of manufacture this unbuffered board has a pH value between 6.5 and 7.5. Rising Museum Photomount (produced by Rising Paper Company) is an unbuffered 100% ragboard.

Photographs may be hinged into their mats with Japanese paper hinges and wheat starch or methyl cellulose adhesive. These water-based adhesives may cause disfiguring cockling in a thin photographic paper such as albumen paper. For the past ten years Jerry Cohn at the Fogg Art Museum has used polyvinyl acetate AYAT in toluene as a hinging adhesive for unmounted albumen photographs. The hinging process for AYAT is similar to that for applying paste. The Japanese paper hinge is cut to size and brushed out with a 40% AYAT in toluene solution. The hinge is applied to the photograph and weighted. Following hinging the albumen paper support is flat and free of planar distortion. PVA resins harden by solvent evaporation and therefore remain reversible in organic solvents.

There is a need for a non-aqueous hinging method for photographs. Initial investigations carried out by Jerry Cohn at the Fogg Art Museum and by Debora Dyer Mayer at the Conservation Center for Art and Historic Artifacts reveals that PVA AYAT does not appear to cause physical distortion to the photographic support and is readily reversible. There are, however, several unanswered questions which continue to be researched, such as, What is the stability of photographic materials in contact with the resin? and how much of the resin is retained by the photographic support and emulsion after the hinge is removed? Furthermore, it must be remembered that many photographic emulsions, coatings, and colors are readily soluble in organic solvents. Serious and irreversible damage to the photographic artifact could be done without prior testing.

Photocorners may also be used to attach photographs into museum quality mats. Photocorners may be constructed from acid-free paper, medium weight Japanese tissue, or polyester film.

If intended for display, matted photographs may be inserted into what the Conservation Center of Art and Historic Artifacts describes as a sealed package (see Appendix .) A sealed package consists of a piece of ultraviolet filtering plexiglass at the front, the matted object, and polyester film at the reverse.

All edges are sealed with polyester film tape. This package buffers the object from drastic fluctuations in temperature and relative humidity as well as protects it from airborne dust and pollutants. Photographs should never be framed directly against glass or plexiglas.

During the past several decades archivists have begun drymounting their photographic print collections onto rigid boards to facilitate processing and handling. The long term effects of drymounting photographic prints have not been thoroughly tested and studied. There is for the following reasons some cause for concern: (1) The high temperature required for drymounting may dehydrate and thereby deteriorate photographic emulsions. Dry mount tissue should not be used with contemporary resin coated papers as there are long term adhesion problems coupled with the fact that high press heat may blister the paper's coating. (2) The dry mount tissues presently used have a tendency to yellow and embrittle with age. Such deterioration may locally fade and or stain a photographic image. Furthermore, once applied many of these tissues are quite difficult to remove. For these reasons it is strongly recommended that current dry mounting procedures if utilized be discontinued altogether.

Ideally, once individually matted, sleeved, or foldered photographs should be stored horizontally in acid-free boxes or flat file drawers. If necessary images 8 x 12" and smaller may be safely housed in vertical storage cabinets or manuscript boxes. Photographs housed in a vertical file should be separated by a non-flexible archival divider placed every five to ten inches. Dividers can be made of acid-free corrugated cardboard or 8 ply ragboard. These dividers will provide the photographic collection with additional structural support and thus prevent the severe warpage that often occurs with photographs improperly housed vertically.

Those responsible for photographic collections are fortunate to have available recommendations for the storage of photographic prints, plates, and films published by the American National Standards Institute (ANSI). ANSI standards suggest that photographic prints be stored under the following conditions: temperature less than 65°F, daily cycling greater than 7°F should be avoided, relative humidity 30-50%, emulsion layers become brittle below 30% and mold growth is promoted above 60%. Exposure to direct sunlight or light sources containing high levels of ultraviolet radiation should also be avoided. 5-15 foot candles of tungsten illumination is usually recommended.

While there are specific recommendations for optimum temperature and relative humidity levels, such data does not exist with regard to tolerable levels of air pollution. We have already demonstrated that certain chemical compounds present in the air may have a detrimental effect on photographic records. Sulphur dioxide for example will combine with oxygen and moisture in the air forming sulphuric acid which in very small amounts will cause images to fade. Furthermore, particulate matter contains abrasive material which may mechanically damage photographic emulsions. An air filtration system should therefore be installed in a photographic storage area.

The proper, safe, and economical storage of glass plate negatives is a problem which continues to plague photographic archives. Many glass plate negative collections are still housed in the original cardboard boxes from which they were purchased. For the most part, plates housed in this fashion are not individually foldered or sleeved. Their emulsions have therefore become abraded and scratched, especially along their outer edges. Other collections may be housed in kraft paper or glassine envelopes.

The problem with the storage of glass plate negatives are their weight, bulk, and fragility. Glass plate collections should be individually stored in acid-free paper envelopes or Tyvek seamless enclosures. The emulsion side of the plate should face away from the envelope seam. Plastic sleeves are inappropriate because they do not allow for the thickness of the glass support. Acidic kraft paper envelopes should not be used.

Glass plate negatives should be stored vertically on edge. Storage of glass plates in a vertical position is preferred because it prevents undue build-up of weight on the bottom plates, which inevitably occurs with stacking. Vertical storage also allows for better air circulation around the plates. The storage of each plate in its own enclosure prevents excess rubbing and abrasion on the plate. In addition, it permits the plates to be labeled and removed individually for study.

Cracked or broken glass plated require immediate attention. Cracked plates should be supported on their non-emulsion side with a clean, clear single-weight piece of glass of the same dimension. The supported plate should then be protected on the emulsion side with a piece of four-ply rag-board cut to the same size as the glass' plate negative. The sandwich may be sealed at all edges with Filmo plast tape. Subject matter and condition may be noted on the ragboard support.

Broken glass plate negatives should be disassembled. Pieces should not be allowed to contact each other since contact may further damage these pieces. Each piece should be carefully wrapped in acid-free paper and transferred to a labeled envelope of appropriate size. In this manner deteriorated plates may be safely stored to await conservation treatment.

The preservation and conservation process for photographic collections is not an urgent one in the sense that an immediate deadline must be met. Rather, it is a question of first establishing priorities--dealing with the oldest records or those that show signs of deterioration and then instituting a continuing program of collections inspection. A relative urgent situation may, however, exist with photographic collections of early film negatives. Many such negatives are on a nitrate base which is an inherently unstable material.

Cellulose nitrate film ignites easily, burns rapidly, and when on fire produces toxic and combustible nitrogen oxides and carbon monoxide. The ignition temperature of stable nitrate film is 300°F as compared with 600-700°F for paper. Deteriorated nitrate film may ignite at temperatures as low as 120°F. It is, therefore, of utmost important that the cellulose nitrate materials in a collection be identified and immediately separated from other photographic and archival materials. Cellulose nitrate film

decomposes because of its inherent instability. High ambient storage temperatures and high relative humidity conditions accelerate decomposition. Moisture entrapped in the nitrate-based film converts nitrogen dioxide released by the film to corrosive nitric acid. Further rate of decomposition nearly doubles with every 10°C increase in temperature.

A detailed guideline specifying five stages of nitrate film decomposition was established in the 1950's. In the first stage the film base exhibits an amber discoloration with a simultaneous increased fading of the picture image. During the second stage the photographic emulsion becomes adhesive-like and the films tend to stick together. The film contains gas bubbles and emits a noxious odor in the third stage. As the fourth stage progresses the film is soft and welded to adjacent film and frequently covered with an opaque viscous froth. This froth covering the emulsion side of the film appears iridescent and obscures the photographic image. Finally, in the fifth stage the film mass becomes very brittle and degenerates partially or entirely into a brownish acrid powder.

Any film manufactured prior to 1950 should be suspected of being cellulose nitrate. Safety base sheet film began to replace the nitrate base film in the late 1930's. The first safety base film was made from cellulose acetate. In 1937 cellulose diacetate and in 1947 cellulose triacetate film was introduced. However, during this time, various nitrate film types continued to also be produced.

In the early safety films, cellulose nitrate was used in the adhesive sub-layer between the gelatin emulsion and the film base. Deterioration of these films is visible in the following ways: The film base shrinks drastically. The gelatin emulsion separates from the film base in channels, creating sharp, random ripples in the film, and the cellulose nitrate adhesive layer deteriorates trapping tiny gas bubbles between the gelatin emulsion and the film base.

An established method for film type identification is the float test. A small strip from the margin of the negative is placed in a test tube or graduated cylinder of a trichloroethylene/trichloroethane solution. If the sample sinks, it is a nitrate-based film. If it floats it is a safety based or polyester film.

A second identification method involves burning a sample of the film in question. A small sample from the negative's margin, held by a pair of tweezers under a fume hood is ignited by a match. Cellulose nitrate produces a flash flame that is difficult to extinguish whereas safety film ignites with difficulty and then will burn itself out. Another system of identifying cellulose nitrate film is by the presence or absence of edge printing on the negative. Film manufactured prior to the early 1930's did not have any edge printing. Later manufacturers printed safety or nitrate on the edge of the negatives margin. A negative which is not edge printed safety should be assumed to be on nitrate base unless positive identification to the contrary is established.

Once identified and separated from the rest of the collection, cellulose nitrate film and severely deteriorated safety based film should be copied. There are several methods currently available for copying nitrate film, each having its own particular advantages and disadvantages. Prior to making a commitment to any particular system, one should become familiar with all options and discuss them with a knowledgeable photographer and/or institution.

Once successfully copied, nitrate film should be stored in an isolated area, separate from other photographic and archival materials. Ideally, nitrate film should be housed in a cold storage vault. Sealing and storing in a standard domestic refrigerator is another possible approach for nitrate collections. In this sealed condition artifacts experience dark, low temperature and low relative humidity environment that minimizes their rate of deterioration.

If refrigeration is not possible, nitrate film may be kept at room temperature under the following conditions. The film should be stored in a room whose atmosphere is exhausted directly to the outside. Nitrate negatives should be housed in buffered envelopes. (Plastic enclosures seal in the deterioration products which then react with and further deteriorate the image.) The temperature should be kept at the lowest degree possible with a corresponding relative humidity between 30-40%. Because of the dangerous nature of cellulose nitrate film, many building codes and insurance policies restrict the use of present conventional negative storage systems for cellulose nitrate within a public institution. In fact, any institution housing cellulose nitrate film may risk immediate cancellation of its insurance policy. For this reason, building codes and insurance policies must be thoroughly examined prior to storage of cellulose nitrate materials.

In conclusion concern over the preservation of photographic materials is relatively recent. Our experience and knowledge is therefore somewhat limited. Because of this, recommendations for ideal environmental conditions and photographic enclosures may change in the years to come. Fortunately important research into photographic deterioration mechanisms and possible safe conservation treatment is increasing steadily thereby enabling the preservation of photographic materials to be more effectively implemented.

DN:c1

4/4/83

PROCEDURE FOR MAKING PROTECTIVE BOXES TO HOUSE CASED OBJECTS
(DAGUERREOTYPES, AMBROTYPES, AND TINTYPES)

For non-standard size cases the jackets must be custom made to fit.

1. Cut a square of acid-free board (.010 - .020" thick) whose sides are about 2-1/4 times longer than the largest dimension of the miniature case.
2. Mark the center of the board by drawing the diagonals of the square. Place the case diagonally at the center. Mark the corners of the case and then set the case aside.
3. Connect the marked corners using a straightedge and a No.2 pencil - continue these lines out to the edge of the acid-free board.
4. Cut the triangles out of the edges.
5. With a utility knife score the inner rectangle.
6. Measure the depth of the case. Mark this distance on each "arm" of the acid-free board, measuring out from the inner rectangle. Score a line at this position on each arm.
7. Fold the jacket along the scored lines. Place the case in the jacket and check for fit, adjusting as necessary.
8. Cut the notch and slit which represent the clasp at a convenient location - the case should be made to fit snugly but not tightly.

Most cases were mass produced and consequently are of standard sizes. Templates may be easily made.

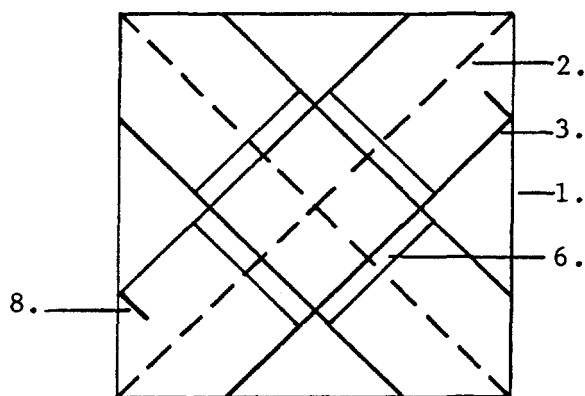

* Credit for this design to go to Chris King and Ellen Tenentes

Three-sided Folder for Photographic Storage

Weakened, unmounted photographs in poor condition may be carefully stored in the following manner. This storage system has been adapted from the storage system which is presently used at the Library of Congress for the safe storage of their print collection.

Procedure:

1. Along the outer edge of an unbuffered acid-free closed folder record (in pencil) the photograph's subject and photographer, if known.
2. Open folder. Cut a piece of polyester film which is slightly smaller (1" less in width, $\frac{1}{2}$ " less in height) than the folder's inner dimensions.
3. Cut a piece of acid-free unbuffered paper which is slightly smaller than the polyester sheet. This sheet must be larger than the photograph to be housed.
4. Cut a strip of 3M 415 double-sided tape the exact length of the polyester sheet. Place the double-sided tape along the outer edge of the opened folder. (see diagram)
5. Align the polyester sheet along the inner edge of the folder and adhere it to the double-sided tape. Make sure that strong contact has been established between the polyester sheet, the double-sided tape, and the acid-free folder.
6. Lift back the polyester sheet, place the photograph to be housed on the acid-free piece of paper, and carefully slip the photograph and paper under the polyester sheet. Owing to its electrostatic properties the polyester sheet will cling to the photograph and thus hold it safely in place. (Because of this electrostatic property polyester film must not be used for the storage of photographic materials with flaking or friable media.)
7. To examine the photograph the viewer need only open the folder.

As Folder Appears When Opened:

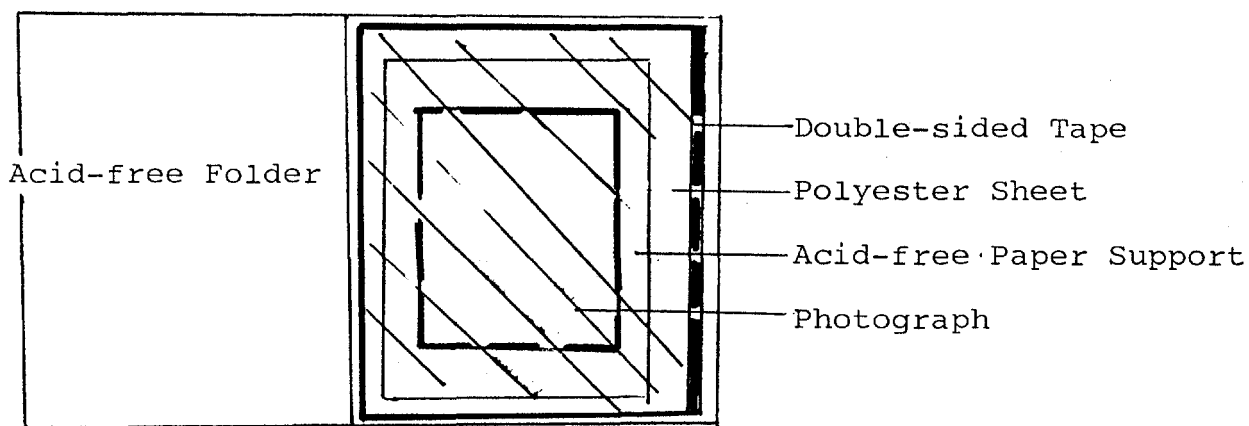

APPENDIXINSTRUCTIONS FOR MAKING A SEALED PACKAGE

- 1) Once the object is matted and hinged in its ragboard mat, cut a piece of glass or plexiglas, the exact size of the mat, and a piece of polyester film very slightly smaller than the mat (about 1/8" on each side) - this keeps the polyester film flat.
- 2) After cleaning the glazing material and polyester film with plastic cleaner or other suitable cleanser, sandwich the matted object between the glass and the polyester film, and position the sandwich so it slightly overhangs the table. (A light felted weight may be used to anchor the other end to prevent slipping.)
- 3) Apply polyester film tape to the edges of the glass and then wrap it around the edges of the package, adhering it to the polyester film on the reverse. The tape should not overlap the edges of the glass or plexiglas more than 1/8 - 1/4", since anything wider will not be covered by the frame rabbet, and will show on the obverse after framing. Polyester tape of a sufficient width should be used to entirely wrap around the edges of the package and adhere to the reverse.
- 4) Once the sealed package is constructed, it can be placed in the frame and affixed with brads. (We recommend a brad setter to minimize vibration and shock to the object and the sealed package in general.)

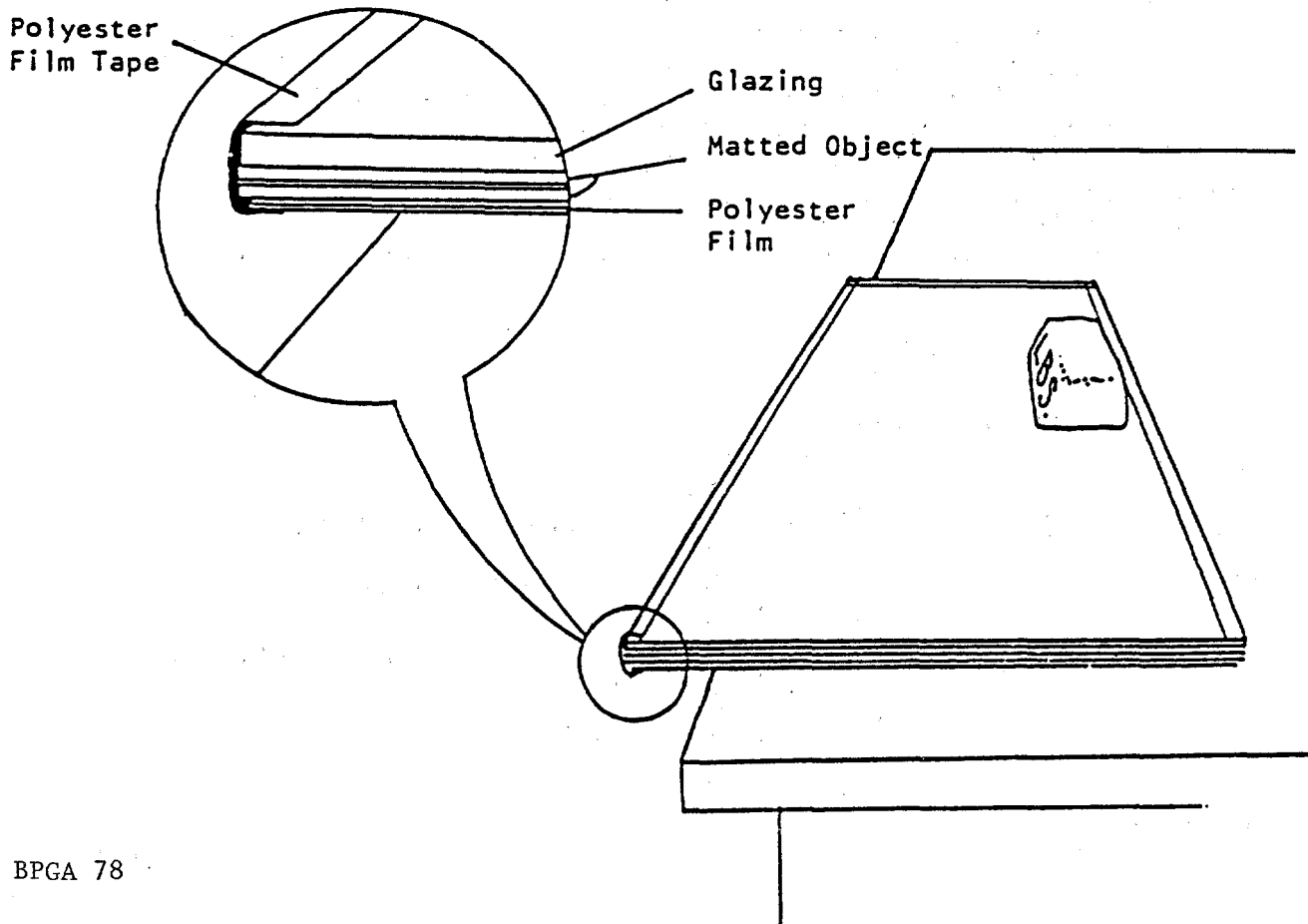

SUPPLIERS FOR PHOTOGRAPHIC STORAGE ENCLOSURES

Conservation Resources International
111 North Royal Street
Alexandria, Virginia 22314
(703) 549-6610

The Hollinger Corporation
P.O. Box 6185
3810 South Four Mile Run Drive
Arlington, Virginia 22206
(703) 671-6600

Light Impressions
P.O. Box 3012
Rochester, New York 14614
(716) 271-8960

Photofile
2000 Lewis Avenue
Zion, Illinois 60099
(312) 872-7557

Process Materials Corporation
301 Veterans Boulevard
Rutherford, New Jersey 07070
(201) 935-2900

Rising Paper Company
Housatonic, MA 01236
(413) 274-3345

TALAS
Technical Library Service
104 Fifth Avenue
New York, New York 10011
(212) 675-0718

University Products, Inc.
P.O. Box 101
South Canal Street
Holyoke, Massachusetts 01040
(800) 628-1912

BIBLIOGRAPHY

- Burgi, Sergio, "Fading of Dyes used for Tinting Unsensitized Albumen Paper," International Symposium: The Stability and Preservation of Photographic Images, Society of Photographic Scientists and Engineers, Public Archives of Canada, Ottawa, Ontario, August 29 - September 1, 1982, pp. 19-20.
- Calhoun, J. M., "Storage of Nitrate Amateur Still Camera Film Negatives," Journal of the Biological Photograph Association, Vol. 21, No. 3, August 1953.
- Crawford, William, The Keepers of Light, Morgan and Morgan, Dobbs Ferry, New York, 1979.
- Gill, Arthur T., Photographic Processes, a Glossary and Chart for Recognition, Museum Association Information Sheet, 87 Charlotte Street, London WIP 2BX, England, No. 21, 1978.
- Haist, Grant, Modern Photographic Processing, John Wiley and Sons, New York, 1979.
- Haynes, Ric, "A Temporary Storage Method to Retard the Deterioration of Cellulose Nitrate Film Negatives," AIC Preprints, 1981, pp. 75-81.
- Hendriks, Klaus B., "The Conservation of Photographic Materials," Picture Scope, Vol. 30, No. 1, Spring 1982, pp. 4-11.
- King, Chris, "My Grandmother has One of Those -- Daguerreotypes, Ambrotypes, Tintypes -- Their Problems, Processes and Care," Conference of Students in Art Conservation, April 10-12, 1978, pp. 82-97.
- Kodaic, Preservation of Photographs, Kodak Publication No. G-30, Rochester, New York, 1979.
- Norris, Debbie Hess, "Platinum: The Prince of Photographic Print Materials," Art Conservation Training Program Conference, Fogg Art Museum, April 30, May 1-2, 1979.
- Orraca, Jose', "Philosophy of Conservation," Address to the Society of American Archivists, Toronto, Canada, October 1, 1974.
- Porter, Mary Kay, "Filing Enclosures for Black and White Negatives," Picturescope, Fall 1981, p. 108.
- Reilly, James, The Albumen and Salted Paper Book, Light Impressions, Rochester, New York, 1979.
- , "Role of the Maillard, or "Protein-Sugar" Reaction in Highlight Yellowing of Albumen Photographic Prints," AIC Preprints, 1982, pp.160-168.
- , "Albumen Prints: A Summary of New Research About Their Preservation," Picturescope, Vol. 30, No. 1, Spring 1982, pp. 34-37.

Remple, Siegfried, "The Care of Black and White Photographic Collections; Identification of Processes," Technical Bulletin, No. 6, Canadian Conservation Institute, November, 1979.

-----, "The Care of Black and White Photographic Collections" Cleaning and Stabilization," Technical Bulletin, No. 9, Canadian Conservation Institute, December, 1980.

Royal Photographic Society of Great Britain (14 South Audley Street, London, W14 5DP, England) Symposium, March 16, 1964, "The Recognition of Early Photographic Processes, Their Care and Conservation," (five papers obtained from the Society.)

Swan, Alice, "The Preservation of Daguerreotypes," AIC Preprints, 1981, pp.164-172.

-----, "Conservation of Photographic Print Collections," Library Trends, Fall 1981, pp. 267-297.

Weinstein, Robert A., and Larry Booth, Collection Use and Care of Historical Photographs, American Association for State and Local History, Nashville, 1977.

Witkin, Lee, The Photograph Collector's Guide, New York Graphic Society, New York, 1979.