

Konrad Zuse's Legacy: The Architecture of the Z1 and Z3

RAÚL ROJAS

This paper provides a detailed description of the architecture of the Z1 and Z3 computing machines that Konrad Zuse designed in Berlin between 1936 and 1941. The necessary basic information was obtained from a careful evaluation of the patent application Zuse filed in 1941. Additional insight was gained from a software simulation of the machine's logic. The Z1 was built using purely mechanical components; the Z3 used electromechanical relays. However, both machines shared a common logical structure, and their programming model was the same. I argue that both the Z1 and the Z3 possessed features akin to those of modern computers: The memory and processor were separate units, and the processor could handle floating-point numbers and compute the four basic arithmetical operations as well as the square root of a number. The program was stored on punched tape and was read sequentially. In the last section of this paper, I put the architecture of the Z1 and Z3 into historical perspective by offering a comparison with computing machines built in other countries.

Introduction

Konrad Zuse is popularly recognized in Germany as the father of the computer, and his Z1, a programmable automaton built from 1936 to 1938, has been called the first computer in the world. Other nations reserve this honor for one of their own scientists, and there has been a long and often acrimonious debate on the issue of who is the true inventor of the computer. Sometimes the discussion is preempted by specifying in full detail the technological features of a specific machine. The Electronic Numerical Integrator and Computer (ENIAC), for example, has been called the first "large-scale general-purpose electronic computer in the world."² The ENIAC was built at the Moore School of Electrical Engineering of the University of Pennsylvania from May 1943 to 1945. It solved its first problem in December 1945 and was officially presented in February 1946. Another contender for the title of the first computer is the Mark I, built by Howard Aiken at Harvard University between 1939 and 1944. The Mark I was an electromechanical machine, not of the all-mechanical nature of previous computing devices and not built with the electronics available at the time.¹ The machine John Atanasoff built (later called the ABC) at Iowa State College from 1938 to 1942 used vacuum tubes but was restricted to the addition and subtraction of vectors and had a structure inappropriate for universal computation.² In direct contrast to these three machines, the Z1 was more flexible and was designed to execute a long and modifiable sequence of instructions contained on a punched tape. Zuse's machines, the Z3 and the Z4, were not electronic and were of reduced size. Since the Z3 was completed and was successfully working prior to the Mark I, it has been called the first *programmable*

calculating machine in the world. Of course the old debate will not be closed with this paper, but I want to show here just how advanced the machines Zuse built were when considered from the viewpoint of modern computer architecture and compared with other designs of that time.

The Berlin Polytechnic student Zuse started thinking about computing machines in the 1930s. He realized that he could construct an automaton capable of executing a sequence of arithmetical operations like those needed to compute mathematical tables. Coming from a civil engineering background, he had no formal training in electronics and was not acquainted with the technology used in conventional mechanical calculators. This nominal deficit worked to his advantage, however, because he had to rethink the whole problem of arithmetic computation and thus hit on new and original solutions.

Zuse decided to build his first experimental calculating machine exploiting two main ideas:

- the machine would work with binary numbers
- the computing and control unit would be separated from the storage.

Years before John von Neumann explained the advantages of a computer architecture in which the processor is separated from the memory, Zuse had already arrived at the same solution. However, it must be said that Charles Babbage had the same idea in the previous century when he designed his Analytical Engine. In 1936, Zuse completed the memory of the machine he had planned. (Zuse called it the *Speicherwerk* (storage mecha-

Konrad Zuse's Legacy

nism)—the term *Speicher* is still used in German instead of the anthropomorphic term *memory* that von Neumann introduced; Babbage used the term *store*.) It was a mechanical device but not of the usual type. Instead of using gears (as Babbage had done in the previous century), Zuse implemented logical and arithmetical operations using sliding metallic rods. The rods could move in only one of two directions (forward or backward) and therefore were appropriate for a binary machine.¹⁵ The processor of the Z1 was completed a few months after the storage unit, using the same kind of technology. It worked in concert with the memory but was never very reliable. The main problem was the precise synchronization that was needed in order to avoid applying excessive mechanical stress on the moving parts. It is interesting to point out that in the same year that Zuse completed the memory of the Z1, Alan Turing wrote his ground-breaking paper on computable numbers, in which he formalized the intuitive concept of computability.

The Z1, although unreliable, showed that the architectural design was sound and compelled Zuse to start investigating other kinds of technology. Following the advice of his friend Helmut Schreyer, he considered using electromechanical relays. Zuse built an “intermediate” simpler model (the Z2) using a hybrid approach (a processor built out of relays and a mechanical memory). In 1938, Zuse started building the Z3, a machine consisting purely of relays but with the same logical structure as the Z1. It was ready and operational in 1941, four years before the ENIAC.

This paper offers a detailed discussion of the architecture of the Z1 and Z3. Zuse reconstructed the Z1 himself in Berlin during the 1980s, and it is now one of the exhibition attractions at the Berlin Museum of Transportation and Technology. However, the information available describes only the design of the mechanical memory.¹² Zuse documented the Z3 in his patent application Z-391 of 1941, which is rather difficult to decipher due to the non-standard notation and terminology.¹⁴ K.-H. Czauderna's book⁴ about the Z3 is a good source to understand the historical environment surrounding Zuse's inventions but does not describe the Z3 in detail. In what follows, since Z1 and Z3 were equivalent from the logical and functional points of view, I refer only to the Z3. The main architectural difference between the Z1 and Z3 was the fact that the square root operation was left out of the Z1. There were also minor differences in the number of bits used for arithmetical operations in the processor (the Z1 used one fewer bit for the mantissa of floating-point numbers) and the number of cycles needed for each instruction. With this minor caveat and taking only the architectural features into account, one can speak of the Z1 and Z3 as nearly equivalent machines. There has been some discussion as to whether or not the reconstructed Z1 really corresponds to the original Z1 destroyed during World War II. Zuse rebuilt the Z1 during the 1980s based on his own recollections, and it could well be the case that the final machine ended being more similar to the Z3 than the original Z1. However, Zuse states in his memoirs that the basic circuits of the Z1 and Z3 were equivalent,¹⁵ and he confirmed this aspect of his work in a private interview.

Architectural Overview of the Z1 and Z3

This section summarizes the most relevant architectural features of the Z3. The paper moves from the simple to the complex: First, I provide an overview of the architecture, then I go into more

detail. In order to avoid awkward sentences, I will refer to the Z3 in the present tense.

Block Structure

The Z3 is a floating-point machine. Whereas other early computing automatons like the Mark I, the ABC, and the ENIAC worked with fixed-point numbers, Zuse decided very early on to adopt what he called “semilogarithmic” notation, which corresponds to the modern floating-point representation.

Fig. 1 is an overview of the main building blocks of the Z3. The first relevant feature is the separation between processor and memory. The Z3 consists of a binary memory unit (capable of storing 64 floating-point numbers), a binary floating-point processor, a control unit, and I/O devices. Memory and the arithmetical unit are connected through a data bus, which transmits the exponent and significand of the floating-point representation. The control unit contains the microsequencers needed for each instruction. Control lines going from the control unit to the processor, the memory, and the I/O devices enforce the correct synchronization of all units. The tape reader provides the opcode of each instruction as well as the address for memory accesses. The I/O devices are connected through a data bus to the computing unit.

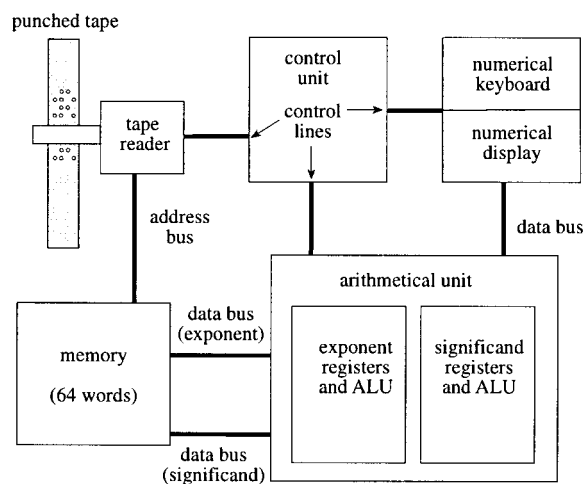

Fig. 1. The building blocks of the Z3.

Floating-Point Representation

Fig. 2 shows the representation used in the memory of the Z3. The first bit is used to store the sign of the number, the following seven bits for the exponent, and the last 14 bits for the significand (only the 14 places to the right of the decimal point). The bits of the exponent are called Part A of the number and are denoted by a_6, \dots, a_0 . The bits of the significand are called Part B of the number and are denoted by $b_0, b_{-1}, \dots, b_{-14}$. The exponent is coded as a two's complement number. The range of possible values therefore runs from -64 to 63 . The significand is stored in *normalized* form, that is, the first digit before the decimal point (b_0) must always be a one (Donald Knuth attributes the invention of *normalized* floating-point numbers to Zuse.⁵). This digit does not need to be stored (and therefore does not appear in Fig. 2), so that the effective range of the numbers in the memory unit is

equivalent to a significand of 15 bits. However, there is a problem with the number zero, which cannot be expressed using a normalized significand. The Z3 uses the convention that any significand with exponent -64 is to be considered equal to zero. Any number with exponent 63 is considered infinitely large. Operations involving zero and infinity are treated as exceptions, and special hardware monitors the numbers loaded in the processor in order to set the exception flags (see below). With this convention, the smallest number representable in the memory of the Z3 is $2^{-63} = 1.08 \times 10^{-19}$, and the largest is $1.999 \times 2^{62} = 9.2 \times 10^{18}$. The arguments for computations can be entered as decimal numbers on the keyboard of the Z3 (four digits). The exponent of the decimal representation is entered by pushing the appropriate button in a row of buttons labeled $-8, -7, \dots, 7, 8$. The original Z3 could accept input only between 1×10^{-8} and $9,999 \times 10^8$. Zuse's reconstruction of the Z3 for the Deutsches Museum in Munich provides enough buttons for larger exponents. With this arrangement, the whole numerical capacity of the machine can be reflected on the acceptable input. The same can be said of the output. However, the Z3 does not print the numerical results the program produces. A single number is displayed on an array of lamps representing the digits from zero to nine. The largest number that can be displayed is 19,999. The smallest is 00001. The largest exponent that can be displayed is $+8$, the smallest -8 .

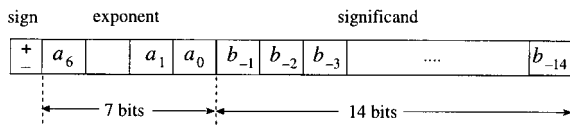

Fig. 2. The floating-point representation in memory.

Instruction Set

The program for the Z3 is stored on punched tape. One instruction is coded using eight bits for each row of the tape. The instruction set of the Z3 consists of the nine instructions shown in Table 1. There are three types of instructions: I/O, memory, and arithmetical operators. The opcode has a variable length of two or five bits. Memory operations encode the address of a word in the lower six bits, that is, the addressing space has a maximum size of 64 words, as mentioned above.

The instructions on the punched tape can be arranged in any order. The instructions Lu and Ld (read from keyboard and display result, respectively) halt the machine, so that the operator has enough time to input a number or write down a result. The machine is then restarted and continues processing the program.

The instruction most conspicuously absent from the instruction set of the Z3 is conditional branching. Loops can be implemented by the simple expedient of bringing together the two ends of the punched tape, but there is no way to implement conditional sequences of instructions. The Z3 is therefore not a universal computer in the sense of Turing.

Number of Cycles

The Z3 is a clocked machine. Each cycle is divided into five stages called I, II, III, IV, and V. The instruction in the punched tape is decoded in Stage I of a cycle. The two basic arithmetical

operations of the machine are addition and subtraction of exponents and significands. The operations can be executed in the first three stages of each cycle. Stages IV and V are used to prepare arguments for the next operation or to write back results.

TABLE 1
INSTRUCTION SET AND OPCODES OF THE Z3

Type	Instruction	Description	Opcode
I/O	Lu	read keyboard	01 110000
	Ld	display result	01 111000
memory	Pr z	load address z	11 z ₆ z ₅ z ₄ z ₃ z ₂ z ₁
	Ps z	store address z	10 z ₆ z ₅ z ₄ z ₃ z ₂ z ₁
arithmetic	Lm	multiplication	01 001000
	Li	division	01 010000
	Lw	square root	01 011000
	Ls ₁	addition	01 100000
	Ls ₂	subtraction	01 101000

The instructions implemented in the Z3 require the following number of cycles:

- Multiplication: 16 cycles
- Division: 18 cycles
- Square root: 20 cycles
- Addition: 3 cycles
- Subtraction: 4 or 5 cycles, depending on the result
- Read keyboard: 9 to 41 cycles, depending on the exponent
- Display output: 9 to 41 cycles, depending on the exponent
- Load from memory: 1 cycle
- Store to memory: 0 or 1 cycle

According to Zuse, the time required for a multiplication was three seconds. Considering that a multiplication operation needs 16 cycles, one can estimate that the operating frequency of the Z3 was $16/3 \approx 5.33$ Hz. It is a curious coincidence that the gate-level simulation of the Z3 that my students implemented using a personal computer also required around three seconds for a multiplication.

The instruction most conspicuously absent from the instruction set of the Z3 is conditional branching.

The number of cycles needed for the *read* and *display* instructions is variable, because it depends on the exponent of the arguments. Since the input has to be converted from decimal to binary representation, the number of multiplications needed with the factor 10 or 0.1 is dictated by the decimal exponent (see below).

Addition and subtraction require more than one cycle because, in the case of floating-point numbers, care has to be taken to set the size of the exponent of both arguments to the same value. This requires some extra comparisons and shifting.

A number can be stored in memory in *zero* cycles when the result of the last arithmetical operation can be redirected to the desired memory address. In this case, the cycle needed for the store instruction overlaps the last cycle of the arithmetical operation.

Programming Model

It is very important to describe the programming model of the Z3, that is, the part of the machine visible to the programmer. From the point of view of the software, the Z3 consists of 64 memory words that can be loaded into two floating-point registers, which I simply call R1 and R2. These two registers contain the two arguments of arithmetical operations requiring them. The programmer can write any sequence of instructions, but has to keep in mind the state of the machine's registers.

The important point to remember is the following: The first load operation in a program (Pr z) transfers the contents of address z to R1. Any other subsequent load operation transfers a word from memory to R2. A read keyboard instruction loads the numerical input into R1 and clears R2, which is used to hold temporary values during the transformation of the decimal input to a binary representation.

Arithmetical operations do not specify their arguments in the opcode. Their implicit semantics are the following:

Multiplication:	R1:=R1 × R2
Division:	R1:=R1/R2
Addition:	R1 :=R1+R2
Subtraction:	R1:=R1-R2
Square root:	R1:=sqrt(R1)

R2 is set to zero after an arithmetical instruction, whereas the result is stored in R1. Subsequent load operations refer to R2. The store and display instructions always refer to R1, which also contains the result of the previous arithmetical operation. After a store or a display operation, R1 is set to zero (by disconnecting its relays, which then become ready to accept a new value). The next load operation refers to R1.

An example is better than many additional remarks to clarify the programming model of the Z3. Assume that we want to compute a polynomial using Horner's method:

$$x(a_2 + x(a_3 + xa_4)) + a_1.$$

Assume further that we have stored the constants a_4, a_3, a_2, a_1 in the addresses four, three, two, and one of the memory unit. The value z is stored in address five. The program that performs the desired computation is the following:

Pr 4	load a_4 in R1
Pr 5	load x in R2
Lm	multiply R1 and R2, result in R1
Pr 3	load a_3 in R2
LS ₁	add R1 and R2, result in R1
Pr 5	load x in R2
Lm	multiply R1 and R2, result in R1
Pr 2	load a_2 in R2
LS ₁	add R1 and R2, result in R1
Pr 5	load x in R2
Lm	multiply R1 and R2, result in R1
Pr 1	load a_1 in R2
LS ₁	add R1 and R2, result in R1
Ld	display result

After the last instruction has been executed, the processor is reset to its initial state. A new program sequence can then be started.

Block Diagram of the Z3

In this section, I take a closer look at the structure of the Z3 and describe its main building blocks in more detail. The main issue is how to enforce the correct synchronization of the available components.

The Processor

Fig. 3 shows a simplified representation of the arithmetical unit of the Z3. There are two parts: The left side is used for operations with the exponents of the floating-point numbers, the right side for operations with the significands. Af and Bf are registers used to store the exponent and significand of what, from the programmer's point of view, is R1. I will refer to R1 as the register pair <Af,Bf>. The register pair <Ab,Bb> stores the exponent and significand of R2. The pair <Aa,Ba> contains the exponent and the significand of a third temporary floating-point register invisible to the programmer. The two arithmetic logic units (ALUs) A and B are used to add or subtract exponents and significands, respectively. The result of the operation in the exponent part is put into Ae. In the significand part, the result of the operation is put into Be. The pair <Ae,Be> can be considered an internal register invisible to the programmer. In Part B, a multiplexer allows selection of Ba or the output of the ALU as the result of the operation. The multiplexer is controlled by a relay Bt (if Bt = 0, then Be is set equal to Ba).

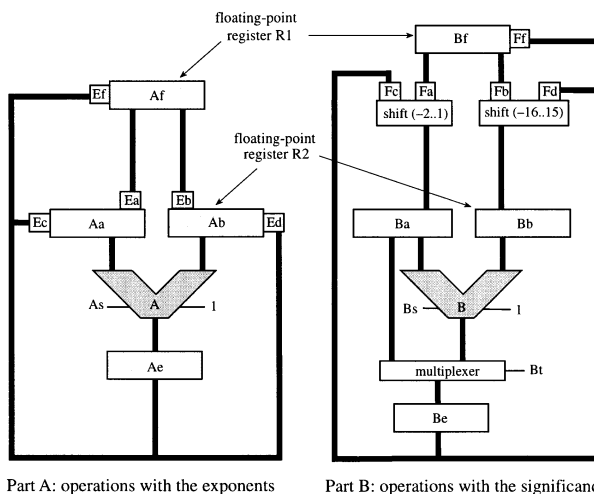

Fig. 3. The registers and data path.

The small boxes labeled Ea, Eb, Ec, Ed, Ef, Fa, Fb, Fc, Fd, and Ff are switches that open or close the data bus. If the contents of register Af are to be transferred to Aa, for example, the box of relays Ea is set to one and the result is Aa:=Af. As can be seen from Fig. 3, the contents of Af can be transferred to Aa or Ab, whereas the contents of Ae can be transferred to any of Aa, Ab, or Af according to the state of the switches. The structure of Part B of the arithmetical unit is very similar, but in addition to the multiplexer controlled by the relay Bt, there is also a shifter between

Bf and Ba and a shifter between Bf and Bb. The first shifter can displace the significand up to two positions to the right and one position to the left. This amounts to a division of Bf by four or a multiplication with the constant two. The second shifter can displace the significand in Af from one to 16 positions to the right and from one to 15 positions to the left. These shifts are needed for addition and subtraction of floating-point numbers. Multiplication and division with powers of two can therefore be performed when the operands for the next arithmetical operation are fetched and, in this sense, do not consume time.

The number of bits used in the registers is as follows:

Af	7 bits	Bf	17 bits
Aa	8	Ba	19
Ab	8	Bb	18
Ae	8	Be	18

As can be seen from this list, Ae uses one extra bit to handle the addition of the exponents of the arguments. Part B of the processor uses two extra bits for the significands (b_{-15} and b_{-16}) and makes explicit b_0 , which is not stored in memory. The extra bits at positions -15 and -16 are included to increase the precision of the computations. Therefore, the total number of bits needed to store the result of an arithmetical operation in Bf is 17 bits. Registers Ba and Bb require more extra bits (ba_2 , ba_1 , and bb_1) to handle intermediate results of some of the numerical algorithms. In particular, the square root algorithm can lead to partial computations in Ba requiring three bits to the left of the decimal point.

The basic primitive operation of the data path is the addition or subtraction of exponents or significands. When the relay As or Bs is set, the negation of the second argument (Ab or Bb) is fed into the ALU. Therefore, if the relay As is set to one, the ALU in Part A subtracts its arguments, otherwise they are added. The same is true for Part B and the relay Bs. The constant of one is needed to build the two's complement of a number.

Assume that two numbers with the same exponent are to be added. The first exponent is stored in Af, the second in Ab. Since they are equal, no operation has to be performed on this side of the machine. In Part B, the significand of the first number is stored in Bf and the significand of the second in Bb. The first step consists of loading Ba with Bf by setting the relay box Fa to one. The addition is performed next, the relay Bt is set to one, and so the result $Ba + Bb$ is assigned to Be. The relay box Ff is now set to one, and the result is stored in Bf. As one can see, the information can move between registers and so flow through the data path. The computer architect has to provide the correct sequence of activations of the relay boxes in order to get the desired operation. This is done in the Z3 using a technique very similar to microprogramming.

The Control Unit

Fig. 4 shows a more detailed diagram of the control unit and of the I/O panels. The circuit Pa decodes the opcode of the instruction read from the punched tape. If it is a memory instruction, circuit Pb sets the address bus to the value of the lower six bits of the opcode. The control unit determines the correct microsequencing of the instructions. There are special circuits for each of the operations in the instruction set.

Circuit Z represents the panel of buttons used to enter a decimal number in the machine. Only one button in each of the four columns can be activated. The exponent is set by pressing one of the buttons labeled -8 to 8 in circuit K. The output display is very similar to the input panel, but here lamps illuminate the appropriate decimal digits, the exponent of the number (circuit Q), as well as its sign. Note that there is a fifth digit for the output (which can be only one or zero).

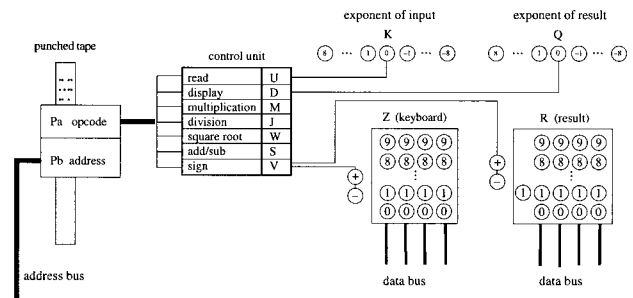

Fig. 4. The control unit and I/O panels.

Once a decimal number has been set, a data bus transmits the digits to register Ba, and a complex series of operations is started. The decimal input must be transformed into a binary number. This requires a chain of multiplications, which is longer according to the absolute magnitude of the exponent. If the exponent is zero, the whole transformation requires nine cycles, but if it is -8 , the operation requires $9 + 4 \times 8 = 41$ cycles.

There are a lot of details that the engineer designing the “microprogram” must keep in mind, otherwise short circuits can destroy the hardware.

Microcontrol of the Z3

The heart of the control unit is made up of its microsequencers. Before I describe the way they work, it is necessary to take a closer look at the chaining of arithmetical instructions in the Z3. Fig. 5 shows the main idea. Each cycle of the Z3 is divided into five stages. Stages IV and V are used to move information around in the machine. During Stages I, II, and III, an addition/subtraction is computed in Part A and another in Part B of the Z3. I call this the “execute” phase of an instruction. A typical instruction fetches its arguments, executes, and writes back the result. Zuse took great care to save execution time by overlapping the fetch stage of the next instruction with the write-back stage of the current one. One can think of an execution cycle as consisting of just two stages, as shown in Fig. 5, where the first two cycles of a series of instructions have been labeled. I have adopted this convention in the tabular diagrams of the numerical algorithms discussed later in this article.

The microsequencing is done by special control wheels. There is one for the multiplication algorithm, another to control division, and yet another for the square root instruction. The moving arm shown in Fig. 6 starts moving clockwise as soon as the control

Konrad Zuse's Legacy

unit decodes the corresponding instruction. In each cycle, the arm moves from one position to the next. The arm conducts electricity and activates the circuits with which it comes into contact. In the example shown in Fig. 6, the moving arm sets the relay box Ea to one in the first cycle. This leads to the transfer of the contents of register Af into Aa. In the next cycle, the relay boxes Ec and Fc are activated. In this way, the results of the operations in Parts A and B are written back into the registers Aa and Ba, respectively. As one can see, such control wheels provide a comfortable platform for modifying the exact sequence of events during an operation. They correspond to the microsequencers used today in modern microprocessors. I stop short of calling them a form of microprogramming, because in this case the microsequence has been hardwired, but it is obvious that microsequencing and microprogramming are closely related.

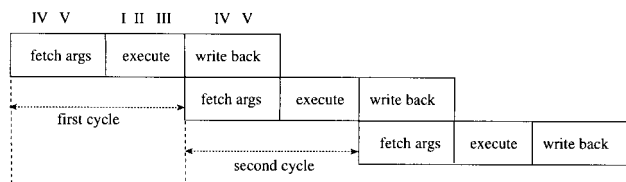

Fig. 5. The execution pipeline of the Z3.

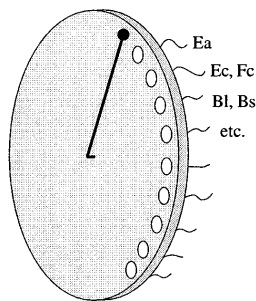

Fig. 6. Control wheels for microsequencing.

Extensive use of microsequencing allowed Zuse to simplify the Z3. Once the basic circuits had been laid out, it was just a matter of refining the control until optimal sequences of events could be found. There are a lot of details that the engineer designing the “microprogram” must keep in mind, otherwise short circuits can destroy the hardware. The Z1 with its mechanical design was still more sensitive in this respect than the Z3. Even after it was completed, there were sequences of instructions that the programmer had to avoid in order not to damage the hardware. One of those sequences was inadvertently tried at the Berlin Museum of Technology and Transportation, which led to slight damaging of the reconstructed Z1 in 1994.

The Adders

An important feature of the Z3 is the design of the adders, which compute additions and subtractions using a method called *carry look-ahead*. If binary addition is implemented in a straightforward way, carries have to be passed from one bit position to the next. In

the case of the significand, one would need 16 cycles just for the transmission of the carry bits. The adders Zuse designed are much faster than that—they perform an addition or subtraction in Stages I, II, and III of a single cycle. Subtraction is computed by complementing the second argument and adding an extra digit one at the lowest bit position.

Consider addition of the registers Ba and Bb. I will refer to the *i*th bit of register Bb by bb_i or $Bb[i]$, whatever form seems more convenient. I will use the same notation in the case of other registers. First of all, a partial result is computed that is the bitwise XOR of both registers, i.e., $bc_i = ba_i \text{ XOR } bb_i$. A second partial result is the bitwise AND operation applied to both registers, i.e., $ba_i \text{ AND } bb_i$. The next operation locates the bit positions at which a carry is needed. The intermediate results bd_i are computed by using the circuit shown in Fig. 7. Please note that when a bit is one, the corresponding line carries a current, otherwise the line is disconnected from the power source (so that no short circuit can occur). The resting positions of the relays bc_1, \dots, bc_{16} are the ones shown in Fig. 7. If bit bc_i becomes equal to one, the corresponding relay is closed. The final result is $be_i = bd_i \text{ XOR } bc_i$. Note that the use of relays makes the propagation of the carries up to the last bit position needed easier. Since all relays are activated simultaneously, the carry is not delayed going from one bit position to the next.

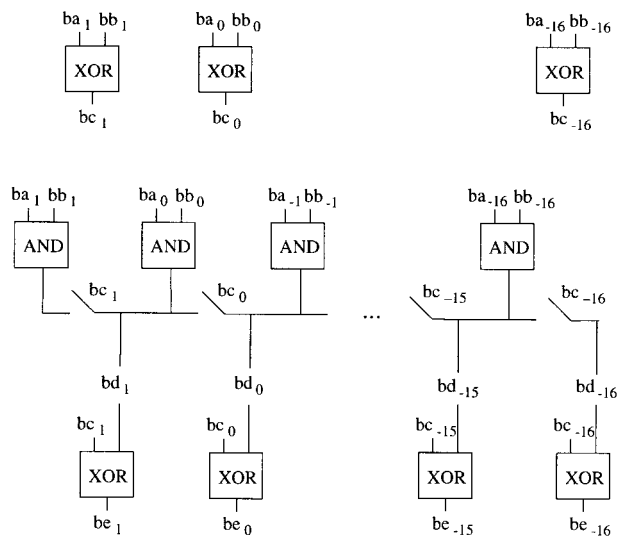

Fig. 7. Circuit for carry look-ahead.

Numerical Algorithms

In this section, I describe the floating-point algorithms the Z3 uses. They are, without exception, the same as those normally used in small sequential floating-point processors.⁶

Floating-Point Exceptions

The problem with floating-point notation is that special conventions have to be used to deal with the number zero. The Z3 solves this problem and deals with other exceptions (overflow and underflow) by monitoring the value of the exponent after any arithmetical operation or a load from memory. A special circuit looks at the state of the bus Ae and captures exceptions. Any number with exponent -64 is flagged as zero: A relay denoted Nn_1 is set

to one if the number is stored in the register pair <Af,Bf>. If the number is stored in the register pair <Ab,Bb>, the relay Nn_2 is set to one. In this way, we always know if one or both of the arguments for an arithmetical operation are zero. Something similar is done for any exponent of value 63 (an infinite number, according to the convention). In this case, the relays Ni_1 or Ni_2 are set to one, according to the register pair in which the number is stored.

Operations involving "exceptional" numbers (zero or infinity) are performed as usual, but the result is overridden by the snooping circuit. Assume, for example, that a multiplication is computed and that the first argument is zero (Nn_1 is set to one). The computation proceeds as usual, but in each cycle the snooping circuit produces the result -64 at the output of the adder of Part A. It does not matter what operations are performed with the significands because the exponent of the result is set to -64, and therefore the final result is zero. Division by an infinite number can be handled in a similar manner. The Z3 can detect undefined operations such as $0/0$, $\infty - \infty$, ∞/∞ , and $0 \times \infty$. In all these cases, the corresponding exception lamp lights on the output panel, and the machine is stopped. The Z3 always produces the correct result when one of the arguments is zero or ∞ and the other is a number within bounds. This was not the case for the Z1. Zuse thought of, but did not implement, exception handling in the Z1. The machine could not correctly perform some computations involving zero.¹⁶

An additional circuit looks at the exponent of the result at the output of the exponent's adder. If the exponent is greater than or equal to 63, overflow has occurred and the result must be set to ∞ . If the exponent is lower than -64, underflow has occurred and the result must be set to zero. To do this, the appropriate relay (Nn_1 or Ni_1) is set to one.

Zuse managed to implement exception handling using just a few relays. This feature of the Z3 is one of the most elegant in the whole design. Many of the early microprocessors of the 1970s did not include exception handling and left it to the software. Zuse's approach is sounder, since it frees programmers from the tedium of checking the bounds of their numbers before each operation.

Addition and Subtraction

In order to add or subtract two floating-point numbers x and y , their representation must be reduced to the same exponent. After this has been done, only the significands have to be added or subtracted. If the exponents are different, the significand of the smaller number is shifted to the right as many places as necessary (and its exponent is incremented correspondingly to keep the number unchanged) until both exponents are equal. It can, of course, happen that the smaller number becomes zero after 17 shifts to the right.

The signs of the two numbers are compared before deciding on the type of operation to be executed. If an addition has been requested and the signs are the same, the addition is performed. If the signs are different, a subtraction is executed. If a subtraction has been requested and the signs are different, an addition is executed. If the signs are the same, the subtraction is executed. A special circuit sets the sign of the final result according to the signs of the arguments and the sign of the partial result.

Addition and subtraction are controlled by a chain of relays (not by a control wheel), since the maximum number of cycles needed is low. Fig. 8 shows the synchronization required for the addition of two numbers. Initially, the arguments for the addition

are stored in the register pairs <Af,Bf> and <Ab,Bb>. In the first cycle, the exponents are subtracted. In Cycle 2, the significand with the larger exponent is loaded into register Ba, and the significand with the smaller exponent is loaded into register Bb. The significand in register Bb is shifted as many places to the right as the absolute value of the difference of the exponents (exception handling takes care of the case in which the smaller number becomes zero after the shift). In Stages I, II, and III of Cycle 2, the significands are added, and finally the processor tests if the result is greater than two. If this is the case, the significand is shifted one position to the right and the exponent is incremented by one. Note that the test "if ($Be \geq 2$)" in Part A of the arithmetical unit is done *after* Be has already been computed in Part B during Stages I, II, and III of Cycle 2.

Zuse managed to implement exception handling using just a few relays. This feature of the Z3 is one of the most elegant in the whole design.

In the case of a subtraction, four or five cycles are needed. Fig. 9 shows the synchronization required for a subtraction. The first two cycles are almost identical to the first two cycles of the addition algorithm, but now the significands are subtracted. Cycle 3 is executed only when the difference of the significands is negative. The effect of Cycle 3 is just to make the significand of the result positive. Cycle 4 is very important: The difference of two normalized significands can have many zeros in the first bit positions to the left. The result is normalized by shifting Be to the left as many places as necessary (this is done with the shifter between the relay box Fd and register Bb). The number of one-bit shifts is subtracted from the exponent in Part A of the processor. In Cycle 5, the result is stored in the register pair <Af,Bf>.

cycle	stage	exponent	significand
0	I,II,III		
1	IV,V	$Aa:=Af$	
	I,II,III	$Ae:=Aa-Ab$	$Be:=0+Bb$
2	IV,V	if ($Ae \geq 0$) then $Ab:=0$, $Aa:=Af$ else $Aa:=0$	if ($Ae \geq 0$) then $Ba:=Bf$, $Bb:=Be$ (shifted) else $Ba:=Be$, $Bb:=Bf$ (shifted) (Be or Bf are shifted $ Ae $ places to the right)
	I,II,III	if ($Be \geq 2$) then $Ae:=Aa+Ab+1$ else $Ae:=Aa+Ab$	$Be:=Ba+Bb$
3	IV,V	$Af:=Ae$	if ($Be \geq 2$) then $Bf:=Be/2$ else $Bf:=Be$

Fig. 8. The three cycles needed for the addition algorithm. The arguments for the addition are stored in the register pairs <Af,Bf> and <Ab,Bb> before the operation is started.

Multiplication

The multiplication algorithm of the Z3 is like the one used for decimal multiplication by hand, that is, it is based on repeated additions of the multiplicator according to the individual digits of the multiplicand. At the beginning of the algorithm, the first argument is stored in the register pair <Af,Bf>. The second argument is stored in the register pair <Ab,Bb>. The temporary regis-

Konrad Zuse's Legacy

ter pair $\langle Aa, Ba \rangle$ is set to zeroes. Fig. 10 shows the microsequencing produced by the multiplication wheel of the control unit. The algorithm takes 16 cycles to run. Note that only the bits of the multiplicand from position -14 to position zero are used. The exponents are added in the first cycle and the result just loops afterward in Part A of the arithmetical unit. The significands are handled in Part B of the unit. Register Ba contains the partial result of the computation. The basic multiplication loop has the following form:

$$\begin{aligned} Ba &:= Be / 2 \\ Be &:= Ba + Bb \times (i\text{th bit of } Bf) \end{aligned}$$

for $i = -14, \dots, 0$. The partial result Be is shifted one position to the right to produce $Ba := Be/2$. This is done with the shifter connected to the relay box Fc.

cycle	stage	exponent	significand
0	I,II,III		
1	IV,V	Aa:=Af	
	I,II,III	Ae:=Aa-Ab	Be:=0+Bb
2	IV,V	if (Ae>0) then Ab:=0, Aa:=Af else Aa:=0	if (Ae>0) then Ba:=Af, Bb:=Be (shifted) else Ba:=Be, Bb:=Bf (shifted) (Be or Bf are shifted Ae places to the right)
	I,II,III	Ae:=Aa+Ab	Be:=Ba-Bb
3	IV,V	Aa:=Ae, Ab:=0	Ba:=0, Bb:=Be
	I,II,III	Ae:=Aa+Ab	Be:=Ba-Bb
4	IV,V	Aa:=Ae Ab:= number of shift positions	Bb:=Be (shifted) (Be is normalized by shifting to the left)
	I,II,III	Ae:=Aa-Ab	Be:=0+Bb
5	IV,V	Af:=Ae	Bf:=Be

Fig. 9. The four-five cycles needed for the subtraction algorithm. The first argument is stored in the register pair $\langle Af, Bf \rangle$ and the second in $\langle Ab, Bb \rangle$ before the operation is started.

The result of the multiplication is a number $1 \leq r < 4$ (for arguments within bounds). In the last cycle, there is a check to see if $r \geq 2$. If this is the case, the result is shifted one position to the right and a one is added to the exponent of the result.

Division

The division algorithm is similar to the multiplication algorithm, but subtraction is used repetitively instead of addition. At the beginning of the algorithm, the dividend is stored in the register pair $\langle Af, Bf \rangle$. The divisor is stored in the register pair $\langle Ab, Bb \rangle$. The temporary register pair $\langle Aa, Ba \rangle$ is set to zeroes. Fig. 11 shows the microsequencing produced by the division wheel of the control unit. The algorithm takes 18 cycles to run.

The main idea of the algorithm is very simple. The exponent of the result is obtained by subtracting the exponents of dividend and divisor. Now for the significand: Assume that we want to compute x/y for the significands x and y . Since we are dealing with normalized numbers, the first digit of the result is one if $x \geq y$ and zero if $x < y$. In the first case, we set the first digit of the result to

one and compute the remainder, which is $x - y$. The remainder is divided recursively by y . To do this, it is shifted one position to the left, and the new result bit is stored at position $[-1]$ of register Bf (in this way nullifying the effect of the shift). If the result bit is zero, the remainder is just x , and the recursive division is continued as in the first case.

cycle	stage	exponent	significand
0	I,II,III		
1	IV,V	Aa:=Af	
	I,II,III	Ae:=Aa+Ab	if (Bf[-14]=1) then Be:=Ba+Bb else Be:=Ba
2	IV,V	Aa:=Ae, Af:=0, Ab:=0	Ba:=Be/2
	I,II,III	Ae:=Aa+Ab	if (Bf[-13]=1) then Be:=Ba+Bb else Be:=Ba
3	IV,V	Aa:=Ae	Ba:=Be/2
	I,II,III	Ae:=Aa+Ab	if (Bf[-12]=1) then Be:=Ba+Bb else Be:=Ba
⋮	⋮	⋮	⋮
i	IV,V	Aa:=Ae	Ba:=Be/2
	I,II,III	Ae:=Aa+Ab	if (Bf[i - 15]=1) then Be:=Ba+Bb else Be:=Ba
⋮	⋮	⋮	⋮
15	IV,V	Aa:=Ae	Ba:=Be/2
	I,II,III	if (Be ≥ 2) then Ae:=Aa+1	If (Bf[0]=1) then Be:=Ba+Bb else Be:=Ba
16	IV,V	Af:=Ae	if (Be ≥ 2) then Bf:=Be/2 else Bf:=Be Bb:=0

Fig. 10. The 16 cycles needed for the multiplication algorithm. The i th bit of register Bf is denoted by $Bf[i]$. The first argument is stored in the register pair $\langle Af, Bf \rangle$ and the second in $\langle Ab, Bb \rangle$ before the operation is started.

The basic division loop has the following form:

$$\begin{aligned} Ba &:= 2 \times Be \\ \text{if } (Ba - Bb \geq 0) &\text{ then } Be := Ba - Bb, Bf[i] := 1 \\ &\text{else } Be := Ba \quad Bf[i] := 0 \end{aligned}$$

for $i = 0, \dots, -14$. The partial result Be is shifted one position to the left to produce $Ba := 2 \times Be$. This is done with the shifter connected to the relay box Fc.

The result of the division of significands is a number $\frac{1}{2} < r < 2$. This condition is tested in Cycles 17 and 18. If $r < 1$, a one is subtracted from the exponent, and the result is shifted one position to the left in order to get a normalized number.

Square Root Extraction

The square root algorithm is the jewel in the crown of the Z3. Fig. 12 shows the microsequencing required during the 20 cycles

needed to compute the square root of a number. The argument for the operation is stored in the register pair <Af,Bf>. The register pair <Aa,Ba> is initialized to zeroes. The algorithm computes the square root of numbers with an even exponent. If the exponent is an odd number, the significand is shifted one place to the left, and the exponent is decremented by one. The final exponent (computed in Cycle 19) is half this initial exponent.

cycle	stage	exponent	significand
0	I,II,III		
1	IV,V	Aa:=Af	Ba:=Bf
	I,II,III	Ae:=Aa-Ab	if (Ba-Bb ≥ 0) then Be:=Ba-Bb, bt:=1 else Be:=Ba, bt:=0
2	IV,V	Aa:=Ae Ab:=0	Bf:=0 if (bt=1) then Bf[0]:=1 Ba:=2×Be
	I,II,III	Ae:=Aa+Ab	if (Ba-Bb ≥ 0) then Be:=Ba-Bb, bt:=1 else Be:=Ba, bt:=0
3	IV,V	Aa:=Ae	if (bt=1) then Bf[-1]:=1 Ba:=2×Be
	I,II,III	Ae:=Aa+Ab	if (Ba-Bb ≥ 0) then Be:=Ba-Bb, bt:=1 else Be:=Ba, bt:=0
⋮	⋮	⋮	⋮
i	IV,V	Aa:=Ae	if (bt=1) then Bf[2-i]:=1 Ba:=2×Be
	I,II,III	Ae:=Aa+Ab	if (Ba-Bb ≥ 0) then Be:=Ba-Bb, bt:=1 else Be:=Ba, bt:=0
⋮	⋮	⋮	⋮
16	IV,V	Aa:=Ae	if (bt=1) then Bf[-14]:=1 Ba:=2×Be
	I,II,III	Ae:=Aa+Ab	if (Ba-Bb ≥ 0) then Be:=Ba-Bb, bt:=1 else Be:=Ba, bt:=0
17	IV,V	if (Bf[0] = 0) then Ab:=-1	Ba:=Bf, Bb:=0
	I,II,III	Ae:=Aa+Ab	Be:=Ba+Bb
18	IV,V	Af:=Ae	if (Bf[0]=0) then Bf:=2×Be else Bf:=Be

Fig. 11. The 18 cycles needed for the division algorithm. The *i*th bit of register Bf is denoted by Bf[i]. The dividend is stored in the register pair <Af,Bf> and the divisor in <Ab,Bb> before the operation is started.

The main idea of the classical algorithm is to reduce the square root operation to a division. If we want to compute the square root of x , we need a number Q such that $x/Q = Q$. The result Q is built sequentially by setting the *i*th bit to one and then testing whether the condition $x > Q^2$ still holds. If this is not the case, the *i*th bit must be set to zero.

Assume that we have already computed from bit zero to bit $-i + 1$ of the final result. Denote by Q_{-i+1} the significand

$$Q_{-i+1} = Bf[0] \times 2^0 + Bf[-1] \times 2^{-1} + \dots + Bf[-i+1] \times 2^{-i+1}.$$

Bit $-i$ is then set to q_{-i} and it must hold that

$$x \geq Q_{-i}^2 = (Q_{-i+1} + q_{-i} 2^{-i})^2$$

This is true if

$$x - Q_{-i}^2 = (x - Q_{-i+1}^2) - 2^{-i} q_{-i} (2Q_{-i+1} + 2^{-i} q_{-i}) \geq 0$$

Define t_{-i} using the expression

$$2^{-i} t_{-i} = x - Q_{-i}^2 = (x - Q_{-i+1}^2) - 2^{-i} q_{-i} (2Q_{-i+1} + 2^{-i} q_{-i})$$

This can be written as

$$2^{-i} t_{-i} = t_{-i+1} 2^{-i+1} - 2^{-i} q_{-i} (2Q_{-i+1} + 2^{-i} q_{-i})$$

where we have used the recursive definition

$$2^{-i+1} t_{-i+1} = (x - Q_{-i+1}^2).$$

Simplifying the last expression, we finally get:

$$t_{-i} = 2t_{-i+1} - q_{-i}(2Q_{-i+1} + 2^{-i} q_{-i})$$

If t_{-i} is positive for $q_{-i} = 1$, we set bit $-i$ of the final result to one, i.e., $Bf[-i]:=1$. If t_{-i} is negative, we set $Bf[-i]:=0$. The recursive computation is started with $t_0 = x$. Q_{-i+1} represents at each step the partial result contained in register Bf. Bit $-i$ is tentatively set to one, and the sign of t_{-i} is tested. The basic loop of the square root algorithm for bit $-i$ has the following form:

```

Ba := 2 × Be
Bb := 2 × Bf
Bb[-i] := 1
if (Ba - Bb ≥ 0) then Be := Ba - Bb, Bf[-i] := 1
else Be := Ba, Bf[-i] := 0

```

The square root algorithm is the jewel in the crown of the Z3.

All bits of register Bf are used for the computation of the square root. If the original number lies within bounds, the result is also within bounds.

Read and Display Instructions

The two most complex instructions of the Z3 are those related to the input and output of decimal numbers. A decimal number of four digits entered through the keyboard is first converted into a binary integer. This is done by reading each digit sequentially, transforming it into a binary number, and storing it in the bits Ba[-10], Ba[-11], Ba[-12], and Ba[-13] of register Ba. The number in register Ba is multiplied by 10, and the procedure is repeated for the other digits. After four iterations, the decimal input has been transformed to a binary number (the exponent of the binary representation is formed indirectly via shifts resulting from multiplication by 10). The difficult part is handling the exponent. If the exponent e is positive, the significand has to be multiplied e times with 10. If it is negative, it must be multiplied $|e|$ times with 0.1. Multiplying with 10 is relatively easy: The significand in Be can be shifted one bit to the left and then stored in Ba (i.e., $Ba := 2 \times Be$). At the same time, Be can be shifted three places to the left and can be stored in Bb (i.e., $Bb := 8 \times Be$). The addition of Ba and Bb then provides the desired result: the multiplication

Konrad Zuse's Legacy

of the original number in B_e with the constant 10. The process takes four cycles for each multiplication, that is, 32 cycles for the decimal exponent +8. Since a read operation needs a minimum of nine cycles, this means that a decimal number with exponent +8 is read in 41 cycles.

cycle	stage	exponent	significand
0	I,II,III		
1	IV,V		If $(A_f[0]=1)$ then $B_a:=2 \times B_f$ else $B_a:=B_f$ $B_b[0]:=1$
	I,II,III		if $(B_a - B_b \geq 0)$ then $B_e:=B_a - B_b$, $bt:=1$ else $B_e:=B_a$, $bt:=0$
2	IV,V		$B_f:=0$ // if $(bt=1)$ then $B_f[0]:=1$ $B_a:=2 \times B_e$, $B_b:=2 \times B_f$, $B_b[-1]:=1$
	I,II,III		if $(B_a - B_b \geq 0)$ then $B_e:=B_a - B_b$, $bt:=1$ else $B_e:=B_a$, $bt:=0$
3	IV,V		if $(bt=1)$ then $B_f[-1]:=1$ $B_a:=2 \times B_e$, $B_b:=2 \times B_f$, $B_b[-2]:=1$
	I,II,III		if $(B_a - B_b \geq 0)$ then $B_e:=B_a - B_b$, $bt:=1$ else $B_e:=B_a$, $bt:=0$
⋮	⋮	⋮	⋮
i	IV,V		if $(bt=1)$ then $B_f[2-i]:=1$ $B_a:=2 \times B_e$, $B_b:=2 \times B_f$, $B_b[1-i]:=1$
	I,II,III		if $(B_a - B_b \geq 0)$ then $B_e:=B_a - B_b$, $bt:=1$ else $B_e:=B_a$, $bt:=0$
⋮	⋮	⋮	⋮
18	IV,V		if $(bt=1)$ then $B_f[-16]:=1$ $B_a:=2 \times B_e$, $B_b:=2 \times B_f$
	I,II,III		if $(B_a - B_b \geq 0)$ then $B_e:=B_a - B_b$, $bt:=1$ else $B_e:=B_a$, $bt:=0$
19	IV,V	$A_a:=A_f/2$	$B_a:=B_f$, $B_b:=0$
	I,II,III	$A_e:=A_a+0$	$B_e:=B_a+B_b$
20	IV,V	$A_f:=A_e$	$B_f:=B_e$

Fig. 12. The 20 cycles needed for the square root algorithm. The i th bit of registers B_f and A_f are denoted by $B_f[i]$ and $A_f[i]$, respectively. The argument is stored in the register pair $\langle A_f, B_f \rangle$ before the operation is started.

In the case of negative exponents, multiplication with the constant 0.1 is performed using the shifters and the adders as well. This multiplication is somewhat more complex, because 0.1 is a periodic number in the binary system. The description of the microsequencing used would take us too far away from the main topics, so I omit it here. (It can be found in Zuse's patent application.¹⁴)

The display instruction works by multiplying or dividing iteratively by 10. If the binary exponent of the number in register R1 is

positive, the number is multiplied with 0.1 as many times as needed to make the binary exponent equal to two and until the first left four bits of register B_f contain a number between zero and nine (0000 and 1001). This is the decimal digit that can be displayed in the next column of the output panel. The number is subtracted from the significand in B_f , and the process continues for the following digits. If the binary exponent of the number in register R1 is negative, the process is similar, but multiplications with the constant 10 are used.

Complete Architecture of the Z3

I will now explain the detailed diagram of the Z3 shown in Fig. 13.

I discussed the control unit and the I/O panels earlier. Notice that the four decimal digits of the input keyboard are transferred to register B_a using the relay boxes Z_a , Z_b , Z_c , and Z_d , which are activated one after the other.

The relay boxes E_g and E_i are used to set some useful constants directly into the exponent registers (+13 and -4, which are used for the numerical base conversions). The shifter E_e between register A_f and register A_a is used for the square root algorithm. The exponent of the result (A_a) becomes half the exponent (A_f) of the original number.

A_h_1 is a relay acting as a flip-flop. When it is set to zero, the register pair $\langle A_f, B_f \rangle$ is accessed by load operations. When it is set to one, the register pair $\langle A_b, B_b \rangle$ is accessed. This relay is reset to zero by the control line a_i . The control lines a_i , a_j , b_i , and b_j are used to clear the registers A_f , A_b , B_f , and B_b when needed.

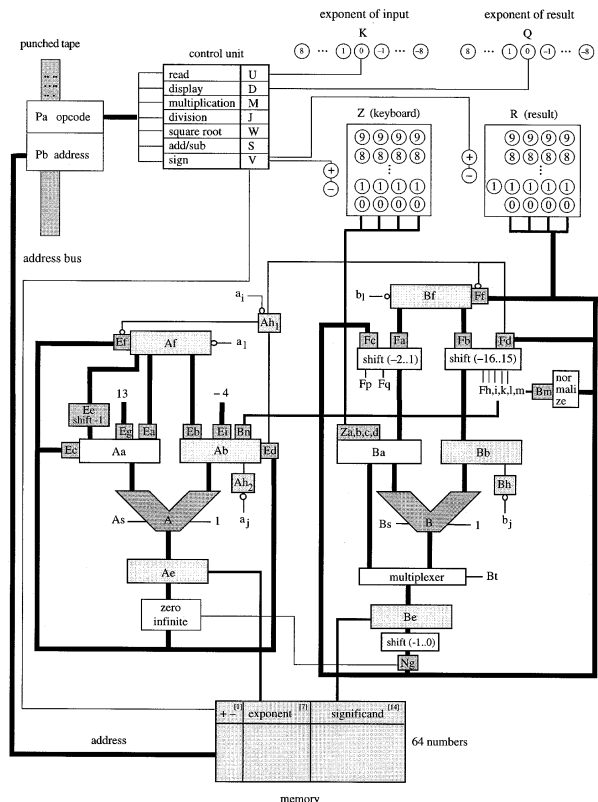

Fig. 13. The complete architecture of the Z3.

The box labeled “zero, infinite” below Ae represents the circuits for exception handling. They snoop permanently on the data bus (results of operations and data from memory) and raise the corresponding exception flags when needed. The shifter below Be is used to displace the significand one bit to the right. This provides the normalization needed for the significand whenever $Be \geq 2$.

Fp and Fq are the relays that control the number and direction of one-bit shifts in the shifter below the relay boxes Fc and Fa. Fh, Fi, Fk, Fl, and Fm have the same function in relation to the other shifter. Using these five bits, the numbers between -16 and 15 can be represented, and this is also the range of the second shifter. When such a shift is performed, the number represented by the relays Fh to Fm is transferred through the relay box Bn to register Ab in order to modify the exponent of the result. If the number is shifted 10 positions to the left, then $+10$ is subtracted from the exponent of the result. Such drastic shifts are needed mostly after subtractions.

Look again at the diagram of the Z3. Everything makes sense now and looks as conventional as any modern small floating-point processor. It is indeed amazing how Zuse was able to find the adequate architecture right from the beginning. The Z3 processor employs just 600 relays; the memory needs three times as much. By having to optimize the design and by having to save hardware everywhere, Zuse was *forced* to think and rethink the logical structure of his machine. He was not allowed the luxury of the almost unlimited funding allocated by the U.S. military for the development of the ENIAC or by IBM for the Mark I. He was all alone. While this may have worked to his advantage from the conceptual side, it may also have worked to his disadvantage, considering the negligible impact that the Z1 and Z3 had on the emerging U.S. computer industry after World War II.¹³

The Invention of the Computer

The main defect of the Z3 was the absence of a conditional branch in the instruction set. When the program is stored on punched tape, a possible fix is to include multiple tapes and a mechanism to switch between them (as was done with the Harvard Mark I). Another possibility is having a “program counter,” so that the tape can be advanced or rewound on demand.

Sometimes the dividing line between calculating machines and universal computers is drawn by differentiating between machines with externally or internally stored programs. I have argued elsewhere¹⁰ that this is not a valid criterion. An external program can work as an interpreter of numerical data. The external program becomes a fixed part of the processor, and the data become the program, much in the same way as a universal Turing machine works as an interpreter. I have argued that what is needed for universal computation is a minimal instruction set and indirect addressing.¹¹ Indirect addressing can be simulated by writing self-modifying programs, so that the instruction set becomes the defining criterion. A machine with enough addressable memory and an accumulator and that is capable of executing the instructions CLR (clear), INC (increment), LOAD, STORE, and BZ (branch if zero) is a universal computer. In this sense, the Z1 was *not* a fully fledged computer, but neither were any of the other early machines. The ABC was a special-purpose machine for solving sets of linear equations by Gaussian elimination; the Harvard Mark I lacked conditional

branching, although it featured loops; the ENIAC was not even programmable through software—the building blocks had to be hardwired in dataflow fashion. Conditional branching was available in the ENIAC only in a limited way, and self-modifying programs were, of course, out of the question.

TABLE 2
COMPARISON OF ARCHITECTURAL FEATURES

Machine	memory and CPU separated?	conditional branching?	soft or hard programming	self-modifying programs?	indirect addressing?
Zuse's Z1	✓	×	soft	×	×
Atanasoff's	✓	×	hard	×	×
H-Mark I	×	×	soft	×	×
ENIAC	×	partially	hard	×	×
M-Mark I	✓	✓	soft	✓	×

TABLE 3
SOME ADDITIONAL ARCHITECTURAL FEATURES

Machine	internal coding	fixed-point or floating-point?	bit-sequential arithmetic?	architecture	technology
Zuse's Z1	binary	floating	no	sequential	mechanical
Atanasoff's	binary	fixed-point	yes	vectorized	electronic
H-Mark I	decimal	fixed-point	no	parallel	electromechanical
ENIAC	decimal	fixed-point	no	dataflow	electronic
M-Mark I	binary	fixed-point	yes	sequential	electronic

Tables 2 and 3 show the most relevant information about the early computing machines mentioned earlier. As should be clear from the tables, none of the early computing machines fulfills all the necessary requirements for a universal computer. I also include the Mark I machine built in Manchester from 1946 to 1948, because as far as I know this was the first machine to fit my definition of a universal computer. The Mark I was built under the direction of F.C. Williams and T. Kilburn. This machine stored its program in random-access digital memory implemented with CRT tubes. All necessary instruction primitives were available (in modified form), and although it lacked indirect addressing, self-modifying programs could be written. The first program ran in June 1948 and calculated the highest proper factor of a large number.⁷ In September 1948, Turing was appointed as a reader in mathematics in Manchester and wrote some programs for the first universal computer in the world. His vision of universal computation published in 1936, the same year in which the storage unit of the Z1 was completed, had at last become a reality. Tables 2 and 3 are emphatic: The invention of the computer was a collective achievement encompassing two continents and 12 years.

Acknowledgments

Deciphering the sketchy documentation available was possible only with the collaboration of several of my students at the Universities of Halle and Berlin. I thank Alexander Thurm and Axel Bauer, who implemented a gate-level simulation of the Z3 processor. We became aware of synchronization problems when the simulation refused to run. I also thank Franz Konieczny, Reimund Spitzer, and Roland Schultes, who wrote part of a stand-alone simulation of the processor in C. We started working on the Z3 with the help of Konrad Zuse, who gladly answered our questions. It was amazing to see how, after almost 60 years, the whole design of the Z3 was still in his head. Unfortunately, Zuse died in December 1995 before this description of his work was ready. This paper is dedicated to his memory.

References

- [1] H. Aiken and G. Hopper, "The Automatic Sequence Controlled Calculator," reprinted in B. Randell, ed., *The Origins of Digital Computers*. Berlin: Springer Verlag, 1982, pp. 203-222.
- [2] A.W. Burks and A.R. Burks, "The ENIAC: First General Purpose Electronic Computer," *Annals of the History of Computing*, vol. 3, no. 4, pp. 310-399, 1981.
- [3] A.W. Burks and A.R. Burks, *The First Electronic Computer: The Atanasoff Story*. Ann Arbor: Univ. of Michigan Press, 1988.
- [4] K.-H. Czauderna, *Konrad Zuse, der Weg zu seinem Computer Z3*. Munich: Oldenbourg Verlag, 1979.
- [5] D. Knuth, *The Art of Computer Programming-Seminumerical Algorithms*, vol. 2. Reading, Mass.: Addison Wesley, 1981.
- [6] I. Koren, *Computer Arithmetic Algorithms*. Englewood Cliffs, N.J.: Prentice Hall, 1993.
- [7] S.H. Lavington, *A History of Manchester Computers*. Manchester, England: NCC Publications, 1975.
- [8] S.H. Lavington, *Early British Computers*. Manchester, England: Digital Press, 1980.
- [9] B. Randell, ed., *The Origins of Digital Computers*. Berlin: Springer Verlag, 1982.
- [10] R. Rojas, "Who Invented the Computer? The Debate from the Viewpoint of Computer Architecture," W. Gautschi, ed., *Fifty Years Mathematics of Computation*, Proceedings of Symposia in Applied Mathematics, AMS, pp. 361-366, 1993.
- [11] R. Rojas, "On Basic Concepts of Early Computers in Relation to Contemporary Computer Architectures," *Proc. 13th World Computer Congress*, Hamburg, pp. 324-331, 1994.
- [12] U. Schweier and D. Saupe, "Funktionen und Konstruktionsprinzipien der programmgesteuerten mechanischen Rechenmaschine Z1," *Arbeitspapiere der GMD 321*, Bonn, 1988.
- [13] N. Stern, *From ENIAC to UNIVAC*. Bedford: Digital Press, 1981.
- [14] K. Zuse, *Patentanmeldung Z-2391*, German Patent Office, Berlin, 1941.
- [15] K. Zuse, *Der Computer mein Lebenswerk*. Berlin: Springer-Verlag, 1970.
- [16] K. Zuse, personal communication, Mar. 18, 1995.



Raúl Rojas received his bachelor's degree in mathematics and physics at the National Technical University of Mexico and a master's in mathematics from the same institution. He received the PhD from the Free University of Berlin in 1988. He has been working on neural networks since 1988 and got the German Habilitation title in 1994.

Dr. Rojas was a computer science researcher at the National Laboratory for Mathematics and Computer Science in Berlin from 1986 to 1989. Then he was associate researcher at the Free University of Berlin's Department of Mathematics and Computer Science from 1989 to 1994. Since 1994 he has been a professor of computer science at the University of Halle. Dr. Rojas has published *Neural Networks* (Springer-Verlag, 1996). He has held seminars on the history of computing for computer science students.

The author can be contacted at
Department of Mathematics and Computer Science
Martin Luther University
Kurt Mothes Str. 1
06120 Halle, Germany
e-mail: rojas@inf.fu-berlin.de